

Periodical 52418
**Kansas City
Public Library**

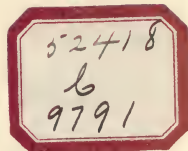

This Volume is for
REFERENCE USE ONLY



PUBLIC LIBRARY
KANSAS CITY
MO

From the collection of the

o PreLinger
v Library
z n m
t p

San Francisco, California
2006

YANAGI JINRO
YUO SAKAI
ON

PUBLIC LIBRARY

KANSAS CITY

MO

YRABALI SILIRIN
YTIC SASMAN
ON

AMATEUR WORK

A MONTHLY MAGAZINE OF THE USEFUL ARTS AND SCIENCES.

CONTAINING
ILLUSTRATED ARTICLES DESCRIPTIVE OF ELECTRICAL AND
MECHANICAL APPARATUS, FURNITURE AND OTHER
USEFUL ARTICLES, GAMES, PHOTOGRAPHY,
PATTERN MAKING, BOAT BUILDING,
ETC., ETC.

VOLUME III.

PUBLISHED BY
DRAPER PUBLISHING COMPANY,
BOSTON, MASSACHUSETTS.
1904.

YRABLI OLBIH
YTIO ZABHAI
OH

ASIOH ALITZ

Bound
Periodical
Children's Room

52418
6
9791

INDEX.

About Patents	307	Elementary Mechanics	102, 138, 166, 196, 225, 255, 281, 309, 333
Acetylene Generator	85	Engine, Hot Air	113
Air Engine, Hot	113	Engine, Model Turbine	184
Arm Chair	158	Engineer, The High Tension	278
Attachments for Lathe	252	Experiments for Beginners, Induction Coil	55
Bagatelle Board	36	Fire Extinguisher, Chemical	324
Balance, A Jolly	43	Flash Lamp, Electrically Operated	64
Balance, A Simple	99	Focussing Cloth	269
Bathroom Cabinet	91	Fruits and Nuts as Food	69
Battery, Storage	216	Furniture	
Bedstead, A	183	Spring Box Couch	17
Belts, Lacing Leather	219	Small Table	63
Bench Grinder	202, 306	Bath Room Cabinet	91
Bench Micrometer	15	Boot Blacking Stand	110
Bench Trimmer	296	Plant Stand or Taboret	157
Bicycle Foot Power	322	Arm Chair	158
Boat, 12 Foot Row	246	A Bedstead	183
Boot Blacking Stand	110	A Bureau	229
Bowling Alley, Carrom	35	Chiffonier for Men	286
Box Couch, Spring	17	Galvanometer, Simple	218
Boys Can Earn Money, How	168, 198, 226, 310	Galvanometer, Sensitive	279
Brown Prints instead of Blue	9	Games for Christmas	
Bureau, A	229	Carrom Bowling Alley	35
Cabinet, Bath Room	91	Bagatelle Board	36
Carrom Bowling Alley	35	Gas Engine, Design and Use of	37
Castings in Soft Metals and Alloys	250	Gas Engines Spark Coils	
Chamber Set		For Make and Break Type	29
The Bedstead	183	For Jump Spark Ignition	79
The Bureau	229	Gasolene Car, Design for Light	299, 327
Chiffonier for Men	286	Generator, Acetylene	85
Chair, An Arm	158	Grinder, A Bench	262, 306
Chemically Colored Lantern Slides	89	Grindstone and its Use	73
Chemical Fire Extinguisher	324	Hand Cylinder Printing Press	45
Chiffonier for Men	286	Handy Combination, A	261
Coils, Gas Engine Spark	29, 79	Handy Hints for Amateurs	252, 261, 296, 322
Coils, Modern Ruhmkorff	136	Hand Milling Machine	316
Condenser, Oil Immersed	179	Handy Receipts	
Couch, Spring Box	17	Household Paste	27
Current Reverser for Spark Coil	215	Ink for Rubber Stamps	27
Cutting Tools for Planer or Lathe	4	To Clean Lenses	56
Design for Light Gasolene Car	227, 299	Flemish or Dark Oak Stain	56
Design and Use of Gas Engines	37	Waterproofing Shoes	56
Developer, "Pyro"	224	Cement for Glass or Metal	95
Dory, Power	18, 48	Harness Dressing	95
Dory, Sailing	199	Ammonia Soap	95
Dynamo, An 80 Watt	190	Hand Saws	22, 53, 77
Earn Money, How Boys Can	168, 198, 226, 310	High Frequency Phenomena	243
Electric Alarm for Clock	338	High Tension Engineer	278
Electricity by Experiment	139, 168, 198	Hot Air Engine	113
Electrical Formulas, Two	242	Indicator, Polarity	217
Electric Railway, Model	1, 39	Induction Coil Experiments for Beginners	55
Electrotypes, How to Make	276		

Interrupter, Mercury	181	Printing Frame	253
Interrupter, Rotary	153	Removing Air Bubbles	254
Interrupter, Wehnelt	243	Posing the Hands	254
Joints in Woodworking	237, 271, 337	Printing in Platinum	267, 291
Jolly Balance	43	Removing Films	269
Junior Department		Focussing Cloth	269
Model "Reliance"	25	Railway, Model Electric	1, 39
Marble Coaster	27	Receiver, Wireless Telegraph	150
Induction Coil Experiments for Beginners	55	Recorder, Telegraph	285
Model Steamboat	83	Relay, A Sensitive	151
Elementary Mechanics	102, 138, 166, 196, 225, 309, 335	Reverser for Spark Coil, Current	215
Letter to Young Men	336	Rheostat, A	313
Joints in Woodworking	337	Rotary Interrupter	153
Electric Alarm for Clock	338	Row Boat, 12 Foot	246
Lacing Leather Belts	219	Rowing Skiff	169
Lantern, Magic	57	Sailboat, How to Build A	75, 105, 129, 161, 193, 220
Lantern Slides, Chemically Colored	89	Sailing Dory	199
Lantern Slides from Prints	311	Sailing Rules for Launches	155
Lantern Slide Holder	174	Sailing Rules for Yachts	297
Lantern Slide Making	87, 119, 144, 172, 210, 233	Saw Block	296
Letter to Young Men	336	Saws, Hand	22, 53, 77
Lathe, Attachments for	252	Screw Cabinet, Nail and	322
Lathe, Cutting Tools for Planer or	4	Sensitive Relay	151
Machine Drawing	10, 40, 96	Set of Weights, How to Make	127
Magic Lantern	57	Sharpening Device, Tool	209
Mechanics, Elementary	102, 138, 166, 196, 225, 255, 281, 309, 335	Skiff, A Rowing	169
Mechanic's Note Book	101	Soldering	249, 275
Mercury Interrupter	181	Soft Metals and Alloys, Casting in	250
Microscopy for Amateurs	12, 31, 61, 92, 116	Spark Coil, Current Reverser for	215
Micrometer, A Bench	15	Spark Coil, Gas Engine	29, 79
Milling Machine, Hand	316	Spring Box Couch	17
Model Electric Railway	1, 39	Steamboat, Model	83, 111, 135, 149, 165
Model "Reliance"	25	Steam Turbine, Model	65
Model Steamboat	83, 111, 135, 149, 165	Still for Water	152
Model Steam Turbine	65	Spectroscope, A	141
Model Turbine Engine	184	Table, A Small	63
Modern Ruhmkorff Coils	136	Taboret, A Plant Stand or	157
Mounting Prints, Judgment in	34	Telegraph Apparatus, Wireless	258
Nail and Screw Cabinet	322	Telegraph Recorder	285
Note Book, Mechanic's	101	Telegraph Transmitter	257
Notes on Wireless Telegraphy	323	Telephone Circuits and Wiring	213, 240, 260, 294, 318
Oil Immersed Condenser	179	Thermit, The New Compound	109
Pattern Making for Amateurs	122, 146, 176, 204, 231, 264, 287, 319	Tools and their Uses	111
Patents, About	307	Tool Making for Amateurs	272, 304, 331
Planer or Lathe, Cutting Tools for	4	Tool Sharpening Device	209
Plant Stand or Taboret	157	Transformers and Choking Coils	71
Polarity Indicator	217	Transmitter, Telegraph	257
Power Dory	18, 48	Turbine Engine, Model	184
Printing for Beginners	21, 51, 80, 107, 133, 160, 195	Turbine, Model Steam	65
Printing Press, Hand Cylinder	45	Twist Drills, Their Uses and Their Abuses	333
Photography		Varnish Making	227
Brown Prints Instead of Blue	9	Water, A Still for	152
Judgment in Mounting Prints	34	Wehnelt Interrupter	243
Electrically Operated Flash Lamp	64	Weights, How to Make a Set of	127
"Pyro" Developer	224	Wireless Telegraph Apparatus	258
		Wireless Telegraph Receiver	156
		Wireless Telegraphy Plant	223
		Woodworking, Joints in	237, 271, 337

AMATEUR WORK

A MONTHLY MAGAZINE OF THE USEFUL ARTS AND SCIENCES

Vol. III. No. 1.

BOSTON, NOVEMBER, 1903.

Ten Cents a Copy.

A MODEL ELECTRIC RAILWAY.

ROBERT GIBSON GRISWOLD.

III. THE TRACK.

For the successful operation of a model railroad, it is essential that the track should be especially well designed and built. A model seldom has the proportionate weight to keep it to the rails, and any slight inequality in the rail may tend to lift the wheel off the tread. Much, of course, depends on the finish of the wheel flange and tread.

In the construction of frogs and switches, care must be taken to have the points and joints well smoothed off, and the relative parts securely fastened together. As far as possible, in keeping with simple amateur construction, the track equipment will follow closely the designs in use on the standard railroads.

In Fig. 1 is shown a section of double track including two split switches and two single frogs. Since this is designed as a "third rail" system, it is necessary that the *third rail* should be mounted on either side of the track just outside the rail. This system, while requiring about double the quantity of third rail, is far better than the single rail especially where switches and frogs occur. If the car is moving slowly over these places the current may be entirely shut off the motor and it will come to a standstill.

Another method is to provide the car with two sliding shoes, one on either side which will materially reduce the resistance of the system. When two shoes are provided, the double third rail may be omitted except at switches and frogs.

When the car passes these points one of the shoes will be in contact with a rail at all times and no break in the current will ensue. This is perhaps the most satisfactory arrangement. It will then make no difference in what direction the car travels, as a shoe is carried on either side of the car.

At *a*, Fig. 1, is shown the end elevation of the rails and a tie. The gauge of the rails is $2\frac{1}{2}$ " and the third rails are set $\frac{1}{2}$ " outside the rail-head. The rail used in this system is a special form made of rolled strip brass which may be obtained in six-foot lengths, is straight and true to size and the head is nicely formed. It can be fastened to the ties by small *gimp* tacks which have a button head, setting nicely over the flange of the rail. The third rail is merely a strip of brass bent into the shape of an L and secured to the ties in the same manner. If preferred, strips of metal may be substituted for the wooden ties and the rails soldered thereto. The ties are four inches long, by one half an inch wide, and one quarter of an inch thick.

The rails above mentioned can readily be joined together by means of a stud driven into the head of one of the abutting sections, the rail-head being hollow. File up such a stud from brass wire and fasten one into each rail with a little solder, leaving the other end hollow. Sections thus provided will match exactly and form good electrical contact. The third rails may be joined by soldering

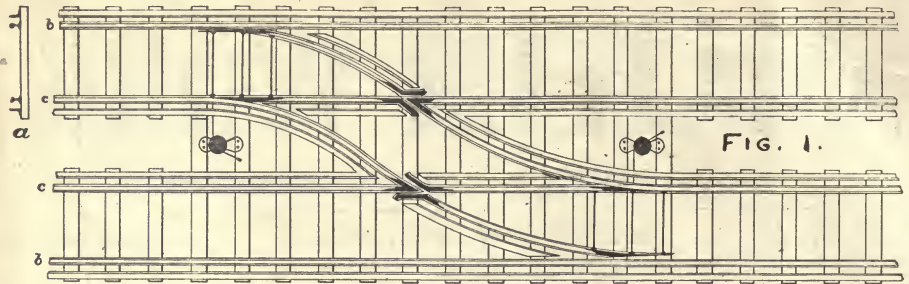

FIG. 1.

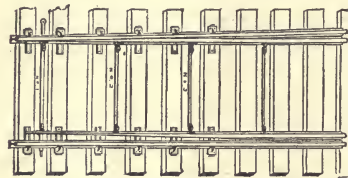

FIG. 2.

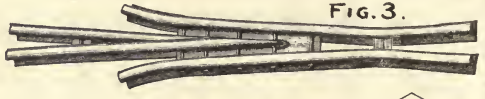

FIG. 3.

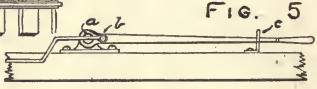

FIG. 5.

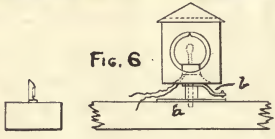

FIG. 6.

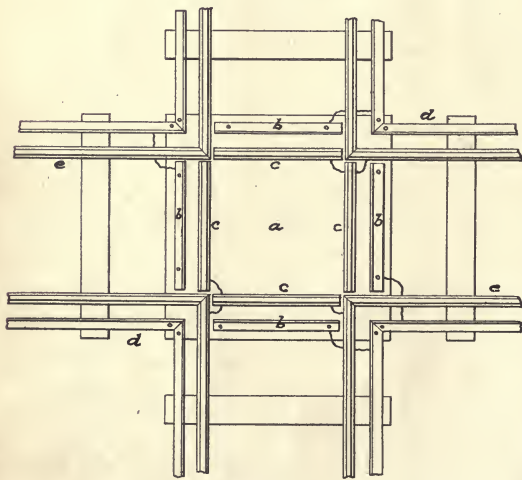

FIG. 4.

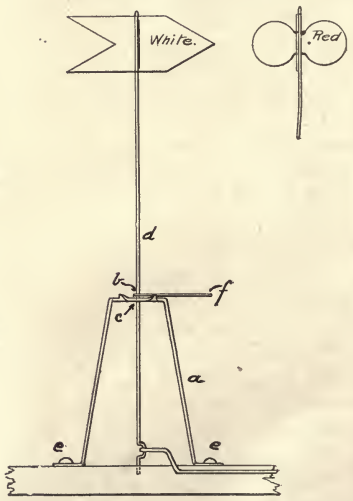

FIG. 7.

to each side of one end, a small strip of brass thus forming a slot into which the abutting rail may fit and secure good electrical contact.

In making curved sections the rails should be annealed by heating to a dull red and plunging into water, (the ralling having rendered the brass very hard) lay out the curve desired on a $\frac{1}{2}$ "

board and carefully bend the rail to fit. Do not allow the flanges to double up while bending, as they have a tendency to do, but keep them flat by hammering, as the bending proceeds. The inside rail, of course, has a lesser radius than the outside, and the board may be cut to its arc after the outer rail is finished. Make the ap-

proach to each curve very gradual so that the cars will take it easily.

In Fig. 2 is shown a knife switch drawn to a slightly larger scale than Fig. 1, showing the details more clearly. The rails are not cut for this form of switch as in the *stub* switch. The outside rail *b*, is curved straight while the inside rail is curved to form the end of the switch, and terminates in a point at the frog in the inside rail of the adjoining track. Take a piece of rail and file the end down to a long thin point and raise the flange so that it will clear the flange of the rail against which it lays. There should be no abrupt change at this point but the tapered end should lead away from the rail very gradually for at least a distance equal to the gouge. Make two such pieces for each switch and bend one to the curve of the turnout as shown in Fig. 1. These tapered rails are connected together by tie-rods shown numbered in the figure as Nos. 1, 2, 3, and 4. These tie rods may be pieces of wire soldered to the rail flange and are provided to keep the rails the correct distance apart and move them simultaneously. The rails are fastened to the ties directly beyond the last tie-rod and the further away from the point that the first fastening occurs, the more flexible will the switch be. One of the tie-rods, generally No. 1, is extended to one side for attachment to a ground lever for throwing the switch. In this case the wire may be bent down slightly to allow it to pass beneath the rail.

The frog will present the greatest difficulty in construction. The joints must be made smooth and nicely tapered. Fig. 2 is an illustration of a standard frog which shows the details of construction very clearly. Instead of placing a block between the tracks as here shown, solder the various pieces to a brass plate which will make a very solid and substantial frog. Lay the frog down on paper first so as to more readily measure the tapers required and then cut the rail to fit as designed. In all frogs the gap is so proportioned that when the wheel is passing over it the tread will rest on the rail beyond before it leaves the point, thus relieving this point of the great weight which would soon smash it. Do not allow more space for the flange between the tracks than necessary. In the practical use of

frogs on railroads, a guard rail is provided, lying close to the outer rail but on the inside, allowing just sufficient space between the two heads for the flange to pass. The purpose of this extra rail is to prevent the wheel slipping to one side further than it should, and climbing upon the point of the frog which would, of course derail the train.

The third rail should be about $\frac{1}{32}$ " higher than the track-rail, so that the shoe will not cause a short circuit as it passes over the breaks. If care is taken in fitting these third rail sections, very small gaps can be secured and the sliding-shoe will pass over them freely in either direction. Wherever a break in this rail occurs, as at points where it crosses the track-rail and comes close to the frog, taper the ends towards the flange so that the shoe may not catch. Connect the various sections of third rail together by soldering wires thereto, so that no section will be "dead" when the car passes over it. It is also a good plan to connect the track rails together by soldering a wire between, at least one in each section. This will be found to materially reduce the resistance of the circuit, especially if one of the rail connections should be faulty.

In Fig. 4 is shown a cross-over together with the third rail and connections. The middle block *a*, is best made of one piece, and in the event of the crossover being made in a separate section, the piece *a* had better be extended to the position occupied by the ties shown. This method of construction will give support to the rails and prevent distortion should the section be lifted by one end, the design shown being intended for a permanent position. The sections of third rail *b* must be connected by wires to the live rails *d* as shown, which will enable the car to pass this section.

Mitre the joints of the rails and solder together to form a solid piece. The short rails *c*, must also be connected with the main rails *e*, so that the electrical continuity of the tracks may be preserved.

In Fig. 5 is shown a ground lever for throwing a switch. This lever is pivoted at *a* to a stand which is fastened to the tie. At *b* a link is pivoted which is fastened to the tapered end of the switch. In throwing the switch the lever is

thrown over and hooked under the catch *c*, which holds it in place against the tension of the switch.

A switch stand is shown in Fig. 6 which turns with the switch and shows a red or white light, depending on the switch position. Make a little stand *a*, of brass so that a stud fastened to the bottom of the lamp can pass through a hole and turn therein. To the bottom of the lamp is attached a short lever *b*, to which is fastened a link attached to the switch. This causes the lamp to turn a quarter turn with a full throw of the switch, showing white when closed and red when open. Make the lantern body of wire and provide the openings in the side with red and white glass. Inside the body is mounted a small pea lamp, connection with which is made by two

wires passing through the bottom. Adjust the lamp so that it will show white when looking along the main track, while the switch is closed and red when the switch is open.

A vertical switch lever and target is shown in Fig. 7. The stand *a*, is bend up from a $\frac{1}{4}$ " strip of No. 20 hard brass to the shape shown. Drill a hole at *c*, for the rod *d* to pass through and two in the ends for screws *e*. At the upper end of the target rod is fastened a target made of tin and painted in the colors indicated. The connection with the track is so made that the target will show white when the switch is closed and red when open. A handle *f* is soldered to the target rod at *b* with which the rod is turned, thus throwing the switch.

CUTTING TOOLS FOR PLANER OR LATHE

W. J. KAUF.

Planer tools will first come under our notice as being the simplest and requiring the least skill in setting. You have doubtless observed that if the chip be unwound from the spiral shape it assumes in leaving the tool, and projected in a straight line it is shorter than the surface from which it came. This is due mainly to the compression of the metal in the direction of the cut, and you will thus see the possibilities of saving power and strain upon the machine by giving proper cutting angles to the tools and reducing this compression to a minimum.

In Fig. 1 the cutting tool is at right angles to the work and without rake. It exerts its force in a direction nearly parallel to the surface of the work and having no side rake, either, it simply does not cut, but shoves or crowds the metal forward, producing a chip made up of little splints. It cannot exert any force tending to lift or curl the chip.

This tool is wholly wrong; nor would it materially improve it to grind like the tool shown in the little sketch at the right, which goes to the other extreme, and would spring into the work. A tool must first of all be heavy enough at the back or heel to resist the horizontal cutting force,

and consequently should have very little clearance. The 7 degrees clearance shown in the lathe tool in the upper view, Fig. 2, is too much for a planer tool, while the 3 degrees of the lower sketch is as small as can be used safely. Theoretically if the point leads by only a thousandth or two it will perform its function. There should be very little top rake on account of its tendency to make the tool dig into the cut; but this can be compensated for by giving considerable side rake.

Another reason why a planer tool tends to dig into the work is illustrated in Fig. 3. Point *A* in each sketch is the fulcrum. In the first sketch the tendency is for the tool to dig into the work in the direction of the arrow. This is not so serious as appears on the face of it, as planer tools are usually so stiff that they will spring but little and any error that might occur in the roughing cut would be eliminated in the finishing cut. What many mechanics take as an indication of the spring of the tool is really due to the chatter of the planer; since a rack and pinion planer will frequently chatter after it has become worn, while in a worm-driven planer the lost motion is all taken up at one end before beginning the cut and the screw action does away with the chatter.

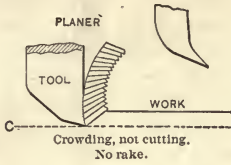

Fig. 1

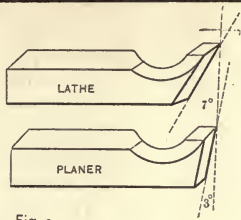

Fig. 2

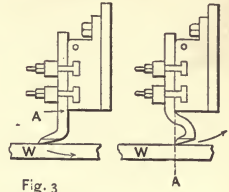

Fig. 3

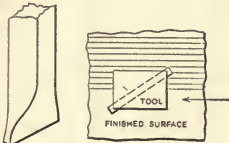

Fig. 4

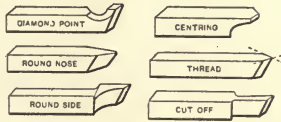

Fig. 5

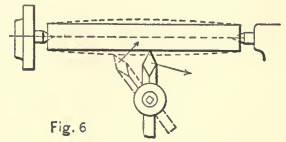

Fig. 6

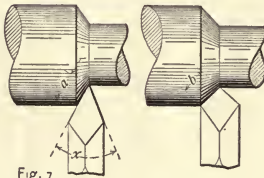

Fig. 7

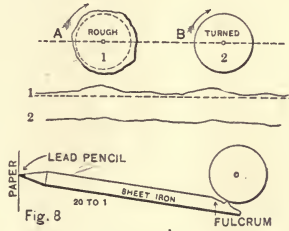

Fig. 8

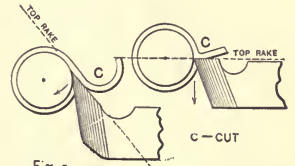

Fig. 9

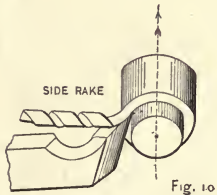

Fig. 10

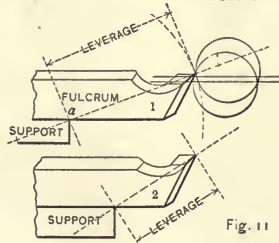

Fig. 11

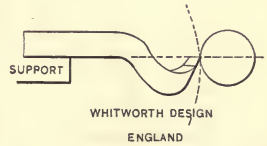

Fig. 12

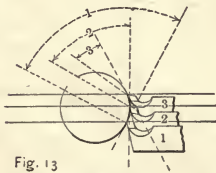

Fig. 13

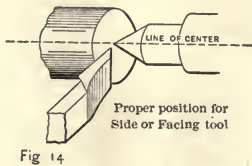

Fig. 14

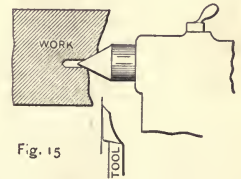

Fig. 15

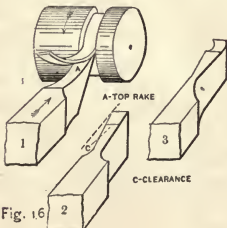

Fig. 16

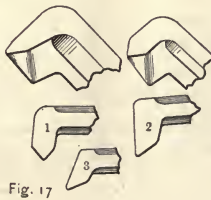

Fig. 17

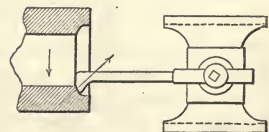

Fig. 18

To obviate any spring the tool may be designed as in the second sketch, Fig. 3, where the deflection due to the force of cut is away from the work in the direction of the arrow.

The tool in Fig. 4, approaches the ideal for a finishing tool, and gives the best finished surface of any that I have used on planer or shaper. It is made from a piece of ordinary tool steel and forged on the end in the shape indicated. It will be noticed that it has side rake and instead of being straight on the bottom, the line that comes in contact with the work is a little rounding.

We will now take up the subject of the cutting edges of some of the many varieties of lathe tools, Fig. 5. Here are shown a diamond point, a round-nose tool, a side tool, centering tool, thread-cutting tool, and cutting-off tool. We will first consider the diamond point as it is more of a universal tool than any of the others. Before speaking of rake, clearance or the setting of the tool, I want to call attention to the general form of the cutting edges and the importance of maintaining the same throughout the life of the tool.

Fig. 7 will best illustrate my meaning. The tool is shown at the left with depth of cut, and ground so that angle α shall not be less than 55° . To the right is a tool in which the angle has been changed by grinding on both sides of the point, only, because the machinist claims that he is in a hurry and must make time on his work. But it will be seen that the line of cut b is much greater than the line of resistance a , showing loss in efficiency in the tool and requiring more power to drive it after it had been ground. Nor is this the only reason why careless grinding will produce a loss, as I will proceed to prove.

This is true with proper rake, angles and clearances, but when the mechanic ignores all principles, and is careless besides, how much more serious it becomes, because more finishing cuts will be required to make the piece straight. The nearer the cutting edge of the tool comes to being parallel with the axis of the work the more power will be required to operate the tool.

It will be interesting to note what really takes place in turning, as shown in diagrammatic form in Fig. 8. Here is represented a piece of rough stock that is to be turned as indicated at the right. First, starting at the corner line A , and developing the line of circumference in a straight path,

we will get a line like (1). After turning and repeating the process, the developed line will look like the line at (2). It will be noted that the second line is somewhat irregular, showing that even after roughing it off, the surface of the piece has nearly all the irregularities of the rough stock, though on a smaller scale.

This brings us to another important point, and that is the necessity of centering work as accurately as possible, for no matter how even the work may be on its circumference, if centered out of true, it will not be round after turning. Why? Because the thickness of the chip or shaving is not uniform, hence does not offer uniform resistance to the cutting edge and the work will bend more at one point than the other. If the cut were uniform and offered the same resistance, of course we could expect round work.

The bottom figure on the sketch illustrates the tool and method of obtaining the lines. A long light lever has a knife edge or point at one end, near the fulcrum, which bears against the periphery of the work. On the other end is a lead pencil attachment, the point bearing against the piece of paper indicated, the paper traveling at the same rate of speed as the work, only in the direction of the axis of the work. An unevenness in the surface of the work raises or lowers the point of the pencil and as the ratio is great (20 to 1), the variation in the line is marked.

Referring to Fig. 2, we will take up the rake and clearance of lathe diamond point tools. The angle or clearance, sometimes called the angle of relief, as indicated here, is about 7° , and sometimes runs to 10° more or less; enough for a safe working angle. Really, the only reason for so much clearance is to avoid rubbing against the cut surface, thereby causing unnecessary frictional resistance to the motion of the lathe. Our efforts should be directed towards finding the angle that will give the least force required for cutting, combined with endurance of tool edge.

While the power required to cut is increased greatly by dullness of the cutting edge, we must avoid the wood chisel edge because time lost in constantly removing the tool for grinding purposes eats up the profit. In Fig. 9 are illustrated two extreme cases; that on the left, too great top rake and the other without any. The one will do good work for a few minutes, provided

the cut is not too heavy, but the wear of the edge is so great that the angle would soon become blunt and it would be very much better to have no top rake at all. On the other hand, the cutting wedge, as I will call the tool ends on the right, is too blunt to do good, clean work, and from the position in which it is set, the chip will come off nearly straight and in small pieces. The happy medium between the two is indicated in Fig. 10.

Side rake means the angle at which the top is ground either to the right or left side. A tool ground for a traversing motion toward the left-hand, cannot be used with a motion toward the right. Therefore side rake is designated right-hand or left-hand, the former being that which has its cutting edge on the right side and the latter on the left side. As the side rake is increased the power to drive it on its traversing direction becomes less as it tends to screw its way along.

Fig. 11 illustrates an important point in setting the tool. The further the cutting edge is from the base, or support, the greater will be the spring. Where this spring is possible the point is drawn into the work as indicated by the dotted line, and furthermore, will produce irregularly shaped work due to the variation in the resistance of cut at points where the tool digs in. This indicates the value of short leverage.

In Continental shops, and especially in England, it has become a recognized principle that the top of cutting edge of tool should not be higher than the top of the support and to obtain its top rake the tool is hollowed out by grinding. Sir Joseph Whitworth designed his lathes so that the tool set on the centre of the work, and any vertical pressure deflected the tool away from the work, as shown in Fig. 12.

Next in importance to the leverage of the tool is the angle at which it is set in relation to the work. Referring now to Fig 6, the tool is shown at right angles to the work and the cutting pressure tends to force the tool around to the right, away from the work, in the direction of the arrow, instead of causing it to dig into the work. If the tool were set as shown in the dotted position it will readily be seen than any slipping or deflection would carry it into the cut.

The third point to be observed in regard to setting the tool is its height relative to the lathe

centres. Fig. 13 illustrates this. Tool No. 1 is set below the centre and the dotted line, drawn tangent to the point of the tool on the periphery of the circle, indicates the direction in which the cutting force is applied. The top or cutting surface of the tool forms an angle of 90° with this line. The stock is thus merely crowded off by the tool and there is no cutting or wedge action but still not what it should have. The top tool, No. 3, gives us the best cutting wedge and will do maximum work with minimum resistance.

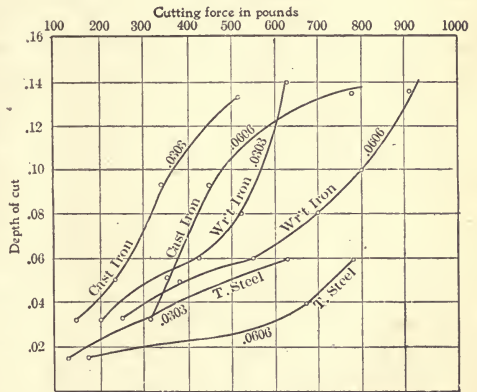

Chart showing Cutting Force. Industrial Press, N. Y.

From the foregoing it is clear that the lathe tool will do the best work with combination of top and side rake, when caught very short, at right angles to the work, and when set above the centre. This will lead to economy.

Now a point about grinding: The diamond point tool should be ground only on the top, and the angles on the sides should never be touched, and there will be no danger then that you will destroy the economic value of the tool. Many mechanics burn the cutting edges of the tool in grinding, by simple carelessness, which makes the edge softer than the metal it is supposed to cut. My references thus far have been confined entirely to the solid tools, most commonly used. But there are many improved tool holders in use, designed for self-hardening steel which is not affected by burning in the hands of incompetent mechanics, either in grinding or through of knowledge of the proper cutting speeds. These holders support the steel in such a position as to

give the proper front and side clearance and the rake is determined by the grinding.

Following is a table of finishing speeds and feeds for different metals for tools of ordinary tool steel. In roughing the axiom is slow speed and quick feed; finishing high speed and fine feed. From this table I should deduct 25 per cent. for roughing speed, making 18, 24, 28 and 83. Experiments on cutting tools made in the shops of R. H. Smith, London, England, and verified by the author, show that machine steel requires from two to two and one-half times the power for cutting, as does cast-iron, and wrought-iron, about one and one-half times the power. The results are given in detail in the chart herewith and show that an increased force is required for increased cutting speed.

LATHE AND PLANER CUTTING SPEEDS AND FEEDS.							
Tool Steel.		Wrought Iron Machine Steel.		Cast Iron.		Brass.	
S	F	S	F	S	F	S	F
24	25	32	25	38	22	110	20
Lub.		Lub.		Dry.		Dry.	
F = Number of revolutions to 1 inch feed.							
S = " " " feet per minute.							

The round nose tool, Fig. 5, is used for brass when made rather pointed and for facing cast iron when it has a blunt point. The tendency with brass, which is very soft, would be to pull a hooked tool into the work. The side tool should always be set with the point leading slightly, but remembering that it is not the point but the side of the tool that is to do the cutting. This tool should be set on the centre, as indicated in Fig. 14. Fig. 15 shows the necessity for facing up work with the side tool before turning; otherwise the centre will give more support to one side of the work than the other, and the pressure of the tool used later for turning will be likely to produce a crushing of the metal at the centre, on the side of the least support.

The centering tool should be ground like a twist drill and placed with its cutting point directly at the centre of the work and used to obtain an accurate centre for starting a drill. Much carelessness is exhibited in the use of the thread cutting tools not so much in grinding as in setting. It should be set so that the cutting edges are directly on the line of lathe centres and of course, at right angles to it. The economical

way to use this tool is to rough out the thread with a heavy cut and then regrind the top face until again sharp and then finish with a light cut. No matter how carefully a thread tool is used, the sharp point will wear rapidly.

Referring to Fig. 16, we come to the cutting-off tool, the last of the lathe tools shown in Fig. 5. The upper view shows the action of the tool and the two lower views indicate how good and poor results may be obtained through grinding. This tool has side clearance, right and left, and should be ground slightly concave on its top face. Its point should be on a level with the centre of the work.

In Fig. 17, are indicated several of the commoner types of boring tools. The vertical pressure on boring tools is very constant (Fig. 18), and when the tool starts to cut, the depression or spring downward remains very nearly constant throughout its entire cut, and so does not vitally affect accuracy. The tool wears as it advances, however, and this tends to produce a conical hole. Lathes are adjusted, also, so that in no case will they bore a hole larger at the back than at the front, and in making this adjustment the tendency is to have the lathe so it will bore very slightly smaller at the back; another reason why bored holes are frequently a little tapering.

Machinery.

A telegram from Ashkabad states that two million acres of cotton, wheat, barley, and vegetable crops in that fertile district of Russian Central Asia have been completely ravaged by swarms of locusts.

A 100" driving-wheel lathe, capable of taking in wheels of 100" diameter, is one of the new machine tools installed at the shops of the Chicago, Milwaukee, and St. Paul Railway at West Milwaukee, Wisconsin. In a test made with a pair of 84" wheels the tyres were turned simultaneously, with an average depth of cut of $\frac{5}{16}$ " at each tool and a feed $\frac{3}{16}$ ", says the *Engineer*. The cutting speed was 18 $\frac{1}{2}$ ' per minute, and the work was done in sixty-three minutes. The average power required at the motor was 16 $\frac{1}{2}$ ' horse-power, increasing to 22 $\frac{1}{2}$ ' horse power when hard spots were encountered by the tools.

BROWN PRINTS INSTEAD OF BLUE.

JAMES THOMSON.

The blue print as a means of artistic expression, is no doubt the simplest method of sun printing available for photographic purposes, but the Color is a serious objection, for the generality of subjects it will not do. In the photo miniature and in other directions we find instructions to enable us to change the objectionable blue to other colors, notably black and brown. The person who devised these methods must have had exceptionally good fortune in his efforts, or perhaps is one that is easily suited, for no one else, I am certain has ever succeeded in getting any other result than dingy prints from following the printed directions.

But why waste time in trying to make an imperfect way that which can be had to perfection by other more simple processes. For example, plain silver paper and kallitype. Eastman's sepia paper gives beautiful rich browns and is as cheap and simple in manipulation as the blue print. Some who have failed with it have had old paper forced upon them. Stale paper brings a train of disappointments.

The purpose of this article, however, is to instruct the readers of this magazine in a method of preparing for themselves paper in every way as good as those mentioned, and giving brilliant brown effects without toning, having the additional good quality of being as cheap and easy to produce as a blue print.

In one of my experiments I stumbled on this formula. Whether it is something very original I know not, but this I know: I have never seen it in any publication that has come my way. Whether new or old, it is something worth knowing.

For a foundation a good firm non-porous paper is essential, any paper that is of the nature of cardboard will not answer. A cream laid smooth surface writing paper will do, and if extra brilliant effects are desired a size of starch or arrow-root should be applied and then thoroughly dried. The salting solution is as follows.

Distilled or boiled water, 1 oz.

Citrate of iron and ammonia, 90 grains

Coat the paper thinly and evenly with this, either with a brush or tuft of absorbent cotton, and when surface dry complete by artificial heat. Then apply the sensitizer, which is herewith given:

Distilled or boiled water, 1 oz.

Silver nitrate, 50 grains.

Citric acid, 20 grains.

Press rather hard in coating so as to take off as much as possible of the superfluous iron solution from the surface, which if permitted to remain will make more than the desired contrast. Printing with the proportions mentioned is very rapid, a well defined tawny image being produced in a few minutes. Stop the printing before fully brought out, under print because the image will develop some in the washing. When printed wash away the unaffected salts as with a blue print, then transfer to the fixing bath composed of 2 grains of hypo to the ounce of tap water, where the print will immediately begin to darken. Three minutes in the hypo is usually sufficient; five minutes at most, as the image loses in strength when left too long. Wash for twenty minutes and dry between blotters or clean papers. The resultant prints should be a rich brown and may be further darkened by the application of heat. Should the contrast be too great dilute the iron solution (which regulates the contrast). However, if this is done, it slows the time of printing. The stronger the iron solution the quicker the printing and the greater the contrast, hence the value of this method for overtime negatives which ordinarily are useless. For rough papers it will be necessary to use say 60 grains of iron to the ounce of water. I have always used the iron and silver separately because I got good results, but these may work all right mixed just before applying and one coating made of it. The great drawback with the paper is its non-keeping qualities. It deteriorates quickly and no more than

can be used in twenty-four hours should be prepared at one time. Some one with more knowledge of the subject than the writer may be able to devise a preservative, making the paper thereby of more value commercially.

Such a paper ought to be of value to architects in producing easily and cheaply pictures of house illustration, etc.

Further investigation convinces me that prints should be left in the hypo. only so long as they retain their vigor and brilliancy, regardless of time. Some prints will reach their best in thirty seconds, while others can with safety be left five minutes. Long immersion causes fog and general deterioration. Properly manipulated, this process will produce prints to equal in graduation any Kallitype or Platinotype, while results from improper working are chalky high-lights and loss in the half-tones. *Western Camera Notes.*

The ratio between bore and piston stroke of modern petrol motors, according to the average of the motors fitted on cars taking part in the Automobile Club's trial, is 100, 115.6. The cylinder capacity averages 183.3 cubic centimetres per brake horse-power.

Prof. Lombroso has a curious prejudice against ambidexterity. In last month's *North American Review* he gives the results of his observations on left-handed and left-sided people. They are of such a character to make people hesitate even to stretch out the left hand, and it is small consolation for him to make the closing qualification: "I do not dream of saying that all left-handed people are wicked, but that left-handedness, united to many other traits, may contribute to form one of the worst characters among species." Even that he further discounts by bringing up the Tuscan proverb. "He is left-handed," as used to express the idea that a person is untrustworthy. The professor finds that among 1,000 soldiers and operatives the proportion of left-handed people is 4 per cent. among the men and 5 and 8 per cent. among the women. Among criminals the quota of left-handed was found more than tripled in men and more than quintupled among women.

MACHINE DRAWING.

CARL H. CLARK.

Fig. 1 shows the most common forms of riveting *a* is the ordinary cone head rivet, *b* the round head rivet, and *c* the countersunk head rivet, the latter being used where it is desired to have the surface flush, *d* shows the simplest kind of hand riveting where the head is formed by hammers only, it is left rounded with no particular care as to finish; *e* is the countersunk riveting, used where a smooth surface is desired, as in the plating of vessels, it is very slightly rounded as shown, *f* is the ordinary round head riveting, found by heading over roughly with a hammer and finishing with a swage, or cup shaped tool which is placed on the rivet and hammered, forming the head round. *G* is the best type of hand riveting, the head thus formed being a perfect cone, and care being taken to have it smooth and even. It is used in steam boiler work.

Any of the heads shown may be combined with any of the methods of riveting over, etc., according to circumstances, as for instance, in machine riveting both head and point are round to fit the cups formed in the machine.

Fig. 2 shows some of the ordinary types of bolts, *A* is a square headed bolt with a square nut. *B* is the three views of a nut, *C* shows a filester head with a hexagonal nut and a washer. This head is used where a good finish is desired. *D* is a tap bolt with a countersunk head, used where a flush surface is wanted; it is screwed in with a screw driver, *D* and *E* are used where a nut cannot be fitted, *E* is a tap bolt with a hexagonal head, *F* is a stud bolt with a double thread and a plain part between; it is screwed in until it reaches a bearing, after which the nut can be screwed on, Fig. 3 shows the three views of a square headed bolt with a washer and hexagonal nut, Fig. 4 is the working drawing of a simple cast iron bearing, Fig. 5 is a wrought iron eye bolt, Fig. 6 is a split pin, used to prevent bolts and pins from becoming displaced; it is put through a hole in the bolt and the ends separated enough to keep it from working loose. It is to be noted that in most machine drawings, especially the simpler ones, all of the three views heretofore used in projection are not required, as in Fig. 4 only two are needed, and in Fig. 5 only one.

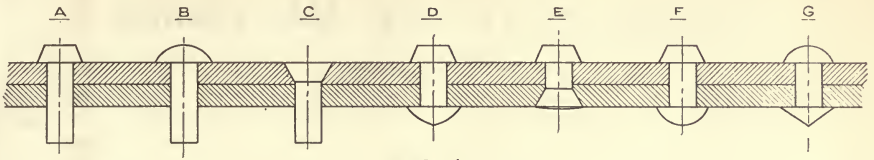

FIG. 1

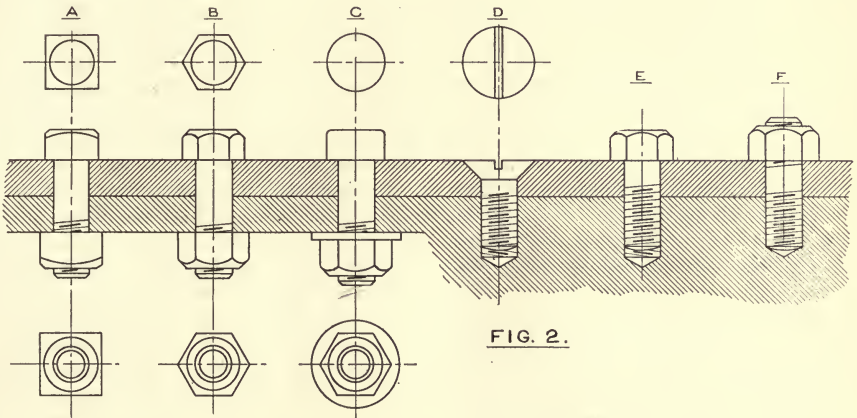

FIG. 2.

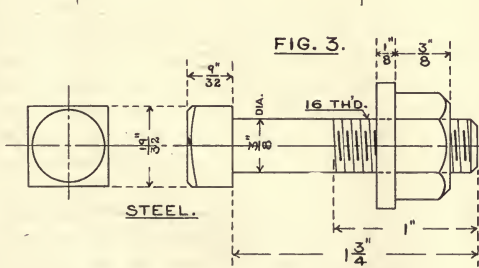

FIG. 3.

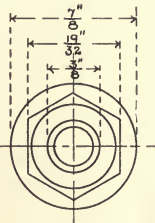

FIG. 4.

FIG. 5.

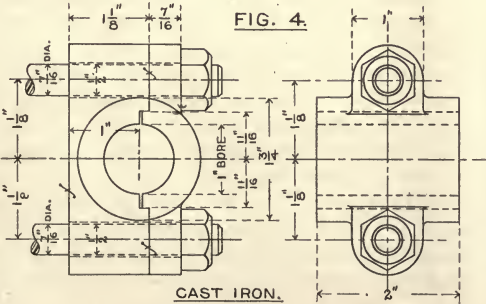
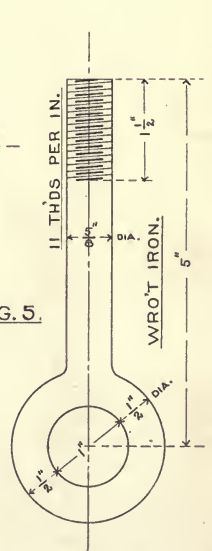

FIG. 6.

CAST IRON.

11 THDS PER IN.

WRO'T IRON.

MICROSCOPY FOR AMATEURS.

S. E. DOWDY. M. P. S.

The microscope nowadays plays such an important part in scientific work that its claim to be called an instrument of precision and value is hardly likely to be disputed.

Microscopy as an intellectual pastime has, however, to a great extent been neglected for the pursuit of other branches of natural science, and yet microscopy can lay claim to advantages not possessed to anything like the same extent by its rivals in the esteem of the youth of scientific proclivities.

In the first place, the instrument is comparatively inexpensive, it takes up little room, interesting objects are always available, and favorable conditions for viewing them are well within the observers control. Without wishing for one moment to disparage the pursuit of that branch of astronomy which particularly appeals to the amateur—viz., telescopic observation of stars, planets, and nebulae, can as much be truthfully claimed for the astronomical refractor or reflector? Of course, there is no reason why the two branches of science should not be taken up by the same person to advantage, the training to which the eye is subjected in microscopical work being conducive to more accurate observation of detail in astronomical work with the telescope; but if it is desired to keep to one subject, I for one do not think the beginner will be disappointed if he gives microscopy the preference. An erroneous impression no doubt exists that special skill and study are required, even if the microscope is to be used for recreation only. This is far from being the case, as any intelligent person should be capable of deriving profitable amusement after a few hours possession of the instrument. At the same time no piece of apparatus requires more technical skill to handle it, if first-class results in critical research work are desired, and this in itself, by developing the individuality of the observer, constitutes one of the most forcible arguments in its favor from the educational point of view. Neatness, patience, dexterity in manipulation, are required of the successful microscopist,

and the acquisition and cultivation of these qualities will fit him for success in other, perhaps widely different, spheres of activity.

Realising that it is frequently due to very hazy notions as to the cost, capabilities, and usefulness of the microscope, that many a would-be microscopist is deterred from taking up this fascinating study, with the Editor's kind permission, I propose to pen the following hints and suggestions for the use of those who are quite unacquainted with this branch of science. For this reason I have used the term "Microscopy for Amateurs" at the head of these communications. In the strict sense of the term, most of our leading microscopists are amateurs, pure and simple. In this case the reader must take the word as synonymous with beginner. Starting with a few explanatory words regarding the early history of the instrument, we can then proceed to a brief description of a modern student's microscope, indicating how its lenses and adjustment may be tested, and pointing out a few common objects for early observations, with the hopes that any feeling of interest in the subject which may perchance be aroused may not be transient, but may lead to the formation of those habits of accurate observation which have in the past and will in the future do so much to enrich the sum of human knowledge.

The name of the first person who conceived the idea of enlarging the images of minute natural objects by means of lenses is unknown. The origin of the microscope is therefore still wrapped in obscurity, the credit of its invention being ascribed to first one individual and then another, as fresh evidence comes to light. Some claim the honor for Galileo, others for Janssen, a Dutch optician, though they are by no means the only candidates in the field. The probability is that in its simplest form, as a convex lens, it was known at a much earlier period; possibly to the Romans or Egyptians. It is fairly safe to assume that the compound microscope was not known before the invention of the telescope,

which probably preceded it; but the actual date of its origin, or the name of its originator, is a matter of doubt. At all events, it is a comparatively modern invention, taking the length of the civilized period of the earth's history as a standard. From a plaything for the scientists of the Middle Ages, it has won such recognition of its capabilities and adaptability that no modern laboratory, medical school, or similar scientific institution can dispense with its services.

Great simplicity of construction marked the earlier stages of the history of the microscope, the mechanical adjustments, as might be expected being crude in the extreme. This, however, was in keeping with its optical portion, which, owing to want of knowledge of the laws of light and methods of giving the necessary curvatures to the lenses, was, of course, defective. This fact probably induced the great naturalist, Leenwenhoek, to discard the compound for the simpler microscope, which could at that time be relied upon to give more faithful images. The possibilities of the compound instrument were, however, not lost sight of, and we find various modifications introduced from time to time, until about the year 1800 it began to assume much the general outline with which we are now familiar. It was also about this time that the optical portion was receiving increased attention, and though the theory of the achromatism of lenses was imperfectly understood, we find attempts being made to give the necessary correction to the objectives, so that clearer images might be obtained. To enter fully into details concerning the evolution of the modern microscope would fill a fair-sized volume, a few lines cannot do justice to it.

To those interested in the subject, a perusal of that part of "Carpenter on the Microscope" devoted to the history of the instrument will show that the modern instrument is the result of much patient work, with which the names of many famous men of science have been connected. Of late years strenuous efforts have been made to incorporate the results of the latest researches in certain branches of chemistry and mathematics in the preparation of glass and the figuring of lenses, with the result that a first-class modern microscope is a triumph both for theoretical and applied science. What is still more important to the amateur, though, is the fact that, through

increased interest in the subject and competition amongst readers, a really excellent microscope can now be obtained at a very low cost. After the purchase of such an instrument; a very small additional outlay will enable the beginner to do good work with it; or if recreation be the end in view, many pleasant hours may be spent in its company, and a first-hand acquaintance with some of Nature's minute marvels be made; an acquaintance which, in the majority of cases, will deepen the wish for a more intimate knowledge of the subject.

The history of lead pencil making goes back three or four hundred years. The lead pencil derives its name from the fact that before the time when pencils were made from graphite, metallic lead was employed for the purpose. Graphite was first used in pencils after the discovery, in 1565, of the famous Cumberland mine. This graphite was of remarkable purity, and could be used without further treatment by cutting it into thin slabs, and encasing them in wood. For two centuries England enjoyed practically a monopoly of the lead pencil industry. In the eighteenth century, however, the lead pencil industry had found its way into Germany. In 1761, Caspar Faber, in the village of Stein, near the ancient city of Nuremberg, Bavaria, started in a modest way the manufacture of lead pencils, and Nuremberg became and remained the centre of the lead pencil industry for more than a century. For five generations Faber's descendants made lead pencils. Up to the present day they have continued to devote their interest and energy to the development and perfection of pencil making. Eberhard Faber, a great-grandson of Caspar Faber, emigrated to the United States, and, in 1849, established himself in New York City. In 1861 he erected his pencil factory in New York, and thus became the pioneer of the lead pencil industry in the United States. Since then four other firms have established pencil factories there. Wages, as compared with those paid in Germany, were very high, and Eberhard Faber realized the necessity for creating labor-saving machinery to overcome this handicap. Many automatic machines were invented, which greatly simplified the methods of pencil making, and improved the product.

AMATEUR WORK

77 MILBY ST., BOSTON

DRAPER PUBLISHING CO., PUBLISHERS.

A Monthly Magazine of the Useful Arts and Sciences. Published on the first of each month for the benefit and instruction of the amateur worker.

Subscription Rates for the United States, Canada and Mexico \$1.00 per year. Single copies of any number in current volume, 10 cents.

TO ADVERTISERS.

New advertisements, or changes, intended for a particular issue, should reach the office on or before the 15th of the previous month.

Entered at the Post-office, Boston, as second-class mail matter Jan. 14, 1902.

NOVEMBER, 1903.

The "Suggestion Offer" is again called to the attention of readers. Anyone sending us a brief description of anything which would be of general interest, and which is accepted for publication, will be given the choice of any premium in our premium list offered for one subscription, subject to any condition of extra payment mentioned. Suggestions, to be acceptable, should give sufficient details so that the subject can be properly written up by one of our staff writers. When possible, drawings or a photograph should also be sent. Quite a number of our subscribers have received premiums under a previous offer, which is now made open at all times.

The premiums selected to supplement the Grand Premium offer made in the September number of a Screw-Cutting Lathe are as follows: For the second largest list, Choice of either a Kent Dynamo-Motor, or a Rich Drawing Outfit. For the third largest list, Set of Fine Drawing Instruments. For the fourth largest list, Choice of a Seavey Mitre Box, Volt or Ammeter or Water Motor.

These are to be given in addition to the regular premiums allowed for subscriptions. A little extra work before the end of the year may secure

one of the extra premiums. Make a trial and see what you can do.

The second volume of this magazine, Nov. 1902, to Oct. 1903, is being bound in cloth, and will be ready about the time this number is issued. It will be sent, postage paid, for \$1.50 or with a subscription for one year to begin with any number for \$2.25. A reprint of the first volume is in progress, a copy being sent, postage paid, for \$1.50.

Renew your subscription promptly. This is one of the matters likely to be overlooked unless attended to at the proper time.

BOOKS RECEIVED.

DISEASES OF GASOLINE AUTOMOBILES AND HOW TO CURE THEM. A. L. DYKE AND G. P. DORRIS, 210 pp. PRICE \$1.50. A. L. DYKE, ST. LOUIS, MO.

The rapid increase in the use of gasoline engines as the motor for automobiles, launches, and stationary purposes has, as might have been expected, been the occasion for numerous books and other publications devoted to the same. The one above mentioned contains a great deal of information which would certainly be of great value to engine operators and owners. A novel yet valuable feature of this book is the large number of clippings from the various publications and answers to same which have been included as a part of the matter presented. Numerous illustrations supplement the text. Had the typographical work been better the book would have presented a more satisfactory appearance, but in view of the information conveyed this will be overlooked by most readers. It is certainly well worth the money to any owner of an automobile fitted with a gasoline engine.

THE A. B. C. OF PHOTO-MICROGRAPHY. W. H. WAMSELEY, F. R. M. S., F. A. A. A. S. 155 pp. PRICE \$1.25. TENNANT AND WARD, NEW YORK.

This book is intended for those who are totally unacquainted with this most interesting branch of scientific work, and gives with much detail the instructions necessary to surmount the obstacles which beset a beginner, a feature not covered by other works upon this subject. To those who are not familiar with the subject matter of this book, yet who delight in photographic and microscopic work, the reading of its pages will be extremely profitable. Thirteen plates illustrating photo-micrographical subjects add much to its value. It's well and plainly written and is certainly a valuable addition to the literature of this subject.

A BENCH MICROMETER.

R. G. GRISWOLD.

A bench micrometer is a very handy tool for the amateur who is doing a high class of work in which accuracy of measurement is essential. In the physical laboratory it is almost indispensable for comparison of lengths. While it is an instrument of precision, its construction is not difficult to those accustomed to using tools and a lathe. It should be understood that in a tool of this kind, care in the making is repaid a hundred-fold in the finished article.

The capacity of the instrument about to be described is from five inches down to zero, reading in thousandths of an inch and a ten-thousandth may be easily estimated by the eye, or the index wheel may be further divided to read to this, as the circumference is sufficiently large to

The beam, which is 10 $\frac{3}{4}$ " long x $\frac{3}{4}$ " in diameter should be turned down from $\frac{1}{8}$ " stock and if possible, finished by grinding, so that it may be true to size and perfectly straight. If it cannot be ground conveniently, then finish it with a fine grade of emery cloth wrapped over the end of a stick and held in a tool post of the lathe. By

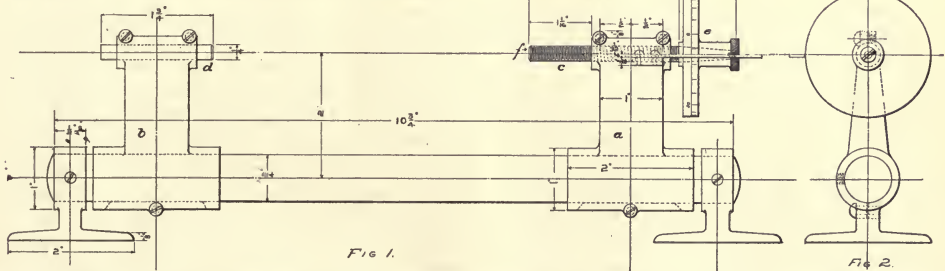

permit such divisions being easily read. The travel of the micrometer screw is one inch, and with the aid of distance pieces the two measuring points may be set to measure any distance within its capacity.

Considering the frame or bed first, we have two pedestals upon which the instrument stands on the bench or table. These may be made of either cast iron or brass, turned to size and polished. The under side of these pedestals should be slightly recessed, either in the pattern, or by running a light cut over the surface in the lathe. This will enable the instrument to stand more firmly upon the table. The beam passes through $\frac{3}{4}$ " holes drilled and reamed in the ends, being held in position by the set screw shown.

running this to and fro over the surface with plenty of oil, a satisfactory surface may be had.

The two stocks carrying the measuring points are made from the same pattern with the exception of the lug which carries the small scale along which the index wheel passes. This may be cut off the stock *b* when cast, thus saving an extra pattern. If a lathe is convenient the longitudinal holes in these stocks should be drilled on it in the following manner:— Make a small angle or "knee" plate which can be bolted to the face plate of the lathe, being careful to have the two sides at right angles. Secure the stock, which should previously have been finished by filing until nearly to size, to this angle in such a manner that the axis of the hole to be drilled will coincide with the

center line of the lathe centers. This clamping is most readily accomplished by passing a flat piece of iron, say 1" wide by 1-4" thick, over the piece and passing two small bolts through holes in the ends into the angle plate. When securely fastened, place a drill slightly smaller than the finished size of the hole in a drill chuck held in the tail stock, and carefully drill the holes for the measuring point and the beam. By simply moving the angle plate across the face plate without loosening the clamp on the piece, the two holes may be drilled parallel, which would be difficult if either hole was drilled after removing the piece. Before passing from one hole to the other, pass a reamer through them to finish to size. It is well to state that the hole in stock *a*, which carries the movable screw, should be drilled to the root diameter of the screw to allow of threading, which must be done without moving the piece on the face plate after drilling the hole. Make a small thread tool which will pass into the hole and secure in tool post. Set the gears to cut 40 threads per inch. Take very light successive cuts, as this will ensure a perfect thread and avoid to a great extent the springing of the tool which would make an uneven thread.

When these holes have been finished, the piece should be split with a small saw as shown, and two machine screws provided at the top and one at the bottom to serve in clamping the spindles fast. The split in the bottom does not extend from end to end but stops about $\frac{3}{16}$ " from either end. The screw in the middle will compress the sides sufficiently to firmly grip the beam, and the ends of the hole not being cut through makes an excellent guide. This split is put in with a small circular saw, but if one is not convenient, the split is run completely through as in the top.

The spindle *c* should be made of tool steel and hardened after the thread is cut, but as this process generally warps the piece, unless the amateur is familiar with this class of work it would be better to leave the body soft and only harden the end which comes in contact with the piece to be measured. Cut the thread 40 per inch and make it a snug fit in the stock *a*. The end upon which the index wheel fits is tapered and the wheel held thereon by a screw in the end. When this spindle is inserted in its nut, the binding screws should be set down with only sufficient force to

make the screw turn firmly, or with a slight resistance and with no lost motion. After the end *f* is hardened, the spindle should be held in a chuck and the end ground perfectly square and flat. If no tool-post grinder is handy, the same result may be more slowly attained by fastening an oilstone slip to a flat piece of wood, or the flat side of a tool, and while bearing gently against the end of the rapidly revolving piece, move the slip in and out by the cross-feed screw.

The index should be turned out of a piece of steel, but brass will do and may be cast roughly to shape and then turned to size. Fit it to the taper of the spindle and counterbore for the screw in the end. When finished, lay off the divisions on the edge as follows:—Cut from a sheet of hard glazed writing paper, a strip $\frac{1}{8}$ " wide and wrap it around the circumference, cutting the ends so that they meet exactly without any overlapping or clearance. Now lay the strip on a drawing board and divide it into exactly twenty-five parts, making a light mark at each division. With a little patience each division may again be divided into ten parts, making two hundred and fifty divisions on the circumference. Now wrap the strip around the circumference again and fasten with a drop of glue or wax, allowing the edge to coincide with a fine line that was cut in the circumference while in the lathe. This will leave about $\frac{1}{8}$ " of clear metal exposed. Now coat this exposed surface with a little paraffine or beeswax and when cold, scribe the divisions on the wax, being sure to cut completely through to the metal beneath. Make the 0, 5, 10, 15, 20 and 25 divisions extend from the line to edge, the other divisions being about half that length. If the smaller divisions are to be laid off, make them just a little shorter so that they will be distinct, the middle or fifth division being longer than the rest

When this marking on the wax has been completed, brush over the cuts with a camels hair brush charged with nitric acid. Be sure that the acid penetrates to the metal, otherwise the etching will not be clear. Before washing off the acid, feel the marks with the point of a needle to make sure that there is a depression there deep enough to prevent the needle point from slipping. When the divisions are etched plainly, wash off all the acid and wax, finishing by rubbing the ^{cu}ts with oil to prevent rusting, which is one of

the troubles with freshly etched work.

To the stock *a*, attach the small scale which is made of No. 20 sheet brass. One inch is laid off on its edge in fortieths, every fourth division being made double length, dividing the inch into tenths. When this scale is attached, the circumferential line on the index wheel should coincide with the 0 division when the 0 division of the index coincides with the edge of the scale. Since the number of threads is forty per inch, each revolution of the index wheel will move the point $f \frac{1}{40}''$ and the index line will have advanced one division on the scale. Now if the index is moved a part of a revolution, say one division ($\frac{1}{25}$) the spindle will move $\frac{1}{25}'' \times \frac{1}{40}'' = 1-1000''$.

To set the micrometer to measure distances

from 1" down, bring the stock *b* up until the two spindles touch and clamp in position. If after clamping the two points do not touch exactly, as indicated by the position of the index, loosen the screws binding *d* and push up until perfect contact is secured. Then pieces may be measured between the two points.

For measurements beyond an inch, standard blocks must be inserted between the points and the setting thus made. The making of a set of standard pieces is a very interesting and profitable undertaking. They may be turned nearly to size from $\frac{1}{4}''$ Stubb's steel and then hardened. They are finally ground to size by hand. A set consisting of 1", 2", 3", 4" and 5" should be made for this micrometer.

A SPRING BOX COUCH.

JOHN F. ADAMS.

The upholstered spring couch here described will be found very convenient, as the box base has ample capacity for the storage of bed clothes, and wash dresses and other clothing can be kept therein without folding, a feature greatly appreciated by ladies. It is easily made at small expense.

The frame work is made of pin poplar or chestnut. The sides *a*, of the box base are 6' long 9" wide and $\frac{3}{8}''$ thick, the ends and bottom inside edges being rabbeted to receive the end pieces *B* and sheathing for the bottom. The end pieces *B* are 29" long and also rabbeted for the bottom. The bottom *C* is $\frac{1}{2}''$ matched sheathing. The joints of the frame are glued and firmly nailed with wire nails, a few screws adding to the strength. Circular blocks, 3" diameter and $1 \frac{1}{2}''$ thick are screwed to each corner for receiving castors. The frame of the top should be firmly made. The side pieces *D*, are 6' long, $2 \frac{1}{2}''$ wide and $\frac{3}{8}''$ thick. The end pieces *E* are 28" long, $1 \frac{3}{8}''$ wide and $\frac{3}{8}''$ thick, the upper edges of *D* and *E* being flush, the joints being glued and firmly screwed. The pieces *F* are 6' long, $2 \frac{1}{2}''$ wide and $\frac{1}{4}''$ thick, and are firmly nailed to the inside lower edges of *D*. Similar pieces *F'* 23" long,

and 4" wide at the ends are nailed to the under edges of pieces *E*, and corner nailed to *F*, also glued at the ends to *F*, or a firmer joint secured by halving in which case these pieces are 28" long.

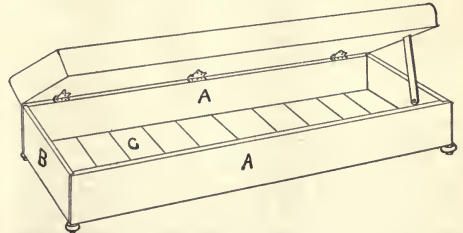
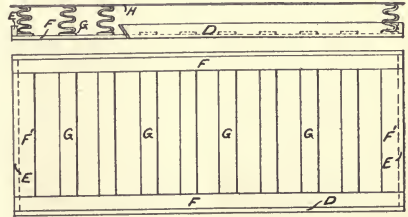

To hold the springs, 10 strips *G*, 28" long, 3" wide and $\frac{1}{2}''$ thick are glued and screwed to the pieces *E*, one at each end, and the others spaced

7 $\frac{1}{2}$ " between centres. A piece of $\frac{3}{8}$ " steel wire *H* is bent to the shape of the frame with round corners, the ends being lapped about 3" and fastened by winding with wire after filing a few notches in the outer edges to prevent the ends from working apart. Four springs are fastened to each cross piece *G* making 40 springs in all, those on the ends being flush with the ends of pieces *G*, and the others spaced equally between them. The springs, which should be fairly heavy, are attached to pieces *G* with strong staples, and the tops laced with heavy manilla cord to hold them upright and prevent them from getting out of position or shape. The spring wire edge *H* is also firmly corded to the springs which it touches thus giving a firm yet flexible edge.

With the springs fastened as directed, a covering of heavy burlap or canvas is then put on, the springs being sewed to same with a few turns of upholstering twine. The edges are firmly tacked to the upper edges of the pieces *D*, not to the sides of same. A layer of hair, Florida moss, hemp or such other material as the maker may prefer, is evenly placed over the covering of the springs, using care to see that no bunches are left. The covering of corduroy or figured upholstering

material as preferred, having been previously fitted and sewed, is then put on, the edges being tacked to the under edges of pieces *D*.

A corded edge adds to the appearance, this work being done on the sewing machine. The top width is about 31" and the sides and ends 8" allowing 1" for turning under and tacking. The covering for the box base is 11" wide, $\frac{3}{4}$ " on each edge being turned and tacked to top and bottom edges of *A* and *B*. If striped material is used, the stripes on the sides and ends should run lengthwise. The top is tufted by sewing between each row of springs, buttons covered with the same material as covering being used. The under side of the top and the inside of the box are covered with figured cotton goods, tacked with small upholstering tacks, the top being previously attached to the base with three T hinges. A special spring fixture is used by manufacturers of such couches, which by means of strong springs enables the top to be easily raised or lowered, and if obtainable, are desirable to use instead of hinges. If the latter are used, supporting sticks for holding up the top should be attached to each end with thick screws, as the weight of the top is considerable.

A POWER DORY.

CARL H. CLARK.

IV. THE DECK.

After the deck is laid and trimmed off, the top of the stern board should also be trimmed 3-4" above the level of the deck, and to the same curve. The stem is cut off and shaped as shown in Fig. 2 with a 3-4" hole bored to take a rope if desired. The face of the stem has been preferably left 3-4" wide, and a piece of 3-4" flat or half round galvanized iron or brass strip is bent around and fastened into place with screws. At the top it is carried up and around the curve, and the lower end extends a foot or so along the bottom.

The washboard *L*, Figs. 2 and 3, is of oak, about 6" wide and 1-2" thick. The stock for this should not be very dry, as it must be quite limber to bend sharply enough. It should be in two pieces, joined on the sides. A steam box, as before described, may be necessary for this purpose, as it must be thoroughly steamed. When bent into place it is fastened with

screws. Before boring for the screws, a centrebore should be made about 1-4" deep, and slightly larger than the head of the screw, so that the latter may lie below the surface. The counterbore is then filled with a plug or "bung" cut for this purpose across the grain, that it may be planed off smooth. These plugs are obtainable from any dealer in boat supplies in even sizes. They are set in lead paint and then trimmed down to the surface of the board.

The two parts of the washboard are to be joined by a piece about 8" long put on the outside; the ends of the two parts being screwed to it. A rowlock socket is afterwards fitted on the top of the joint, to enable the use of oars when desired.

It is desirable that the deck should be covered with canvas, as it makes smoother work, and is easier to keep in good condition. Canvas for this purpose

should be about 8 oz. weight, in one width if possible, or it may be in two widths, lapped in the centre. It is cut about to the shape of the deck and washboard, leaving some for trimming. The deck is smeared with lead or thick paint, and the canvas laid on, drawn tight against the washboard and over the edge of the deck and tacked. A piece of about 3-8" quarter round moulding is then fitted in the corner between the washboard and deck and the canvas trimmed off at its upper edge. This makes a good water tight joint. The outer edge is covered with a half round moulding about 1-4" wide, which should be left bright and later varnished. Around the stem and across the stern the edge of the canvas is turned under and neatly tacked.

The skeg *O, P*, Fig. 2, is of hard wood 3-1-2" thick, shaped as shown, the after edge of *P* is to be square with the line of the shaft. They are joined together diagonally as shown and nailed. The size of the skeg as shown, is sufficient for ordinary work, but for some uses it may be desirable to increase its size. If this is desired, the length may be increased, but should not be longer than half the length of the bottom. It is fastened to the bottom with 3-8" rivets.

The flooring is laid directly upon the moulds and is 3-4" thick; on the top of the cleats already in place between the moulds a strip is nailed to support the flooring between the moulds. It will be best to fit it now but not fasten it in place until the engine is installed. The middle board should be left loose to allow access to the space underneath. It will be well to fit a narrow piece at the outer edges of the floor extending diagonally down to the planking to keep articles from rolling down under the floor.

Seats are to be fitted as shown in Figs. 1, 2, 3, about 15" above the floor. They are supported on short braces fastened to the moulds and an upright under the outer end. The seats may be notched around the moulds and extend out to the plank, or they may run along on the inside of the moulds with a narrow strip along the back to prevent articles from rolling behind.

The space under the seats may be left open, in which case turned uprights should be used under the seats, or if desired, sheathing may be carried as shown in Fig 3, and doors fitted to give access; this gives valuable storage space. Before fitting the bulkhead forward, the fuel tank is to be put into place.

If a complete outfit is purchased the fuel tank is a part of it, and all that is necessary is to fasten it into place. If however, it should be necessary to have a tank made, it should be about 10 or 12 gallons capacity, and of copper or galvanized iron, riveted and soldered; too much care cannot be taken to make this tank absolutely tight, as any leak will cause great danger to boat and occupants. A round tank is most easily made, and one 12" diameter and 20" long will hold about 10 gallons. The tank must be kept as high as possible, and if greater capacity is desired, a flat tank should be used.

The dimensions of the latter can be taken from the boat. It is suggested however, that a tank 18" long, 24" across the after end, 12" across the forward end and 8" deep will be of about the proper size. It should be arranged to fit closely up under the deck and the filling pipe should be arranged to extend up to the deck so as to leave no open space, and should have a screw cap with a small hole in it.

The opening in the deck can be covered with a brass cap of some sort. The outlet from the tank should be a plug cock with a union on it and should be strongly soldered to the tank. When the tank has been fitted into place it is supported by cross braces and must be blocked so as to prevent it from shifting as the boat rolls. It has been suggested to the writer that, since leakage of gasoline is such a dangerous matter it would be well to line the space under the tank with lead or zinc, or make a tray which would fit under the tank, and thus catch any possible drippings and prevent its running aft to the motor, where it might become ignited. The arrangement just outlined for the interior is merely suggestive, and any other desired arrangement may be carried out equally well.

The bulkhead is of 5-8" tongued and grooved sheathing, and is nailed at its upper edge to a strip nailed on the under side of the deck beam; cleats are fastened to the plank to take the lower ends of the boards. The boards should be shaped to fit to the plank as closely as possible and make a neat joint. An opening should be left, and fitted with a hinged door, as the space is valuable for storage. There will also be a bulkhead at the after end of the standing room, but it cannot be fitted until after the engine has been installed.

The rudder and skeg are of metal, the plate is about 3-16" or 1-4" thick, about 15" wide and 19" deep, cut to the shape of Fig. 2. The stock is 1" diameter, and of the proper length measured from the boat. It will be best to have a blacksmith get out the stock as it requires to be heated and split to allow the insertion of the plate; holes are then drilled and the two riveted together. The lower end has a 1-4" hole for a split pin and the upper end is squared and has a 1-4" hole through also; the square part being about 1" long.

The skeg is of flat iron 2" x 1-2" shaped from the boat, the end being bent over as in Fig. 2 and bored to fit the lower end of the rudder stock. Both skeg and rudder ought to be galvanized if for use in salt water.

A cheaper way of making the rudder, although not as good is to use a piece of 1" gas pipe for the stock; which is drilled with several 3-8" holes. The body of the rudder is made up of 1" stock which is bored with 3-8" holes to correspond; iron rods are then driven through all and the ends headed over. The lower end has a piece of rod welded or riveted in with the 1-4" hole before mentioned, and the upper end has a 3-8" hole for a pin through the tiller. This makes a very good rudder if well made, and is much cheaper

than the other, and easier to make. The sleeve shown is put in to make a tight joint where the stock goes through the stern board. It is a piece of pipe about 8" long, a loose fit for the rudder stock and preferably threaded. The tiller should be about 18" long, with a square hole to fit the top of the rudder stock and a hole in the small end for the wheel ropes. It may be cast from a rough pattern, the hole drilled and then filed square, or it may be purchased from a dealer in launch outfits.

In setting the rudder in place the sleeve is first set by boring through the stern board. In order to bore at the required angle a piece of board can be nailed both inside and outside; to enable the bit to be started square. The sleeve is then screwed into place and the outside block split off; the inside one would best be left to steady the sleeve. It should be so adjusted that the tiller will rest on the top of the sleeve with a washer between and take the weight of the rudder. The tiller should be a close fit on the square end of the rudder, and a pin put through the hole above the tiller. The skeg is so shaped and adjusted that it supports the rudder and allows it to swing freely. The rudder should not be put in place permanently until after the engine has been installed. A locker is to be constructed on each side of the engine, about a foot wide, and at about the height of the seats. One of these will accommodate the batteries, spark coil, etc., and the other can be used for tools, etc.

The steering wheel can be placed either in the forward end of the standing room or on the side, just forward of the engine, or, if desired, two may be used. The wheel is fitted with a drum about 4" diameter and 5" long and can be purchased complete if desired.

Pulleys are fastened to each side of the boat just opposite the wheel, and about 3" aft of the hole in the tiller, to take the tiller ropes. For these ropes either a small wire rope or braided line can be used. Holes are bored in the tops of the moulds just large enough to allow it to pass. Four or five turns are taken around the wheel, and the ends made fast to the hole in the tiller. A very simple arrangement is a lever pivoted vertically just forward of the engine and extending about 8" above the wash rail; the steering ropes are connected to it and by moving it forward or back the rudder is controlled.

The hole for the shaft can be bored about 11-4" diameter. It must line up with the bed and be in the middle of the deadwood *P*. Specific directions can hardly be given for this work, but it will probably be well to bore from the outside, making first only a small hole. By drawing a wire through the hole and stretching the end out over the bed, the direction can be noted and any change in direction made in boring the full sized hole. If the hole does not come quite right it may be trimmed out on the inside end with a gouge.

A large heavy cleat, either of galvanized iron or wood should be fastened on the forward deck with bolts, for

making fast the mooring line, and a similar one on the after deck for towing and similar uses. These cleats should point fore and aft, and should be strongly bolted to the beams. It is also a good idea to fit under the corner of each plank for the space of about 10', amidships, a piece of quarter round moulding. This protects the corners of the plank, and presents a rather even surface.

The hull is to be smoothed down with sandpaper, all nail holes and cracks filled with putty and painted with two coats inside and three outside. The wash rail and other bright parts are covered with two coats of best spar varnish. If for use in salt water, the bottom up to about 2" above the water line should be covered with some form of anti-fouling preparation. The last coat of paint should not be put on until the engine has been installed and the boat is ready for the water.

These directions are supposed to complete the construction of the hull, except so far as the individual builder sees fit to arrange for himself. The installation and fitting out of the engine will be described in the next and last chapter.

NOTE — For the convenience of those who may wish to purchase their engine in the fall, and thus take advantage of lower prices then prevailing, the writer would say that the power recommended is about 2 or 2 1-2 H. P. A 1 1-2 H. P. engine can be used if high speed is not desired, but a 2 or 2 1-2 H. P. will be found to be better in every way. In case a 2 1-2 H. P. size is not obtainable in the make desired, a 3 H. P. engine will not be out of place, and will make a very powerful boat. As many manufacturers rate the capacity of their engines differently, purchaser will be obliged to consider the dimensions of engines when making comparisons of power.

Prof. Nikolaus Artemieff, of Kien, Russia, invented some time ago a protecting suit, consisting of an overall, with sleeves, gloves, headgear and so on, and made up of fine copper wire, interwoven in cloth, the idea being to protect the human body from dangerous currents by short circuiting with the copper. Such protecting suits, according to the Electrician of London, are now being put upon the market by Messrs Siemens & Halske, in Germany. They are said to be so dimensioned that a current of 200 amperes may flow continuously through the protection without producing undue heat, and a current of 600 amperes for a few seconds without injuring the operator.

In actual tests made with a 20 kilowatt, 150,000 volt transformer, it is stated that any two points at this pressure could be short-circuited by the operator without any injury to the body whatever. In touching two points of different potential no contraction of the muscles took place. The resistance of the protecting suit, measured from hand to hand, is stated to be 0.01 ohm, so that 1000 amperes would produce a potential difference of 10 volts.

PRINTING FOR BEGINNERS.

FREDERICK A. DRAPER.

I. INTRODUCTORY.

While much has been written upon this important subject, and many books are available for those who desire to make a study of it, yet it is the belief of the writer that these books are designed for those who are pursuing their work in fully equipped printing establishments. It is thought therefore, that this series of articles, prepared especially for those totally unacquainted with the work and lacking the guidance of experienced workman close at hand, will be found interesting and valuable, especially to those who desire to begin in a small way, extending their field of work as experience is acquired. For this reason, special prominence will be given to the many small economies which, in a small shop, are both desirable and necessary for the production of work at a profit, and without heavy expense for materials.

To the one making a start with a shop of his own, the question of an outfit is a most important one, for unless a well filled pocket book can be drawn upon, the expense for bare necessities will seem comparatively large, and the range of available work, extremely limited. For this reason, it might be well to give attention to the various kinds of work which are within the capacity of a small shop, and to the ways, in which a small beginning can be built up without excessive cost. Most careful thought must be given to selecting the necessary type and materials, so that everything obtained shall be usable to the fullest extent. The catalogs of the large dealers in printers' supplies are so attractive that the novice will succumb to the alluring inducements of new and attractive faces of type, labor saving machines, etc., and soon find himself stocked with much unproductive equipment, which more care and thought would have avoided.

Keeping this in mind, the first consideration is the fields of profitable work open to a beginner with a small shop; the requirements of the amateur who would print a small paper "for fun," will also receive attention. It hardly needs mention that the printing business as with any other, requires a location where the desired number of customers can be secured, the ability to secure them depending upon the personal popularity, financial and mechanical skill of the printer, and capacity of the shop. Assuming that these are sufficiently promising to warrant a start, what shall be the lines of business to be solicited and for doing which the shop is equipped?

In answering this question it will be assumed that, on the score of expense, a special line of work is first

to be undertaken, ways for subsequent development being given, and utilized as local conditions may warrant. Among the several lines included in these conditions, is that of visiting and business cards. Acceptable work of this kind can be done with a small assortment of type, a small press and few accessories; the profits average greater than in most lines, and business can be more easily obtained. This is especially true if the location is in a large city where conventions are numerous. A young amateur of the writer's acquaintance, makes a specialty of visiting the first sessions of conventions held in the city where he resides, interviewing the delegates, many of whom are unprovided with cards, and as quick delivery is promised receives numerous orders, at very profitable prices. With such orders, the style is nearly uniform and the work quickly done. A stock of blank cards of suitable size is kept on hand, and time is economized to the best advantage to turn out quickly the maximum amount of work. Should a reader not be so fortunately situated, a canvas among the professional and business men of any large town or city, will find many without cards, and willing to give an order to any bright young man who attractively presents his business. Closely associated with this line is that of admission tickets for entertainments, programmes for same, and dance orders, invitations, millinery openings, postal card announcements, etc., which can be broadened to include bill and letter heads, statements, envelopes, blotters, etc. These lines are selected as the paper and card stock can be purchased of paper dealers cut to size, thus dispensing with the use of paper and card cutters, both expensive machines, the purchase of which is warranted only by a business exceeding the capacity of what is here termed a "small" shop.

We will now consider the appliances necessary to a proper production of the work above mentioned, giving first attention to the press, as the type, furniture, ornaments, etc., are in a measure selected to conform to the limitations of work which may be done upon the press. Good work demands a good press; a poor one means that the business is handicapped at the outset by difficulties which more than offset the saving in first cost, and limit both the capacity and quality of the work. On no account buy a small toy press, requiring short type.

In obtaining a press, the opportunities offered by dealers in second hand presses should not be overlooked, but the advice of an experienced pressman

should be secured, if possible, when making the purchase of either an old or a new press, as there are many things entering into the design and operation much can only be learned by long experience, and the novice would be quite likely to select a press poorly suited to his needs. An advertisement in the nearest newspaper of large circulation will often bring a favorable offer from some one having a press for sale. Inquiries can also be made of employees in neighboring printing establishments. In purchasing a second hand press, the wear of shafts and bearings, should be carefully ascertained; if badly worn good work cannot be done upon it. If parts have been repaired, learn if sufficient strength has been secured by the repairs, so that an early break down is not probable. A broken part in a press materially reduces its selling value, even if the break has been well repaired.

If possible, secure a foot power press, the increased speed and convenience of operation, soon returning the extra cost over a hand lever press. With the former, a "throw off" is desirable, this being a lever for throwing off the platen, when desired, so that the type will not come in contact with it. This will be more fully explained when the subject of "Presswork" is reached. The hand lever press does not require a "throw off" the movement of the platen being controlled by the lever. While preference should be given to the foot power press, a wide variety of excellent work can be done with a hand lever press of good design. Whether foot or hand power, it should be self-inking, as hand inking presses require considerable care and skill to secure a proper inking of the type, as well as more time for the work; two operations, that of inking and feeding the paper, being necessary for each impression. For plain card work a hand ink-

ing press will answer, but the beginner will find it a difficult matter to do acceptable work with it.

The size is also important. Presses are designated by the size of the chase, the iron frame which holds the type. Even if only card work is to be done, a chase 5 x 8 inches, inside measurement, is desirable, as 3-4 inch each way is necessary for the "lock up," that is, the fastening quoins, usually metal, holding the type firmly in the chase. A press with a chase 6 x 9 inches costs but little more than the other and will print full size letter heads. Other desirable sizes are 6 x 10 and 7 x 11 inches, the greater capacity being desirable if within the means of the reader. The design and construction of the many good presses sold by dealers will not here be touched upon, these being matters about which the purchaser should consult with an experienced friend. Most printers will gladly give reliable advice upon this subject to a worthy inquirer.

A desirable feature found on most presses now manufactured is that of the regulation of the platen by means of impression screws. Without such screws the "make ready," or preparation of the platen to obtain an even ink impression, is entirely secured by "overlaying" or "under laying," the former being the addition or removal of varying thickness of paper to the platen, and the latter, the addition of paper or thin cardboard strips to such cuts and worn type as may be necessary to raise them to a level with the rest of the type. This work is still necessary, even with a platen fitted with impression screws, as these screws should be adjusted only when absolutely required by extra thin or thick stock, or large uneven "cuts," this being the general term for designating electrotypes, process plates, etc.

HAND - SAWS.

THEIR CONSTRUCTION AND USE.

EXTRACTS FROM "HANDBOOK FOR LUMBERMEN," HENRY DISSTON & SONS.

The demand for an article of instruction on saw filing having been demonstrated to us not only by personal inquiry and letter, but also by the return of fine quality saws, pronounced defective through a lack of knowledge of how to keep them in order, or by the use of extensively advertised so-called saw sets and other tools,—which pull the saw blade apart or so distort it as to render it unfit for use—has led us to compile this information for the enlightenment of the amateur, and the improvement of the expert mechanic.

We will endeavor to give such practical information as to the proper methods of keeping saws in order and of the tools with which to do so, that will overcome the

above-mentioned pitfalls to the proper working of the saw.

The following cuts give the full size of the respective number of teeth and points per inch which they represent. Care should be taken when ordering to specify whether teeth or points per inch are intended, for it will be noticed that in one inch space there is one tooth less than there are points.

PRINCIPLE OF CONSTRUCTION.

The saw is either reciprocating or continuous in action, the first being a flat blade and practically straight edge, making a plane cut, as in hand, mill, jig and sash saws; the latter, either a circular or rotating

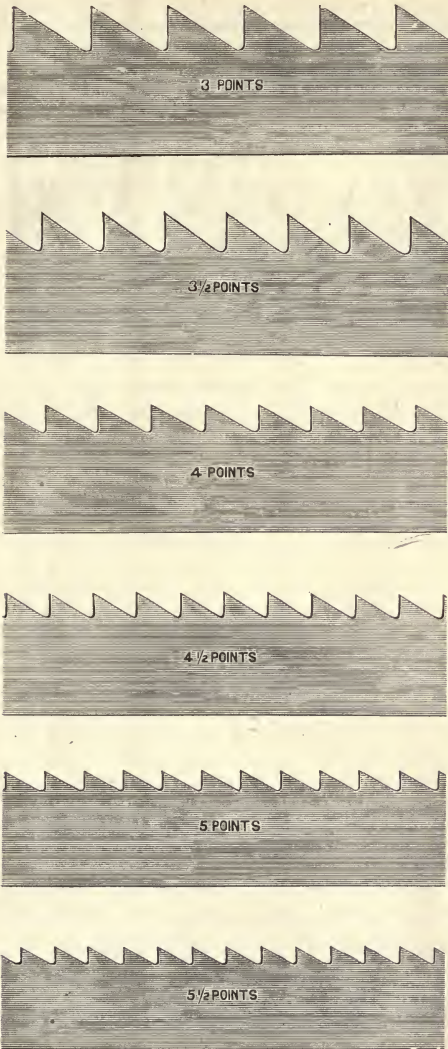

FIG. 1. RIP SAWS.

disc, cutting in a plane at a right angle to its axis, a cylindrical or barrel shape with a convex edge cutting parallel to its axis, or a continuous ribbon or band running on two pulleys making a plain or curved cut with a straight edge parallel to their axis of rotation. Practically speaking, the teeth are a series of knives set on a circular or straight line, each tooth cutting out its

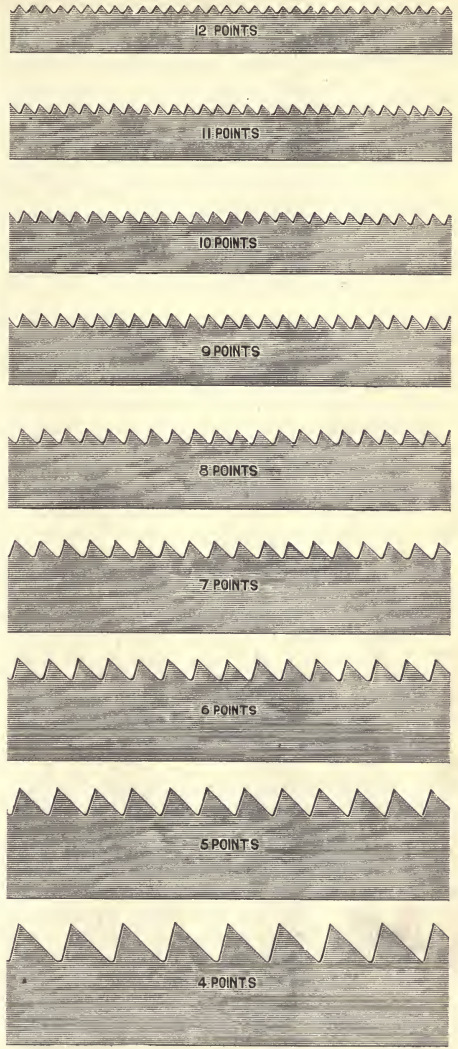

FIG. 2. CROSS-CUT SAWS.

proportion of wood and prevented from cutting more by the teeth on either side of it. Each tooth should cut the same amount and carry out the chip or dust, dropping it below the material being sawed. Different kinds of wood require teeth varying in number, angle or pitch and style of filing.

The perfection of a saw is one that cuts the fastest

and smoothest with the least expenditure of power; to do this, it is evident that each tooth should be so constructed and dressed as to do an equal proportion of the work, for if any of the teeth are out of line or shape, they are not only useless themselves, but a disadvantage to the others. We find many good mechanics who frankly acknowledge that they never could file a saw satisfactorily; the probable reason is that they never studied the principle of the action or working of the tool. There is no reason why any man of ordinary mechanical ability should not be able to file, and keep his saw in order, but like all trades, it requires practice and study of the subject.

The following illustrations and explanations will greatly assist in the selection of a saw and show the best methods of keeping it in order. These should be carefully studied.

A saw tooth has two functions—paring and scraping. A slitting or ripping saw for wood should have its cutting edge at about right angles to the fibre of the wood, severing it in *one* place, the throat of tooth wedging out the piece.

In a cross-cut wood saw, the cutting edge also strikes the fibre at right angles to its length, but severs it on *each side* from the main body before dislodging it.

RIP SAWS.

Fig. 1 is a four-point rip or slitting saw with the rake all in front, where the cutting duty is. This saw should be filed square across, filing one-half the teeth from each side after setting, which will give a slight bevel to the cutting edge of tooth, as it should be for soft wood; for medium hard woods a finer toothed saw with five points to the inch should be used and dressed in the same manner; for the very hardest and toughest cross-grained woods a still finer tooth saw is required, with the teeth filed slightly beveling, as ripping cross-grained stuff partakes a little of the nature of cross-cutting. In all cases where ripping is done, the thrust of the saw should be on an angle of about 45° to the material being cut, as shown in Fig. 2, this makes a shearing cut, an advantage that can be quickly demonstrated with an ordinary pocket knife cutting any piece of wood. For ripping thoroughly dry lumber, it will be found advantageous to use an extra thin back saw which will run without set.

CROSS CUT HAND-SAWS.

In cross-cutting, the fibre of the wood is severed *twice*—on each side of the saw—the thrust dislodging and carrying the dust out.

Fig. 3 is a five-point peg tooth cross-cut saw with the rake on the side. For the same reason that the rip saw has the rake on front of tooth, the cross-cut has it on side, as that is where the cutting duty is. The bevel or fleam to teeth in Fig. 3 is about 45° , while there is no pitch at all; the angle on each side being the same, forms the "peg tooth," which is best adapted to cutting soft, wet and fibrous woods. This style of tooth is principally used in buck-saws.

In all cases, the size and length of teeth depend largely upon the duty required; a long tooth has the demerit of being weak and liable to spring, but the merit of giving a greater clearance to the saw-dust. The throat space in front of each tooth must be large enough to contain the dust of that tooth from one stroke; the greater the feed, the deeper the dust chamber required, or, more teeth.

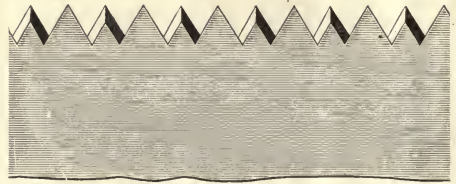

Fig. 3. PEG TOOTH CROSS-CUT SAW.

The first point to be observed in the selection of a saw is to see that it "hangs" right. Grasp it by the handle and hold it in position for working, to see if the handle fits the hand properly. These are points of great importance for comfort and utility. A handle should be symmetrical, and the lines as perfect as any drawing. Handles made of green wood soon shrink and become loose, the screws standing above the wood. An unseasoned handle is liable to warp and throw the saw out of shape. The next thing in order is to try blade by springing it, seeing that it bends regularly and evenly from point to butt in proportion as the width and gauge of the saw varies. If the blade is too heavy in comparison to the teeth, the saw will never give satisfaction, because it will require more labor to use it; the thinner you can get a stiff saw the better; it makes less kerf and takes less muscle to drive it. This principle applies to the well-ground saw. There is less friction on a narrow true saw than on a wide one; you will get a smaller portion of blade, but you will save much unnecessary labor at a very little loss of the width.

See that it is well set and sharpened, and has a good crowning breast; place it at a distance from you and get a proper light on it, by which you can see if there is any imperfection in grinding or hammering. We should invariably make a cut before purchasing a saw, even if we had to carry a board to the hardware store. We set our saws on a stake or small anvil with a hammer; a highly tempered saw takes three or four blows, as it is apt to break by attempting to set it with but one blow. This is a severe test, and no tooth ought to break afterwards in setting, nor will it, if the mechanic adopts the proper method. The saw that is easily filed and set is easily made dull. We have frequent complaints about hard saws, though they are not as hard as we would make them if we dared; but we shall never be able to introduce a harder saw until the mechanic is educated to a more correct method of setting it. As a rule, saws are given more set than is neces-

sary, and if more attention was paid to keeping points well sharpened, any well-made saw would run with very little set, and there would be fewer broken ones. The principal trouble is that too many try to get part of the set out of the body of the plate, whereas the

whole of the set should be on the teeth. Setting below the root of the tooth distorts and strains the saw-plate, which may cause a full tempered cast-steel blade to crack, and eventually break at this spot; and it is always an injury to the saw; even if it does not crack.

JUNIOR DEPARTMENT

For the Instruction and Information of Younger Readers.

MODEL "RELIANCE".

This model is designed as a companion to the Shamrock III model in the last issue. The general directions for making the latter model apply to this one equally well. The dimensions of Fig. 1 are as follows:

Length on L. W. L.	30"
Overhang forward	9 1-4"
" aft	7 5-8"
Height of Sheer at stem	2 7-8"
" " " , taf.all	2"
" " " , lowest point	1 5-8"
Greatest width on deck	9"
Width at taf rail	2 1-2"
Greatest draft	6 1-4"

If the model is built for sailing it should be hollowed out to about 1-2" in thickness. The neatest way to fit the board for the deck, is to cut it about 1-4" smaller all around than the outline of the boat, then with a sharp knife mark around it and cut down with a chisel deep enough to allow the board to set down flush with the outside edge of the deck. This board is about 1-8" thick.

The amount of ballast which the boat will carry cannot be determined until the hull is hollowed out. It may then be floated in water, and sufficient lead put on board to bring her nearly down to the waterline, this amount is then melted and moulded into the keel, which is fastened on with long screws, or small brass bolts. A small amount must be left to fasten inside to bring her to just the proper trim.

The lines as shown are rather fuller than in the actual boat, but this is necessary for a sailing model to enable her to carry her sail successfully. The spars are of straight grained spruce.

The sail plan as shown in Fig. 2 is drawn to scale and the lengths of the several lines can be scaled directly. The mast is placed 18" back from the stem; it is 45" long above the deck, 3-4" diameter from deck to above the gaff, tapering to 1-4" at top. The boom is about 33" long, 3-8" diameter at each end, 5-8" diameter at the main sheet fastening, tapering towards the ends. The gaff is 20" long, and about 1-2" thick, with slightly oval shape; it should be fitted with a pair of jaws to fit against the mast, either of

wood, or sheet brass bent to shape and tacked on. The bowsprit is 10" long outboard; and about, 5-8" diameter, tapering to 3-8" at the outer end. It is fastened to the deck by small straps of brass bent over it and screwed to the deck.

It is recommended that for the rigging fine brass wire be used. For the mast there should be three side stays, two leading from the point of attachment of the fore stay, and one from the topmast head; leading down to chain plates about 3-4" apart, which are made of narrow brass fastened to the hull with brass nails or screws. A very neat way of making these stays fast is to turn a loop about 1-8" diameter, so that it stands about 1-2" above the chain plates, then several strands of silk line are rove through both, making a good finish. At the top a loop is turned to fit over the mast and bear upon the head of a small screw or nail, to prevent slipping down. The forward stays are fastened by loops in the same manner, and are adjusted to the proper length and the slack taken out by lightening the side stays. The topmast stay leads out over a pair of spreaders about 10" long, which can be made by soldering a piece of wire on each side of a band and bringing the ends together and forming an eye for the stay, as in Fig. 3.

The bobstay is made of rather heavier wire and may well be double; its lower end is fastened to a brass strap. The bowsprit also has a side stay on each side, kept apart by a spreader of wire passing through the hull just aft of the stem. An eye in the end of the boom takes a corresponding eye in the mast and allows the boom to swing. To attach the main sheet, a small band of wire may be made around the boom.

The rudder has a metal stock 1-8" diameter, passing through a tube to make it water tight. It must be an easy fit and turn readily. The steering gear is as shown in Fig. 3. The double ended tiller is on the rudder head, pointing fore and aft; the aftermost eye takes the main sheet and the forward eye takes one end of a spiral spring. To the other end of the spring is attached the screw, about 1-8" diameter, which passes through the stop on the deck, and has a thumb nut by which the spring is extended more or less. In sailing, the rudder will be turned an amount varying with the pressure of the wind, and the amount of turn

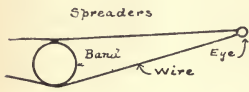

FIG. 3.

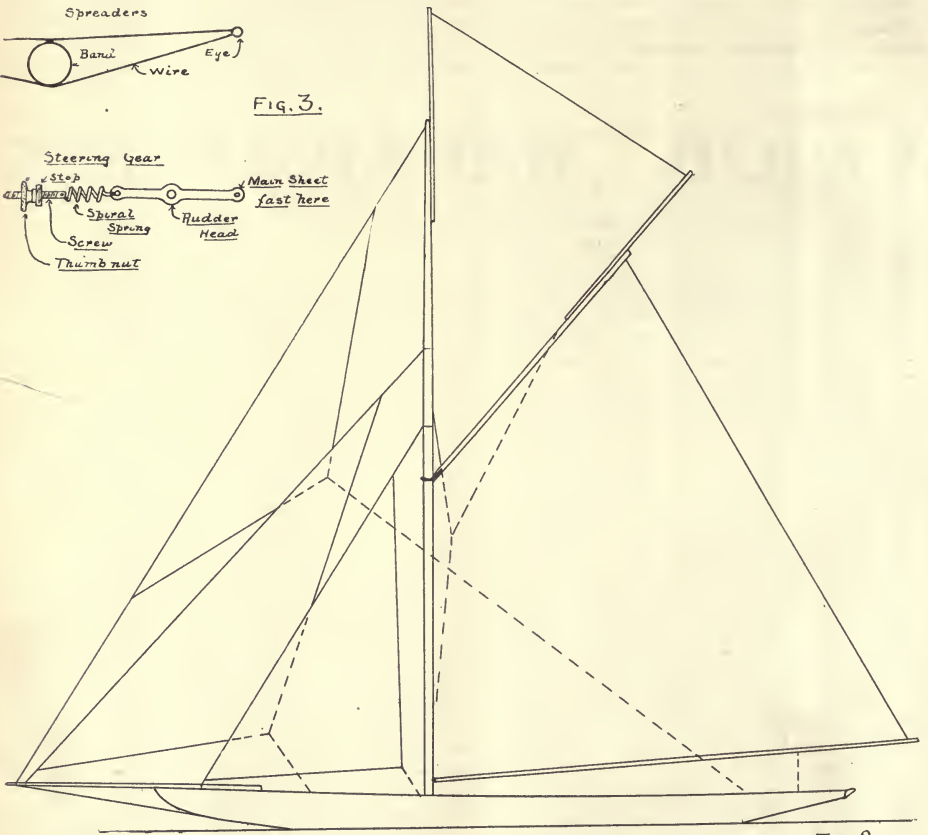
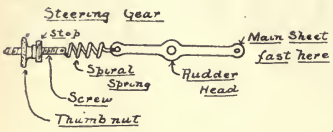

FIG 2.

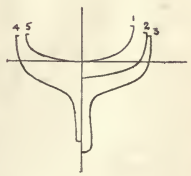
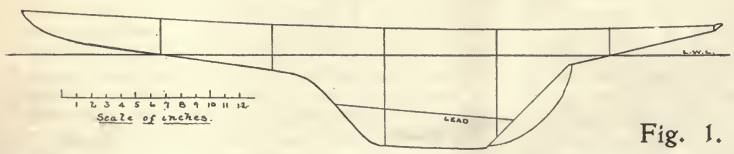
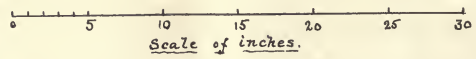

Fig. 1.

is regulated by the thumb nut. Definite dimensions cannot be given for these parts, as they depend upon the peculiarities of each boat, and can only be found by trial. This arrangement works very nicely when correctly adjusted.

The sails are of light cotton cloth, or still better, of linen. The after edges of mainsail should be selvage edges and the other edges of all the sails should be neatly hemmed. The mainsail has rings which slide on the mast and is laced to boom and gaff. The stay- and jib are laced to the stays, and held up by halliards, while the club topsail and jib topsail are removable. The halliards for all the sails are fastened to small wire rings bent around the mast.

The mainsail will, of course adjust itself from side to side, but the head sails must be shifted when tacking, so that a sheet is necessary on each side, leading around the fore stays, the leeward one being tightened. The sheets may be of small woven fish line and should lead through small staples driven into the deck far enough to cause an easy friction on the line and hold it at any point.

The rigging as outlined is for a model for sailing; if one is wanted for exhibition it can be made more ornamental, with blocks more pretentious rigging according to the desires and skill of the builder.

MARBLE COASTER.

KENNETH G. ROBINSON.

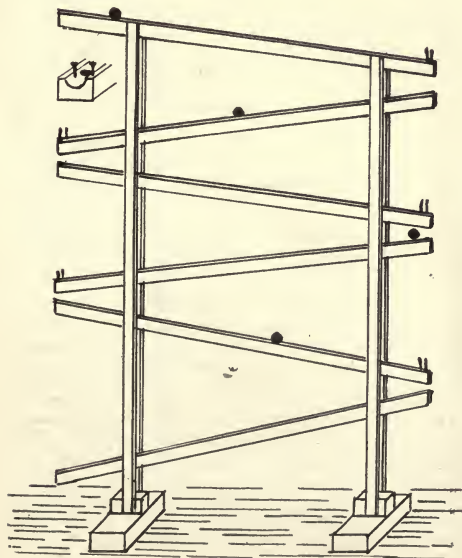

The reader of this department who may have a youthful brother or sister for whom he would construct a pleasing toy, will find this marble coaster well worth the making. The six run-ways are made of straight grained pieces of wood 18'' long, 1 1-2'' wide, and 7-8'' thick. A grooved is cut along the centre with a 3-4'' half round plane or gouge, and a 1'' hole bored 1-2'' from one end and at a slight angle so that the hole will be vertical when in position.

The upright pieces holding the runs are 1'' wide and 1-2'' thick, the longer ones being 22'' and the others 20'' long. These are nailed to each side of the runs with short wire nails, the bottom ends being nailed to small blocks 3'' x 1 1-2'' which in turn are nailed to larger blocks 5'' x 2'' x 7-8'' set crosswise as shown to hold the roller firmly upright. Nails are driven into the ends of each run just below the holes to stop the marbles, and cause them to drop through the holes into the run below. A small box at the end of the lower run catches them at that point. Small children will find much pleasure in placing the marbles in the top run and watching them roll back and forth to the bottom.

HANDY RECEIPTS.

HOUSEHOLD PASTE.

A strong, clean, lasting paste which will not sour, may be made in the following manner:— Into a double boiler or other suitable vessel, put three pints of flour, gradually adding about one quart of cold water, to make it the consistency of thick cream. Beat with an egg beater to free from lumps. Add one teaspoonful of powdered resin; beat again thoroughly. Cook over boiling water, having added one cup of boiling water to the mixture, stir constantly until thick. After cooling add one-fourth teaspoonful oil of cloves. Store in glass jars, and thin with warm water as needed for use. This will make about three pints of thick paste which will keep indefinitely.

INK FOR RUBBER STAMPS.

The vehicle used in the preparation of inks for rubber stamps is glycerine, a non-drying substance, so that pads charged with the color may remain indefinitely. Such ink, of course, is not as desirable as one that would thoroughly dry on exposure; but the latter, regular printing ink, requires a kind of handling too troublesome for most users of stamps. Aline colors are usually employed as the tinting agents. The following is a typical formula, the product being a black ink. Nigrosin 3 parts, water 15 parts, alcohol 15 parts, glycerine 70 parts. Dissolve the nigrosin in the alcohol, add the glycerine previously mixed with water, and rub well together. *Druggist' Circular and Chemist' Gazette.*

SHOE BLACKING.

A good liquid blacking may be made by mixing 3 lb. of lampblack with 1 quart stale ale, and 1-2 pint sweet oil, adding thereto 1 oz. molasses, 1-4 oz green cop-pers, and 1-4" oz. logwood extract. This blacking polishes easily and well.

STRONG MUCILAGE.

Equal parts of powdered gum tragacanth and gum arabic, moistened with diluted acetic acid, or if the color is not of importance with ordinary vinegar, will produce a strong mucilage which will keep well.

CORRESPONDENCE.

Our readers are invited to contribute to this department, but no responsibility is assumed for the opinions expressed in these communications.

Illustrate the subject when possible by a drawing or photograph with dimensions.

Letters for this department should be addressed to editor of AMATEUR WORK, 77 Kilby St. Boston. They should be plainly written on only one side of the paper, with a top margin of one inch and side margins of one-half inch.

The name and address of the writer must be given, but will not be used, if so requested.

Enclose stamps, if direct answer is desired.

In referring to other letters, give the number of the letter referred to, and the date published.

Readers who desire to purchase articles not advertised in our columns will be furnished the addresses of dealers or manufacturers, if stamp is enclosed with request.

No. 62. KALAMAZOO, MICH. Sept. 26, '03.

There is one point about the closed-circuit cell described in the July, '03, number, which bothers me. When the Caustic Potash solution is put into the inside of the wire gauge cylinder it will leak through the gauge and mix with the filings. Is this detrimental to the cell or not?

R. H. W.

It is necessary that the electrolyte Caustic Potash solution reach the iron filings, otherwise there would be but little action.

No. 63. EVANSTON, ILL. Oct. 8, 1903.

I am building a canoe after the model described in the April number of AMATEUR WORK, and would like information on a point which does not seem quite clear to me. Are the longitudinal strips to which the ribs are bent, intended to be removed before putting on the sheathing?

P. B.

The long ribbands are to be removed before putting on the sheathing of the canoe. They are used simply as guides for setting up the ribs to the correct lines, this being an easy yet satisfactory way for doing this part of the work.

No. 64. MONTEREY, CAL. Oct. 12, 1903.

Will you please tell me of a book giving the best instruction on the operation and construction of Gas or Gasoline engines. And also please state what is the best book on the Steam engine for a beginner.

C. F.

A good book on the Steam engine is by Ripper, Gas and Gasoline Engines, Roberts Gas Engine Handbook. A series of articles on the subject of "Gas Engines" will begin in the next issue of this magazine.

No. 65.

PITTSFIELD, MASS. Oct. 14, '03.

I have a few questions I wish you would be kind enough to answer in your correspondence column. I have made the Wims-hurst machine described in your paper a year ago last spring, and think it a success. Very often I draw a spark almost five inches long. I think I will make the large Wimsburst machine described some time ago and the mercury air pump described a few months ago if you think I could make a X-ray outfit? A. Would the expense be great besides the air-pump and large static machine? B. If possible could you publish an article on the X-Rays. C. What is the amperage of the bichromate plun-ge battery described in No. 7 of Vol II with the cells in series if the voltage is 12.5. D How long will the electrolyte last? E Will it run the motor described in No. 5 of Vol. I at its full capacity?

I also got the idea of a gramophone from your paper, I did not follow the exact lines on the sound-box or case but the clearness and volume of sound is about as good as I have ever heard on the best of machines.

W. G.

A. The question is not very explicit. The expense of an X-ray outfit, except the tube, is small.

B. An article on X-ray work will be published in the near future.

C. 4.2 amperes.

D. The electrolyte should last at least 100 ampere hours on closed circuit, but depends to a considerable extent upon the quality of the materials used in its construction.

4. This battery is more than sufficient to run the motor men-tioned; one of three cells being quite adequate.

No. 66

MINCO, I. T. Oct. 18, '03.

A. I wish to know why a gravity battery will not run an elec-tric motor? B. Can you tell me of any book on electrical con-struction, the price, and where it can be purchased.

M. B. W.

A. A gravity battery will run a motor if a sufficient number of cells are employed. The chief difficulty with this type of cell is the high internal resistance, and since they have an E.M.F. of only 1 volt, the amount of current is necessarily very small from one cell. A battery of 10 of these cells should be sufficient to supply the necessary current for operating small motors. Their chief advantage lies in their constancy.

B. It will be necessary to know more definitely the kind of constructive electrical work in which you are interested, before this question can be answered.

No. 67.

LYNN, MASS. Oct. 3, 1903.

I would like to make a jump spark coil for a 3 H. P. engine. Can you give me information relating to the winding of the secondary coil.

J. M. H.

A description of a spark coil for engines of about the size you mention is in preparation and will be published, if ready, in the next number of this magazine.

TRADE NOTES

In response to the frequent demands for Yankee Screw Drivers put up in substantial and well finished boxes to be used by amateur mechanics who desire to keep their tools in fine order, and gentlemen who appreciate handsome tools, the North Bros. Mfg. Co. of Philadelphia, Pa., have prepared such a set in a box which is very substantially made of oak and handsomely finished. The box contains one each of No. 30 spiral ratchet screw driver with eight drill points, a counter-sink to use in same tool, No. 11 ratchet screw driver with 6 inch blade, No. 15 ratchet screw driver with finger turn on 3 inch blade. The combination in this set covers the tools most in demand. They are easily removed from the box and held firmly in place when not in use. A descriptive circular together with prices will be sent upon application to the above company.

AMATEUR WORK

A MONTHLY MAGAZINE OF THE USEFUL ARTS AND SCIENCES

Vol. III. No. 2.

BOSTON, DECEMBER, 1903.

One Dollar a Year.

GAS ENGINE SPARK COILS.

ALBERT GRAHAM.

I. Coils for "Make and Break" Type of Igniters.

Two methods of electric ignition are in general use to explode the compressed charge behind the piston of a gas or gasoline engine. These are commonly called the "make and break" spark method and the "jump-spark" method. Of these

taneous adjustment, known as "timing," by means of which the explosion is made to occur at different points of the stroke. The principle difficulty with the former method is the rapid deterioration of the sparking points due to the

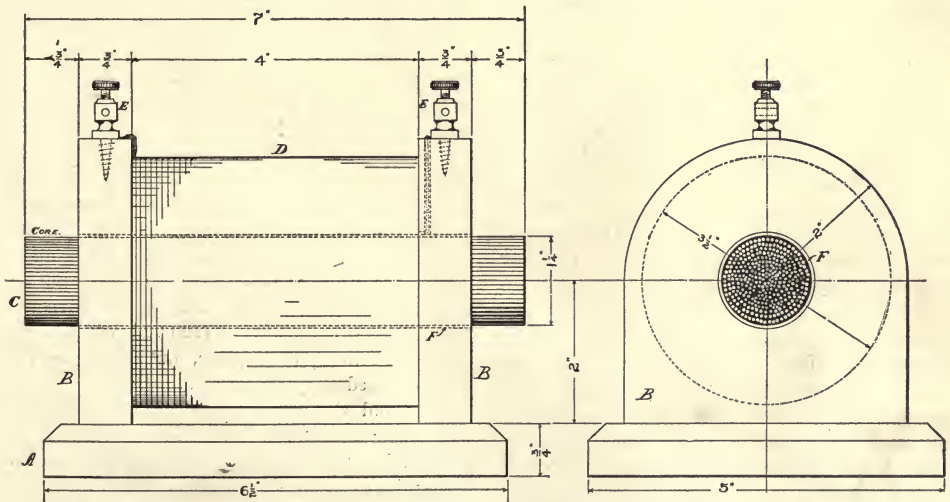

two perhaps the "make and break" contact method will give the most general satisfaction, although to make a positive assertion on this point is to assume a great deal, since the jump-spark method allows of great latitude in instan-

ting caused by the spark, while on the other hand the spark-plug used in the jump-spark method occasionally becomes covered with soot (unburned carbon deposited after the explosion and caused by insufficient air being mixed with

the gas or gasoline vapor, thus preventing complete combustion) which short circuits the current, on the other hand the oil used in lubricating the cylinder is sometimes deposited on the sparking terminals of the plug and burned on as a glaze by the heat. This forms an effectual insulating medium through which the spark may be unable to penetrate owing to the increased resistance.

In order that a spark may pass between any terminals separated by an air gap, it is necessary that the tension of the current be raised to such a point that the resistance of the intervening layer of air will be overcome, and the current passing across will heat the suspended matter into a highly incandescent state which gives rise to the spark.

If we join to the terminals of a cell two wires and complete the circuit by joining the free ends, we will notice that a small spark is formed when the ends are suddenly separated. Suppose we now include in the circuit an electric bell, when the bell is ringing sparks of considerably larger size will be seen at the vibrating armature spring contact, even with the same cell as before. Now this increase in the size of the spark is caused by the effect of the magnets in the following manner.

When the bell is in a passive state and the current is first turned on by pressing a button or other means of closing the circuit, the magnets do not instantly acquire their full strength, but require a very short interval of time to "build up." When this state is reached they attract the armature, thus breaking the circuit. But the lines of magnetic force which are at this time coursing through the magnet cores and armature do not cease immediately, and it is the cutting of these lines of force by the coiled conductors (wire) as they fall from their maximum value to zero that generates sufficient tension to make the spark jump the gap between the terminals. It is, in fact, as if the current possessed inertia which required the application of an external force to bring it to rest.

Now this is exactly why a spark coil is provided for a gas engine with contact points that are suddenly separated. It consists of a core of soft iron wires closely bound together and surrounded by a coil of insulated magnet wire of many turns. The core is built up of small wires because it

makes a much stronger magnet, due to various reasons that need not be discussed at present.

To make this core, it will require $2\frac{1}{2}$ lbs. of No. 14 soft iron wire, cut into lengths of 7". About 250 pieces will be required. When all are cut, bundle them together as closely as possible and wrap firmly with small steel or iron wire. Lay a piece of thin sheet iron over a good bed of coals in a stove and upon this place the bundle, leaving it there until the entire mass is brought to an even cherry red heat, not too bright. Then by means of a pair of tongs place the red hot bundle just on the top of the fire brick where it will cool very slowly, pushing it back further and further from the coal pit at intervals of about half an hour. This will serve to thoroughly anneal the wires and give them a high permeability.

After they are cooled off at the back of the stove, bring them into the air and allow to cool to the temperature of the room. Then bind the ends firmly so that the first binding wire may be removed. Now begin to wrap the bundle with a strip of foolscap paper cut into strips $5\frac{1}{2}$ " wide, cementing it in place with shellac. When a layer about $\frac{1}{8}$ " is laid on, tie a thread around it to keep it from unrolling and bake in a warm oven until perfectly hard. This paper tube will serve to keep the wires in place but the binding wires now on the ends must not be removed entirely until the coil is finished.

Cut out the base from cherry or some other hard wood, making the coil ends *B-B* of the same stock. Bore a hole in each end as shown so that it will just go over the paper tube. Force the ends on and secure by a little shellac, after making both bases parallel so that they will each lie flat on the base *A*. The binding wires on the ends may be temporarily removed while these ends are being put in place, but should be replaced immediately thereafter.

Now find the centre of the iron wire core *C* with a pair of dividers, and drill a small hole in each end, countersinking for the lathe centers. Swing the spool on the centres and drive either by a clamp-dog or a piece of wire wrapped around the core end and then fastened to the face plate. The binding wires on the core ends will prevent the pressure of the tail centre spreading the wire.

One of the spool ends has a vertical hole drilled

from the top to the center which accommodates the end of the inside layer of wire. Pass the wire through this hole before beginning to wind leaving enough protruding to attach to the binding post *E*. Wind the space between the ends full of No. 18 single cotton covered magnet wire, which will require about 6 $\frac{1}{4}$ " pounds. Secure the end of the last layer to the other binding post. These binding posts should have a wood-screw end which can readily be screwed into place and exert a good pressure on the bared end of the wire beneath them, thus preserving a good contact. Give the last layer two or three good coats of shellac varnish, allowing each to dry in an oven before applying the next. This will serve to exclude moisture from the coils. A layer of cord may be wrapped on outside of this if desired, which, when stained black with india ink or shoe-polish, dried, and polished with wax makes a very handsome finish.

Mount the spool on the base by four screws passing through it and finish by giving two coats of varnish. This coil should be connected in series between the battery and the sparking device of the engine. It is very strong and will

give a good fat spark if the connections are well made. A word of advice to those fitting out gasoline or gas engines with a make and break contact ignitor. Do not attach one terminal to one end of the spark plug and the other to some remote part of the engine frame where the current will have all the extra resistance of the metal, frame joints and dirty, oil-begrimed bearings of the other vibrating contact point to pass through. Drill a hole into the end of the moving or oscillating pin and tap it so that it will take a binding post. Then make your other connection to this post, wrapping the wire once or twice around the shaft or even the binding post itself, tying it there with thread or another wire. This will allow the wire to bend with the movement of the shaft and not be broken off. The amateur will find that this method will give him less trouble than the ordinary method, his spark will be better for the lower resistance, and with proper care the connecting wire need not be broken by the vibrations. This one point in particular is where fully half of the present day engine troubles lurk.

The jump-spark coil will be described in the next number of Amateur Work.

MICROSCOPY FOR AMATEURS.

S. E. DOWDY. M. P. S.

Leaving this brief outline of the instrument's history, we will presume the reader unacquainted with microscopy and on the lookout for a microscope, and trust that the following suggestions as to the selection of a suitable one may give the chooser some idea of what to expect and what to avoid.

In the first place, the beginner should clearly bear in mind that the real benefit to himself and science derived from his taking up microscopy as a hobby will depend more on his own efforts than on the cost of the instrument. Leenwenhoek, with his crude single lenses fastened in metal plates, made observations and recorded details which the modern scientist with his carefully corrected compound lenses cannot dispute or even in some cases enhance; and this is mentioned not

to disparage modern instruments or methods, but simply to point out that care and patience can accomplish much, even when handicapped with inferior tools.

The choice of an instrument must necessarily be governed by the length of the purchaser's purse; but the average cost of a good working microscope for students' use may be taken as about \$25. They can be obtained for as low as \$10, or even less, second-hand. The beginner, however, is strongly advised not to purchase a second-hand instrument, unless it is a recent model by a well known maker, as unless he can obtain a friend's advice on the subject he may find himself burdened with an old-fashioned type of stand, with obsolete fittings and adjustment.

So rapid have been the advances and improve-

ments in the cheaper forms of microscope of late years that the better plan, if unacquainted with the subject, is for the beginner to put himself entirely into the hands of a good dealer, stating what he feels disposed to invest in the purchase of one, and relying on the dealer's honesty to supply him to the best of his ability.

In purchasing either a new or second-hand instrument, above all things do not be carried away by the glamor of lacquer and highly polished metal; in fact, don't judge a microscope by its appearance, only from its performance. Lacquer cost little, careful workmanship in fitting and adjusting a lot, and the fine qualities are not always found in the same microscope. The general appearance of the microscope is, from its frequent appearance in optician's windows and similar situations, tolerably familiar as far as its external features are concerned, so that a description is not necessary. Though similar in their general appearance, microscopes may really be divided into three classes. There is, for instance, the full sized instrument, replete with every convenience that experience can suggest and wealth and skill provide. Then, again, there is the smaller edition, shorn of most of the mechanical conveniences found on the larger stands. It is with this class of microscope, generally known as the Student's, that we have to deal. Lastly, there are those microscopes which to all intents and purposes are merely toys, useless for either recreation or study. I am glad to say they are mostly importations from the Continent, their low cost being only equalled by their inferior performance. These must not be confounded with the products of such houses as Zeiss, Leitz, etc., whose work is certainly equal to some of our best opticians, though their models may not be quite so well designed. We must not forget, too, that we are indebted largely to them for improvements in the cheaper lenses now on the market. Large instruments are not suitable, and are too costly for the average amateur, their chief advantage being that they will give a larger field of view than the students' instrument, and this is not always the advantage that might be expected.

Before actually purchasing the microscope, it would be well to bear in mind some of the characteristics of a good instrument for student's use. It should be simple in construction, com-

pact, and sufficiently heavy to insure the necessary stability. Its adjustment must work smoothly and be conveniently situated both for working purposes and for repairing if necessary. Its fittings must be of standard size, and the stand, as the instrument minus its lens is termed, should be capable of taking the accessory apparatus required from time to time in microscopical work. Providing its lenses are up to the mark, an instrument having the above qualifications can be relied upon for all ordinary purposes. Before proceeding to test its adjustments, it will be as well to briefly indicate the parts which go to make up a complete stand. First of all comes the *Base*. This will probably be either the Continental form, which consists of a heavy horsehoe-shaped piece of metal surmounted by a thick brass pillar, on which the rest of the instrument is joined, or else the English form of foot, which is a tripod, the spread given to the feet insuring the stability, which in the Continental form is mainly secured by the weight of the horsehoe. The chief advantage of the Continental form is its compactness; but if desirous of taking up photography or drawing with the camera lucida, the student is advised to choose the tripod base, the only objection to it being that an instrument fitted with it requires a rather larger cabinet. Most microscope bases are made after these two models, or slight modifications of them.

Next comes the *Mirror*. This should be double, plane on one side and slightly concave on the other, and so fitted that it can be slid nearer and away from the object. Usually it is mounted on a swinging arm, so that oblique illumination may be obtained, as the fine details of an object may sometimes be made out when direct axial light fails to reveal them, if the illuminating pencil of rays of light be sufficiently oblique.

We now come to a most important part of the stand — viz, the *Substage Condenser*. This may or may not be present, it all depends upon the original cost of the instrument. In its simplest form it consists of two lenses, mounted in a short fitting. The lower lens is rather large, double convex, and serves to collect divergent rays from the mirror and transmit them through the upper lens, which is smaller and plano-convex, with the plane surface next the microscope stage. The chief purpose of the substage condenser is to pro-

vide brilliant illumination of an object when using high-power objectives. Incidentally, the image is improved by the illuminating rays being brought to a focus and concentrated on the object, the resultant image being more sharply defined than if light from the mirror alone without any condensing system was being employed. If purchasing a new stand, insist on having one either provided with a substage condenser, or else a fitting capable of taking one at some future time, as they may be purchased separately at any time. If this is out of the question fit in an improvised substitute, as a microscope nowadays can hardly be called such if unprovided with such a necessary adjunct.

The Stage, as the flat plate on which the slides are placed for examination, is termed, will now require a short comment. In students' microscopes it is simply a metal plate, with either a circular or horseshoe-shaped opening, on each side of which is a spring clip for holding down the slide. Better class microscopes have mechanical stages where motion is imparted by rotating milled heads, but as these require very skilled labor in fitting and adjusting, they cannot very well be added to a cheap instrument. The addition of a sliding bar to the ordinary stage is an improvement, and can be obtained to fit nearly any make of stand. If the microscope is not fitted with a substage condenser, it should have a metal plate, furnished with circular apertures of varying diameters, to revolve just under the stage aperture. This arrangement is called the diaphragm, and is used to cut down the amount of light thrown up by the mirror. Very transparent objects with delicate detail are quite obscured if too much light is being used, and this is where the diaphragm is useful.

The *Body-tube* next requires a little description. Two lengths are adopted nowadays by the makers; viz., 6 inches for students' instruments, 10 inches for their larger stands. It is important to note the difference because objectives are corrected nowadays for either one tube length or the other, and it is necessary, if the highest excellent of definition be desired, that a lens should be used on that particular tube length, for which it was originally corrected and intended. If possible, get an instrument the body-tube of which is fitted with a draw-tube; a short length

of tubing, the upper end carrying the eyepiece, and sliding up or down in the main tube. The draw tube is a most useful edition to a microscope as increased magnification is obtained by its use, and if a student's pattern instrument, objectives for both 6 in. and 10 in tube lengths can be used on the same stand by simply closing up or pulling out draw-tube. The diameter of the main tube may also vary. Student's stands take an eye piece of about .92 in. diameter, the large English stands 1.07 in. Unfortunately, all eye pieces are not made to exactly the same gauge, as in the case with objectives mounts, so that it is as well to purchase the eyepieces from the same maker who supplied the stand.

Focussing Adjustments will now claim our attention. These, as a rule, are two in number, and are known as the coarse and fine adjustments. The former, as its name implies, is for the purpose of obtaining a rough or approximate focus, the latter for getting the correct adjustment necessary to obtain a sharp picture of the object. Coarse focussing may be accomplished by either sliding the body-tube up and down in a cloth-lined collar, this method being adopted in the cheapest stands, or a preferable method being that where a rack and pinion adjustment is substituted, whereby a more delicate motion may be imparted to the tube. It is, however, well worth the extra expense to have the rack and pinion adjustment, which if good, will enable the student to do all his focussing, except when using his highest power lens. The fine adjustment, by the aid of which an almost inappreciable movement may be imparted to the optical system in the microscope, is one of its most indispensable adjuncts. High-power work would be quite impossible without its help, so sensitive are modern high-magnifying objectives to the slightest alteration of their distance from an object. The necessary motion is imparted by rotating a milled head, which in its turn actuates a lever or rotates a screw, different makers adopting different methods to accomplish the same end. As it is important that both coarse and fine adjustments should be of first-class workmanship, their behavior will be noticed when we are testing the lenses supplied with the microscope.

English Mechanic.

CONTINUED IN THE JANUARY NUMBER.

JUDGMENT IN MOUNTING PRINTS.

FRANCOIS VOITIER.

A chain is as strong as its weakest link, no stronger. One defective and eleven perfect links form a chain of no greater resisting qualities than should the entire twelve be imperfect. Every link demands equal care and attention in its manufacture, each contributes its share towards the perfection and usefulness of the whole.

Finished photographs can well be likened unto a chain, the links being designated as exposure, development, fixation, printing, trimming, mounting and framing. None of these several processes can be neglected without detriment to the perfection of the completed product, indifference or carelessness in the moulding of any one link in the photographic chain will not fail to detract from the beauty of the picture in toto.

These are facts, but I hardly think their full significance is appreciated by a good many amateur workers. After exercising reasonable diligence in taking care of the exposure and development of a plate or film and taking off a print therefrom, is it not true that the important requirements in the making of a picture are considered as having been complied with, little (if any) attention being paid to the balance of the links in the belief that they occupy a place of secondary importance? The link "mounting," is it not regarded as having little bearing upon the beauty and strength of the finished picture? Both these queries demand an affirmative answer. Let me assure you that tens of thousands of good prints are annually ruined by injudicious mounting; further, that it is well within the range of possibility to greatly improve an indifferent print (sometimes a really bad one) by keen discrimination in the use of the trimming knife and the selection of the mount. Such, in a few words, is the importance of these links.

The purpose of mounting is to give a picture a "finish," accentuate any good points it may have and so enhance its beauty and value. Unless the mount does this, nothing is gained, in truth, very much is lost, and it would have been far better to have left the photograph in an unmounted state.

Any mount is unsuitable which attracts more attention than does the picture itself. The picture must ever remain the centre of interest and a card of such color, shape, design or size as completely conserves this end is the only and proper one to use. Except by the advanced artist-worker, double mounting, that is a card pasted on a card, is rarely successful when two or more different colors are to be introduced. The practice should certainly not be attempted by the beginner. It is a sign of weakness either to mount a picture in a certain way for no other reason than that someone else has done it, or to mount in a certain way for no other reason than to be different from anybody else. Either of these methods, however, is admissible if carried out in the proper spirit, which might be described as the keeping in mind of the object as a sole and only guide. The bizarre is invariably out of place mainly because the motive which prompts it is not good. Eccentricity is not art, neither is art eccentricity.

The simplest, best and most comprehensive rule to remember in connection with mounting is the one whose key note is harmony. Every photograph has a dominating tint of color, and a continuation of this master tone in the mount will result in a effect both pleasing and artistic. In this way the mount is made to appear as part and parcel of the picture rather than to be intent on stirring up strife one against the other. Combinations whose elements are in a state of civil war are an offense to the eye for the beautiful, the harmonious and the artistic.

Carbon black and the various shades of gray lend themselves admirably to any of the black and white papers, bromide, gaslight and platinum. Green-black and brown-black mounts are useful for prints where the blacks are impure, as is often the case. This degrading of the blacks may either be intentional or purely an accident. Pigment and gum tones call for cards of more positive colors. It would be useless to attempt an enumeration of suitable mounts corresponding to all the tones obtainable in a print, their name is

legion. In any event, to do this would simply put you in a position akin to that of an automaton powerless to follow a course other than that prescribed by a complicated system of internal mechanism.

When all is said, though, the selection of mounts for our pictures is a matter which rests largely with the taste and judgment of the indi-

vidual; but it would seem to me that the individuality reflected in some of the color combinations that have come to my notice is far too immature and insincere to be identified with any thoughtful and artistic worker. A "personal element" of this description should be found wandering around in search of an owner with no claimants in sight.

Camera and Dark Room.

GAMES FOR CHRISTMAS.

JOHN F. ADAMS.

The approach of Christmas, and the accompanying discussion relative to presents for boys, recalls the making of a few games which would be particularly suitable for presents, are easily made at small expense, and would afford much enjoyment to both young and old, so here they are:—

CARROM BOWLING ALLEY.

A particularly desirable feature of this alley is, that the pins and shooting point are both at the same end of the board, thus avoiding the necessity of constantly moving to the other end to set up the pins and recover the balls. For that reason it is attractive to a single player.

The bottom *A*, of white-wood is 48" long, 15" wide, and $\frac{3}{4}$ " thick and should be planed on a surfacing planer to ensure that all wind or uneven places are taken off. Four oak or maple cleats 14" long, 4" wide and $\frac{1}{8}$ " thick, are then screwed across the under side to keep the surface of this board perfectly true, one 2" from one end, one 6" from the other end, and the two others equally spaced between or about 11" apart. The bottom board is then cut out at the end on the end *C* to form a pocket by sawing off a piece 5" with the length and $12\frac{1}{4}$ " across, leaving a projection 3" wide and 5" long. Save the piece cut off to use for the bottom of the pocket. Two side pieces *B* 49 $\frac{1}{2}$ " long, 3 $\frac{3}{4}$ " wide and $\frac{3}{4}$ " thick and two end pieces *C* and *C'*, 16 $\frac{1}{2}$ " long, *C* 3 $\frac{3}{4}$ " wide and *C* 8 $\frac{1}{2}$ " wide and $\frac{3}{4}$ " thick, are then firmly screwed to the sides and ends, the joints being mitred. The wider end piece *C* is for the end with the pocket.

A piece *D* 12" long, 4 $\frac{3}{4}$ " wide and $\frac{3}{4}$ " thick is then screwed to the inner cross edge of the pocket, the edge being just flush with the bottom board.

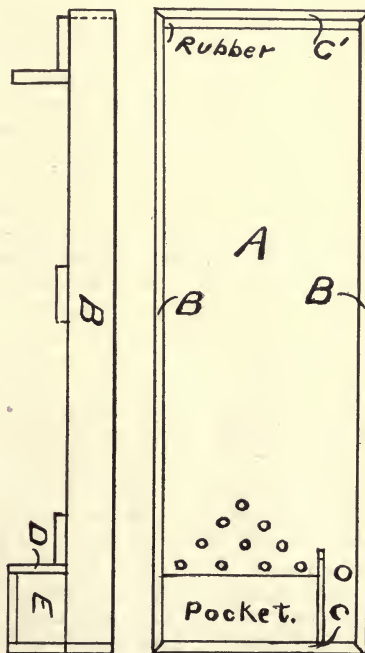

Two side pieces *E*, the outer one 6 $\frac{1}{2}$ " long, and the inner one 5 $\frac{3}{4}$ " long, 4 $\frac{3}{4}$ " wide and $\frac{3}{4}$ " thick, are then fitted to the sides of the pocket. The outer piece has mitred corner at the joint with *C*, but laps over on piece *D*. The inner one laps

on *D* and is fastened to *C* and *A* by screws put through from the outside, the heads of all screws being deeply countersunk. It will be noted that the inner piece *E* projects into the pocket $\frac{1}{4}$ " , the space above it being filled by the partition. The joint between *E* and *B* would look best if glued, but if carefully fitted this need not be done, as there is ample strength without. The bottom board is then put in and nailed firmly with wire nails through *C*, *D* and *E*.

The partition board *F* is 7" long, $3\frac{3}{4}$ " wide and $\frac{1}{4}$ " thick, the inner end being cut to an angle of 20° , and also cut away on the under edge to fit over the board *A* where it projects beyond the pocket. It is fastened by nailing along the lower edge to *A*, at the end to *C* and a nail on the other end drawn into *A*. Two legs $4\frac{3}{4}$ " x $2\frac{1}{2}$ " x $\frac{3}{4}$ " are screwed to the cleat, at the *C*' end, to level the board.

A strip of rubber $\frac{3}{4}$ " wide and $\frac{1}{2}$ " thick is then glued along the inside of *C*' for a cushion for the ball; a piece of a carriage tire, packing or other form, if the kind used on billiard tables is not easily obtained. A set of ten pins about 4" high is the most suitable size. A large glass marble or small billiard ball is the most suitable for the ball. If stained in mahogany, varnished and brass trimmings put on the corners, it will have quite an attractive appearance. A small moulding with a flat top can also be added to the upper outside edge. The bottom and sides of *B* and *C* are covered with green baize or felt. The pocket is thickly padded with cloth before covering, a piece of pile carpeting being best for the purpose, and generally obtainable for the asking from the waste pieces of a carpet store. The location for the pins may also be indicated by red paper seals. A billiard cue completes the outfit. In use the board is placed upon a level surface, the ball is driven from the little alley at the side of the pocket against the pins, counting being the same as for regular bowling. It will be found a matter requiring considerable skill, to make good "strikes," and a decidedly interesting game to play.

BAGATELLE BOARD.

The general construction of this game is quite similar to that just described, excepting the shape

and omission of the pocket. A bottom board 45" long, 21" wide and $\frac{3}{4}$ " thick is required. This will have to be glued up from two pieces, and then carefully leveled with a plane. Three cleats 20" long 4" wide and $\frac{3}{4}$ " thick, are screwed to the bottom to prevent warping. The side pieces are

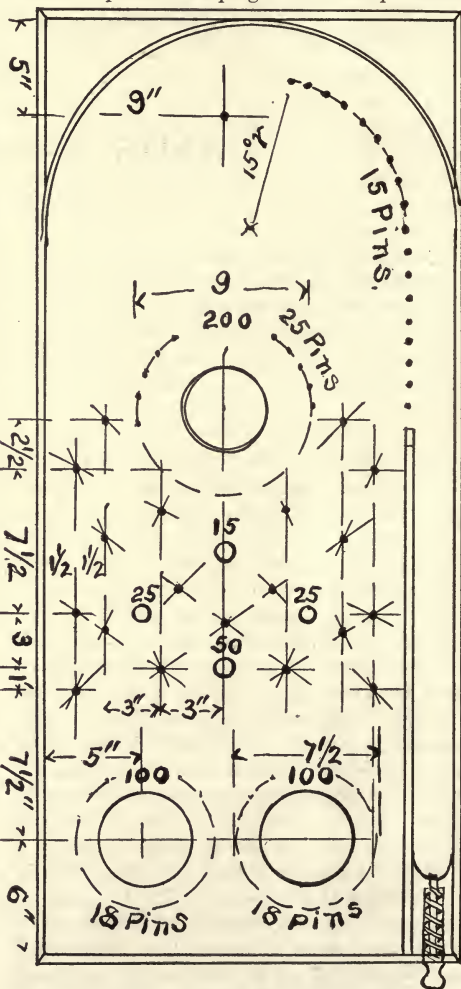

$4\frac{1}{2}$ " long, 3" wide and $\frac{3}{4}$ " thick. The end pieces are $22\frac{1}{2}$ " long, 3" wide and $\frac{3}{4}$ " thick, the joints being mitred. An alley 2" wide is made at the right side by means of a strip of wood 21" long, 2" wide and $\frac{3}{8}$ " thick, the upper end being

cut to an angle of 25°, and is fastened in place by means of long screws of small gauge, put through from the inner side and end piece.

The curved piece at the top is made from a clear strip of wood taken from a cheese box, planed smooth and of even thickness, and is about 27" long, and 2 ¼" wide. The ends are let into the side pieces so as to make a smooth curve with a radius of 10 ½". Holes 1" diameter are bored ⅝" deep, preferably with a Forstner bit, so as to leave no screw holes or spur marks. The location of the holes and also for the pins are plainly shown in the illustration. The pins are strong brass round head nails 2" long, which may have to be obtained on special order by your hardware dealer. They should be evenly spaced, their location being first drawn out on paper and then marked on the board by pricking through. In the centre of the 200 circle a 4" gong is mounted, and also in the 100 circles, 3" gongs. This may be done by twisting a piece of tin into a tube of the proper length to bring the edge of the gong ½" above the board and then putting a round-head screw through to hold it.

A block of wood 7" x 2 ¼" x 2" is fitted to the

lower end of the alley, a hole ½" diameter bored through it lengthwise, and the inner end cut to a half circle as shown to receive the marbles. A plunger may be made from a piece of ½" dowel, with any suitable handle such as a brass door pull fastened to the outer end, with which it is pulled out and also serving to hold it. A heavy rubber band is tacked to the side and end, and tied to pull knob, to give a strong recoil when the plunger is released by the fingers, after being pulled out, or the hole in the block may be made larger and a strong wire spring put over the plunger, one end being fastened to the inner end of the block, by putting it through a small hole bored for the purpose and plugged; the other end being carried around the screw of the knob.

Before putting in the pins or the gong, the wood should be stained, and varnished. Small moulding around the edges will also add to the appearance. Short legs to bring the upper end from 6" to 9" higher than the lower end should be fastened with hinges to the cleat on the upper end. The incline is a matter of choice as to whether it shall be greater or less than above. The marbles should be about 1" diameter.

THE DESIGN AND USE OF GAS ENGINES.

FRANK N. MARTIN.

I. Types of Engines.

The extensive increase within the last few years in the use of gas engines as generators of power for automobiles and launches, and to almost as great an extent for stationary purposes, has developed a general interest in their design and use, and it will be the purpose of this series of articles to so present the subject that the reader will, at their completion, have sufficient knowledge to be able to clearly understand the general features of the different types, and the proper workings of their path.

The designation of "Gas Engine" as here used includes all engines using gas or oil vapor for producing an explosion in the cylinder of the engine, but owing to the limitations of space, only the more commonly used types will be described.

It is well to mention, however, that engines using kerosene or petroleum vapor, as well as acetylene gas, are receiving much attention at the hands of inventors, and successful results have already been achieved. In the near future, therefore, we may expect important developments in these other types of engines.

Gas engines require a mixture of inflammable gas or vapor and air, the mixture of the two being effected before introduction to the cylinder and subsequent combustion. Air is an important necessity for two reasons; that of providing the necessary amount of oxygen to render combustion possible, and to secure the expansive effect due to the heat generated by the combustion or explosion. In fact, the greater the amount of air

used in effecting the mixture, the more economical the engine, from the greater expansive effect of the larger volume of heated air.

The working process of a gas engine is as follows:—The mixture of explosive gas and air is introduced into the cylinder, then compressed explosion follows, generating a high heat and consequent pressure forcing the piston outward. The products of combustion, gases of a different character, are then expelled from the cylinder, which is then recharged with a fresh mixture and the process repeated.

The working cycle of an engine is seen, therefore, to consist of four parts; charging, compression explosion and expansion, and exhaust. When these are effected by four movements of the piston, two outward and two inward, or two complete terms of the crank, it is termed a "Four Cycle" engine. When only two movements of the piston, one in each direction are necessary, it is a "Two Cycle" engine. With the four cycle engine, during the first outward stroke of the piston, the mixture is drawn into the cylinder at atmospheric pressure by the suction of the piston, the inlet valves closing at the end of the stroke. The first inward stroke compresses the gas to a high pressure and occupying but a small portion of the space at the inner end of the cylinder. Combustion follows generally just previous to completing this inward stroke. The pressure caused by the heated gases and air then causes the second outward or impulse stroke, the return stroke clearing the cylinder of the gases produced by the combustion, and completing the cycle.

With the two cycle engine, the compression of the gas and air mixture is effected in an external chamber, usually the crank case, which is made strong enough to withstand considerable pressure, and small enough so that the piston on its outward stroke will cause the compression of the mixture therein contained. When the piston, on its outward travel, has reached a certain point, an inlet valve admits the compressed mixture in the crank case to the cylinder, the entry being rapid owing to its compression. The inward stroke of the piston then begins, the inlet valve closes, the mixture is compressed, then exploded at or about the end of the inward stroke when the compression is greatest, the high heat causes the outward or impulse stroke. At a certain point in the out-

ward stroke an exhaust valve opens, the gases escape in part, so that the pressure is greatly reduced. This is quickly followed by the opening of the inlet valve, the incoming mixture of fresh gas assisting to force the exhaust gases through the exhaust opening, and the process is repeated as before. In this type of engine the several parts of a cycle more or less lap on to the one succeeding it, with the result that each part is not as fully completed as with the four cycle type, and the speed of the crank shaft cannot be as great, therefore, with the former as with the latter kind. The gain in power due to the increased number of impulse strokes is offset to quite an extent by the slower speed at which the two cycle engine must run.

The uses, therefore, for which the engine is intended, and its size and power enter considerably into the determination of the type to be selected. As a general proposition it may be stated, that for small engines of one cylinder up to 5 H. P. the two cycle type is most largely used, but for larger engines, and especially those of two, three or four cylinders, the four cycle is preferable. This has reference to marine and automobile engines. For stationary purposes, this statement must be modified by matters which will receive consideration in a future chapter.

CONTINUED IN THE JANUARY NUMBER.

The most expensive saws in the world are those in use in the factories of Pennsylvania, where various articles are manufactured from the slate. In one of these factories there are 300 horizontal saws, 12 ft. long, each of which is furnished with seventy-five cutting diamonds, each saw being worth \$5000. Roofing slate is split and turned by special machinery; but when the slate is cut up for use in other ways the procedure differs. The huge horizontal saw, with its scores of diamonds, is lowered upon one of the blocks of slate by a ratchet at the rate of $\frac{1}{4}$ in. per minute. The saw would cut through iron or steel at the same rate. A stream of water plays upon the slate to keep it cool and wash the dust from the cut. After the sawing, the block is planed by being moved backwards and forwards by machinery under a firmly fixed chisel. It is afterwards polished, much as blocks of marble are.

A MODEL ELECTRIC RAILWAY.

ROBERT GIBSON GRISWOLD.

IV. A Semaphore.

The electric semaphore is an electrically operated signal which denotes, in the case of a block system, a clear or otherwise block, or section of track. The fact is indicated by the position of the semaphore arm with regard to the pole. When it hangs down at an angle of about 30° the block beyond, and over which it has control, is supposed to be clear; if the arm stands at an angle of 90° as shown in the cut, the block is already occupied by another train or car as the case may be.

In order that the semaphore may properly perform its function it is necessary that an electrical connection be made such that the presence of a car upon that particular track controlled by the signal will cause the solenoid to draw the arm into a horizontal position. In the present case this is accomplished by insulating the two rails from each other in every section of track where this signal is used. A wire is then connected between each rail and one of the solenoid terminals, one of these wires having a small battery connected in series with it so that the current when passing through the rails, across from one to the other through the car axle, and through the solenoid will cause the signal to act. This semaphore cannot well be worked from the general current on account of the difficulty in winding the coil so that a small current will make it sufficiently powerful, and the interposition of the proper resistance to keep the power current from operating the signal at other than the proper time.

The movable arm is mounted on the side of a pole about twelve or fifteen inches high as shown. It is lightly pivoted on a small wire nail, the motion being limited by two similar nails being driven in above and below the arm. The arm is best cut from aluminum and one end provided with a circular opening into which a piece of red glass is cemented with pitch. The weight of this glass should not be so great as to overbalance the longer end, but the latter should be sufficiently

heavy to cause the arm to fall when the current is shut off, drawing the iron core out of the coil as it falls. The vane or longer portion should be painted red with a white strip across the outer end, or this stripe may be made by leaving the metal unpainted.

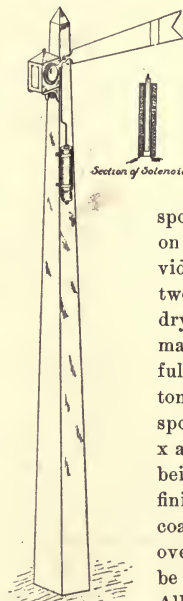

The solenoid is simply a coil of wire wrapped around a small tube of paper. This coil acts as a magnet when the current is passing around it, and will draw a piece of iron into the tube with considerable force. Make the spool either of wood turned out on a lathe, or a stiff paper provided with two flanges and given two coats of shellac. When quite dry place spool on a small wood mandrel and proceed to wind it full of No. 25 B. & S. single cotton covered magnet wire. The spool should be about 1 1/4" long x about 3/8" in diameter, the hole being 1/8" in diameter. Give the finished winding two or three coats of shellac and place in an oven to dry, after which it will be found very hard and firm. Allow the ends of the wire to extend from the coil at least 15".

The core for this solenoid is made of a ten-penny wire nail which is about 1/8" in diameter, and slightly shorter than the coil. One end is fastened to a wire which runs up as shown and hooks fast to the arm about 1/4" from the pivot. The iron core should move easily in the spool, and a small nail or pin driven into the pole just above the spool will serve to prevent its touching the tube while moving. The solenoid may also be located at the base of pole, enclosing it in a box frame with sloping roof to represent a signal box

A small tin lamp box is made and attached to the pole, inside of which is secured a small pea electric lamp, the wire from which pass down the side of the pole or through a hole drilled through the centre of the pole, the wires entering a hole drilled at right angles as shown for the solenoid wires. This makes a very neat job. The lamp box is provided on the side with a circular opening which is just the size of the glass in the semaphore arm. When the arm falls the red glass uncovers this opening and the white light shows instead. The light should be connected to separate battery, as in fact they all should, so that shutting down of the power current will not affect them.

This signal may also be used to indicate the condition of a switch on the main line; one position, generally the horizontal, indicating that a switch is open; the fallen position indicating that the track is clear and the switch closed.

Olona, which has been made an object of experiment by the station of the Agriculture Department at Hawaii, seems likely to become an important textile. It belongs to the nettle family, resembling ramie, but having no resin, it is easier manufactured than the plant. Ordinary sized ropes made of olona fibre are silken in their fineness and as strong as a ship's hawser. Ropes, nets and fish-lines are found to be impervious to the action of salt water. In Hilo, an aged native fisherman was found using an olona trawl which he had inherited from his grandfather. The line still seemed to be as strong as a steel rope. Olona is also remarkably light. Strands that weigh no more than twine have the strength of wire. Garments woven of this fibre, though delicate in texture, are said to be almost indestructible, and with ordinary use will outlast the lifetime of the wearer. It thrives best in Tropical forests 2,000 ft. above sea level.

Professor Max Wolf, the director of the Observatory at Heidelberg, has discovered, by means of photography, two new planets, having a radiance approximately equal to that of stars of the twelfth magnitude.

Renew your subscription promptly.

MACHINE DRAWING.

II.

The shapes of rivets and rivet heads were given in the previous plate. Three examples of riveted joints are here given. That shown in Fig. 7 is a single riveted lap joint. The general usage governing the spacing of the rivets for such a joint is:—The distance from the edge of the plate to the rivet hole, or to the next rivet hole, shall not be less than the diameter of the rivet, the shearing stress on the rivet and the tearing limit of the plate being assumed to be about equal. The thickness of the plates and the diameter of the rivets are determined by the pressure to which the joint is to be subjected. The objection to a lap is that the straining force of one plate is not in line with the joint, but tends to bend it with consequent weakening effect.

A single riveted butt joint is shown in Fig. 8, the edges of the plate being brought together, and a strap of suitable width covering it. Two straps, one on either side of the joint, are also used, thus over-coming the bending action previously mentioned, and to which a butt joint is subject to nearly the same amount as the lap joint, with a single strap butt joint it is customary to use a strap which is one-tenth to one-eighth thicker than the plates. When two straps are used the thickness of each is about five-eighths that of the plate.

The double riveted butt joint is shown in Fig. 9, the spacing between rivets being clearly shown. A simple riveted joint has about 60 per cent the strength of the plate, and a double riveted joint about 75 per cent. As constructional requirements frequent necessitate joints so shaped as not to permit of riveting in the ways just shown, the shapes shown in Figs. 10 to 13 are used. Fig. 10 is that known as angle iron, its thickness being generally a little greater than that of the plates used with it. A slight taper is also given it so that the root will be thicker than the edges. Fig. 11 shows a T iron, used for holding plates and also stiffening them against flexure. Fig. 12 gives a shape of channel iron, much used in locomotive construction. Fig. 13 is H iron, which is another commonly used shape.

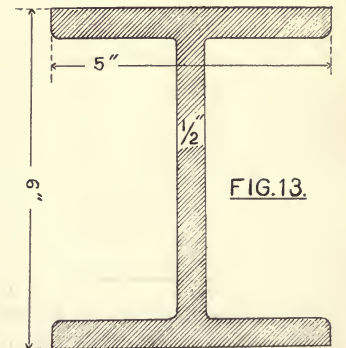
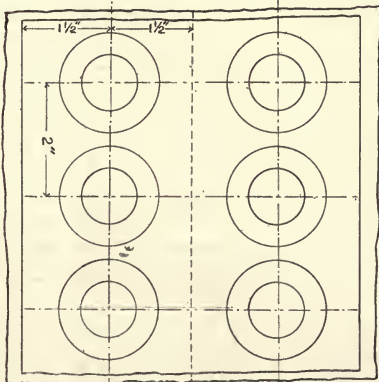
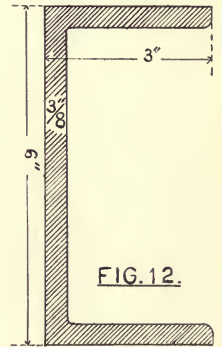
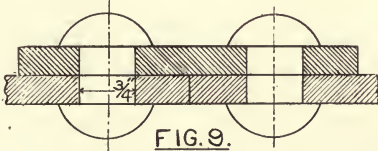
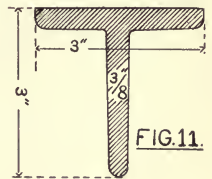
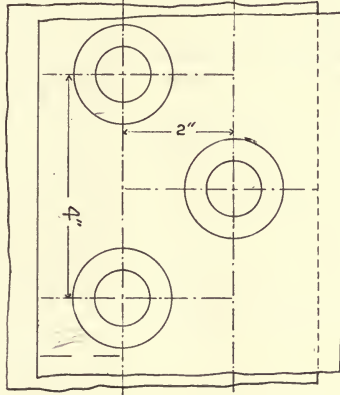
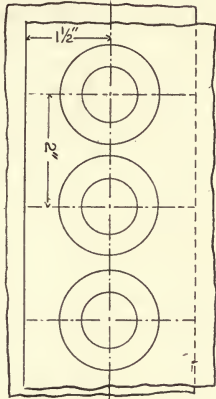
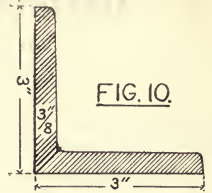
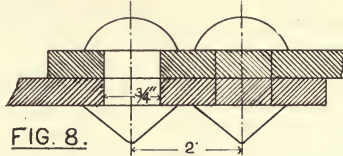
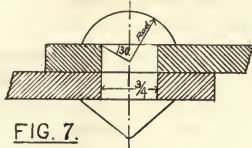

AMATEUR WORK

77 KILBY ST., BOSTON

DRAPER PUBLISHING CO., PUBLISHERS.

A Monthly Magazine of the Useful Arts and Sciences. Published on the first of each month for the benefit and instruction of the amateur worker.

Subscription Rates for the United States, Canada and Mexico \$1.00 per year. Single copies of any number in current volume, 10 cents.

TO ADVERTISERS.

New advertisements, or changes, intended for a particular issue, should reach the office on or before the 15th of the previous month.

Entered at the Post-office, Boston, as second-class mail matter
Jan. 14, 1902.

DECEMBER, 1903.

This is the last month of the special prize offers. Some of our readers will secure valuable tools, and the magazine a largely increased list of interested readers.

The near approach of Christmas leads to the suggestion that new subscribers are easily secured this month if a little thought is given to selecting those who would be likely to be interested in the magazine. But few subscriptions are necessary to secure some of the many excellent premiums offered.

The large holiday business at the bindery has delayed the delivery of the bound volumes much beyond the time when they were promised, but volume II is now ready, and the reprint of volume I is nearly complete, and will soon be ready for delivery. These are excellent for Christmas presents.

The special premium offer of a Weno $3\frac{1}{2} \times 3\frac{1}{2}$ camera for five new subscribers is an opportunity of which early advantage should be taken, the supply being quite limited, and the offer cannot again be made. See our advertisement for par-

ticulars, and learn that this is a chance to secure a fine camera with but little trouble.

Rock-salt mining is carried on extensively in five districts of New York State. The shafts are sunk in the usual manner, and the sides are prevented from caving in by heavy timbers, while to prevent water from entering the shaft a heavy layer of cement is put between the walls of the shaft and the timber. The shafts vary in size somewhat, the usual dimensions being 12' x 18', and 24' square in the clear. The main galleries are about 30' wide, their height depending on the thickness of the salt beds. Some salt must always be left as a roof and floor; hence, in a vein of salt 24' thick, an allowance of 6' for the roof and 4' for the floor would give a gallery or chamber 14' high. From the main chambers cross sections or galleries are run every 30'; thus the roof above is supported by pillars 30' square. The salt is blasted out with dynamite. The drills are run by compressed air about 6' into the solid salt, and they are set in such a manner that when the blast takes place, as much as possible of the salt remains in lumps. The salt is loaded into small cars, which are run on tracks laid on the floors of the chambers on to cages in the shaft, through which they are carried or hoisted to the top of the breakers, similar to those used in coal mining, and from 100' to 145' above the surface of the ground. To separate the lump salt from the finer material, the contents of the cars are dumped on a set of iron bars, which permit all the salt, except the lumps, to fall through into the crusher below; the lumps are loaded on to other cars and run down an incline to the ground, where they are stored, usually in the open air, for shipment. The finer material passes through the crushers on to sieves, and from the latter into the bins. Of the crushed and sifted salt, there are four kinds, according to size. The lump salt is mainly used for stock, the other grades for the same purposes for which sea or solar salt is required.

Sycamore, a most durable wood, is the substance of a statue known to be nearly six thousand years old, and now in the museum of Gizeh, at Cairo. The wood is stated to be quite sound and natural in appearance.

A JOLLY BALANCE.

ROBERT GIBSON GRISWOLD.

The jolly balance is especially convenient in the determination of the specific gravity of solid substances, insoluble in water, on account of the rapidity with which the work can be done. Owing to the fact that it is not necessary to obtain the actual weight in air, and that the readings are merely comparative, skill in rapid handling and accuracy in readings is soon acquired.

The specific gravity of such bodies as pieces of metal, alloys, ores and most minerals in general can be determined in a few minutes. The base *a*, is of triangular form and provided with three leveling screws, as shown, to level the instrument and bring the pans *c* with their suspension into a vertical line parallel to the pillar *d*. The triangular base *a*, is best made of $1\frac{1}{4}$ " oak, as this adds sufficient weight to make the instrument steady while in use. It is sometimes advisable to attach to the under side of the rear base arm a piece of sheet lead, say $\frac{1}{4}$ " thick so that overturning will not be likely. Over the centre of the base glue the circular block *e*, and through both the base and block a $\frac{3}{8}$ " square hole is cut, into which the pillar *d* is driven and glued.

The pillar *d* is best made of maple, 1" square. The lower end is tenoned to fit into the $\frac{3}{8}$ " square hole in the base. The shelf *f*, is circular and 4" in diameter, being glued to the bracket *g*, the latter in turn being secured by two thin screws to the pillar as shown. Upon this shelf is placed the beaker of water during the determination.

To the top of the pillar is fastened a brass guide *h*, being provided with a $\frac{1}{2}$ " hole through which a $\frac{1}{2}$ " brass tube passes. Just below on the same pillar is fastened another guide *i*, having the same size hole. These two guides carry the rod or tube *j*. The tube *j*, is the only moving part of the balance and carries the spring *k* suspended from an arm *l*, together with the pans *c-c*. It is made of $\frac{1}{2}$ " outside diameter brass tubing which is quite true to size and very straight. The upper end is fitted with a plug which is sweated in, the end being filed off perfectly square. This plug is

then drilled and tapped for a 10-32 brass round head screw. The arm *l* is filed out of $\frac{1}{16}$ " hard sheet brass and provided at the outer end with a boss and screw by means of which the spring *k*, is readily attached or detached.

To the lower end of the tube *j*, is attached a piece of thin sheet brass which just bears against the back of the pillar and keeps *j*, from turning. The pressure should be only sufficient to accomplish this object, and no move else the tube will work stiffly and accurate adjustment be rendered impossible. The construction of the lower end of this rod is shown in Fig. 3, also the lower guide and the stud to which the operating wire is attached. The spring is simply soldered to the end of the tube.

The tube *j*, is raised and lowered by means of a fine steel wire passing over a sheave on the top of the pillar and wound around a drum at the base, this drum being provided with a hand-wheel to enable it to be turned in either direction. The shaft passes through a hole in the pillar and from the hole is cut a saw slot running longitudinally for $\frac{3}{4}$ " on each side. A screw passes from the back into the front of the pillar by means of which the wood may be compressed upon the shaft and thus holding the drum from turning. The wire should be about No. 30 or 32 steel.

Make the pans *c-c*, from sheet aluminum. They may be cupped if desired by beating to shape with a ball-pene hammer on a block of hard wood afterwards trimming to exact shape. They are supported by three fine copper or brass wires as shown. Pass the wire through the hole in the upper pan, then wrap once around itself as shown and then pass down to the lower pan. The intersection of the three wires from the upper pan is joined by a drop of solder to a straight piece of brass wire, about No. 25. One inch and a half above the joining of the three wires and this straight brass wire solder a small brass washer $\frac{3}{8}$ " in diameter, and placed at right angles to the wire, to prevent undue oscillations.

To the pillar attach a block *o*, provided with two brass forks as shown in Fig. 4, which limit the travel of the pans. The spring *k*, is made of fine steel wire, No. 30 B. & S. wound on a slight-

to afford a means of attachment to the arm. The lower end should be made into a small hook to which the pans are attached. The reason for making the spring tapering is to avoid the undue

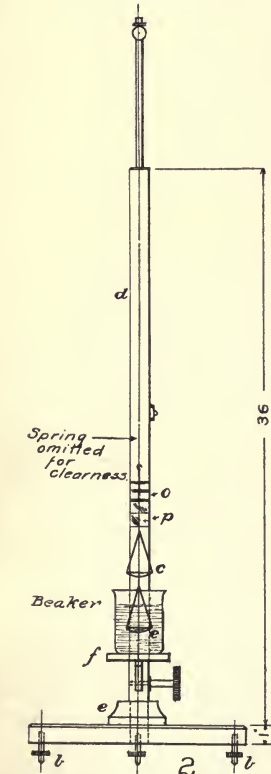
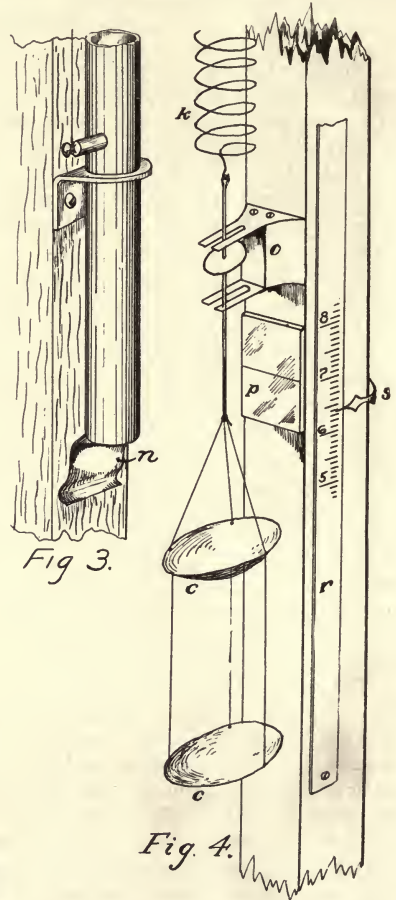
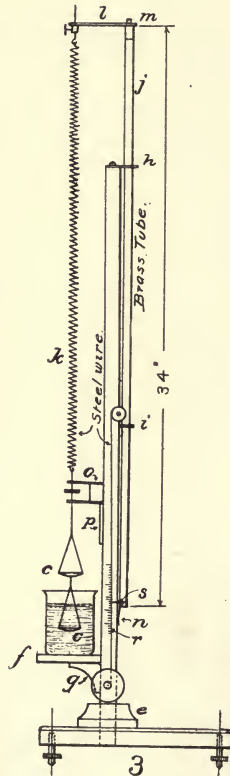
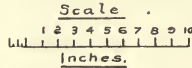
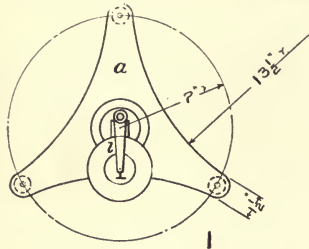

ly tapering wood mandrel, 12" long, $\frac{3}{4}$ " in diameter at one end and $\frac{1}{4}$ " diameter at the other. The coil should be about 5" long when closed. Solder the upper end, which is the end with the smaller diameter, to a short piece of copper wire

stretching of the upper coils due to the weight of the coil itself. With this method of construction the coils gradually increase in strength from the bottom upwards.

Just below the block *o*, secure to the pillar a piece of mirror *p*, as shown in Fig. 4. Across the face of the mirror scratch a fine line with a sharp end of a file, at right angles to the vertical axis of the instrument. Blacken the supporting wire

of the pans as indicated with india ink or lamp-black and oil, having the upper end of this blackened portion level with the line on the mirror when the washer is midway between the forks. Make a millimeter scale *r* of Bristol board about half a meter in length and attach to the side of the pillar as shown, numbering from the bottom upwards by tens. To the lower end of the rod *j*, fasten a brass pointer *s*, the sharpened end of which will just clear the surface of the scale. Make the scale divisions distinct and the ends of the pointer very sharp.

To illustrate the use of the balance, a determination of the specific gravity of brass will be used. The beater is nearly filled with freshly boiled distilled water. The rod *j*, is then adjusted by means of the hand-wheel until the edge of the blackened portion of the wire coincides exactly with its image in the mirror when looked at from the front. The reading on the scale is then taken and set down.

Now place the piece of brass in the upper pan and again adjust the rod *j*, until the image and blackened portion coincide and set down the reading, subtracting the first reading from it, the result corresponding to its weight in air. Then place the piece in the lower pan, being sure that it is completely covered with water, and adjust as before. This reading minus the first corresponds

to its weight in water. Then calculate the specific gravity as follows:

Reading with body in air	127.3 mm.
Reading with pans empty	7.4 mm.
Spring extension due to weight in air	119.9 mm.
Reading with body in water	113.1 mm.
Reading with pans empty	7.4 mm.
Spring extension due to weight in water	105.7 mm.
Weight in air	119.9
Wt. in air - Wt. in water	$\frac{119.9 - 105.7}{14.2} = 8.4$

From the above will be seen that this method agrees precisely with the method in which a balance and weights are used. The above form of calculation is given in order that a clear understanding of the principle involved may be had by those unfamiliar with this class of work. It will often be noticed that text books give the following formula which is identically the same thing.

$$\frac{B - A}{B - C} = \text{Specific gravity}$$

- A = Instrument reading, nothing in either pan
- B = Reading with substance in upper pan
- C = Reading with substance in lower pan

Inserting the assumed values given above we have

A = 7.4 mm.
 B = 127.3 mm.
 C = 113.1 mm.

$$\frac{127.3 - 7.4}{127.3 - 113.1} = \frac{119.9}{14.2} = 8.4 = \text{specific gravity}$$

A HAND CYLINDER PRINTING PRESS,

Suitable for an Amateur's Newspaper, Posters and Proofs.

Many amateur printers find the cost of a press large enough to print a small newspaper, much too great to permit of their obtaining them, and so are obliged to do without the instructive pleasure and profit incident to amateur journalism. As the work of printing the paper is quite as enjoyable as that of editing it, the press here described will afford those of fair mechanical skill a way*to have a press upon which good work may be done at fair speed. It is much like the old Adams hand press, many of which are still to be found in small towns where a small weekly paper serves up the local news to a very limited number of subscribers. The size here described will print a form 14" x 20" or the size of two pages of this magazine. A very neat amateur paper of four pages could be printed by running two pages, and then

turning and running the other two pages.

The frame is made of 2" x 3" spruce joist, which planed all over will measure 1 3/4" x 2 3/4". The four pieces *A*, are 61" long, mortises 7-8" wide, being cut 1" from each end for receiving the tenons on pieces *B*. All mortises and tenons should be very carefully cut on each end. In addition, cut mortises 1" wide, 5" and 18" from the lower ends for cross pieces *C*. Four pieces *C* are 16" long, tenons being cut on each end to fit mortises in *B*.

The four pieces *D*, are 47" long, and bolted 3 3/4" apart to the pieces *A*, after attaching the cross piece *E*, and fitting the pieces *H*, which are mortised, the lower edge being 25" from the floor. The two pieces *H*, are 10" long, with tenons on each end. The piece *E*, is 22" long, 3 3/4" wide, and 2 3/4" thick, and fast-

ened to the top ends of *D* with 1-4'' lag screws with washers under the heads. Bore holes for these screws before driving and place them so they will not interfere with the bolt *M*. The centre line between pieces *D*, is 25 1-2'' from the left ends of the frame pieces *A*, as shown in the illustration.

The two pieces *J*, are 8'' long, and fastened with 3-8'' lag screws to the under side of the pieces *A'*, the fit of the joint being square and close. A 1-4'' hole is bored 31'' from the left end, the centre of the hole being in the joint between the two pieces *J* and *A*, and the hole being bored exactly square and true. Pieces of brass tubing 2'' long, 1'' internal diameter and 1-8'' thick are then fitted to these holes, forming

countersunk for the heads of the screws. The top surface of the brass plate should be absolutely level, smooth, and firm, so that the type form will be evenly and firmly supported. Along each side are screwed maple strips *F'*, 24'' x 5 1-2'' x 1 1-2'', the lower edges being dropped 1 1-2'' below the under side of *F*, and about 1 1-16'' above the top of *F*, forming bearers for the ends of the cylinder *O* to rest upon. The upper edge should be absolutely even and exactly the same height at all points. The ends are slightly beveled, so the cylinder will be taken up easily. These pieces form the runners for carrying the bed *F* to and fro. Before finally fastening in position, carefully measure the distance between the inner

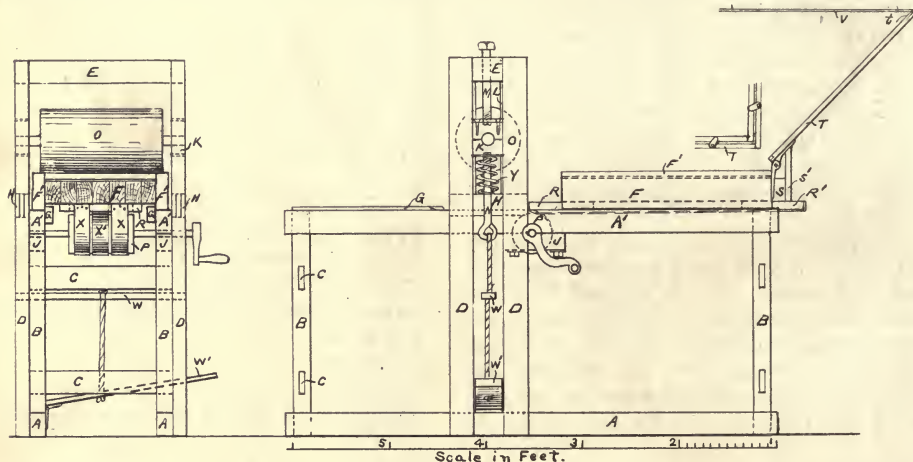

a bearing for the shaft of the cylinder *P*. This cylinder is of wood 5'' in diameter, and 8'' long, and preferably should be glued up of four pieces and then turned down. The shaft for same is 1 1-4'' square drawn steel, 22'' long, turned down in a lathe to 1'' for the bearings, the length turned on one end being 3'' and one on the other 6''. Or a solid cylinder of wood can be bored at each end with a 1'' bit and pieces of 1'' shafting fitted therein, but great care must be used to locate the holes exactly in the centre of the ends. The outer front end of the shaft is filed square to fit a handle; one used for grindstones will answer, and these may be purchased at most hardware stores.

The bed *F* is glued up from strips of selected maple, which has been well seasoned. The dimensions are 14'' x 24'' x 2 1-2''. Unless the builder has suitable clamps this can best be gotten out at some wood-working shop, as it must be well done and the top absolutely level. When complete a sheet of brass 1-8'' thick, 24'' long, and 14'' wide is fastened with 1 1-2'' brass screws to this wooden support. Holes spaced 3'' apart are drilled all around the edge and

edges of the upper pieces *A*, and space the pieces *F'* a trifle further apart so they will not bind on the guides *G*. The lower inside edges of *F'* may be planed with a rabbet plane to secure the proper fit. On each corner of the bed *F*, are attached corner pieces made of brass bent to an angle and well fitted, and securely attached with several screws. These keep the chase in position when doing work. They project above the top of the bed a trifle less than the thickness of the chase and should not be fitted until the chase is secured so that the latter may be used in making the fit.

The movement of the bed is secured by means of belts fastened at one end of the cylinder *P*, and at the other ends to the frames *R*, fastened to the under sides of the ends of the bed. Three pieces 8'' long and 1 1-2'' square are needed for each frame; two projecting pieces and a cross piece. The joints are halved and firmly fastened with screws and the inner ends screwed to the under side of the bed. Three pieces of 1 1-2'' belting 38'' long, are required; the centre one being fastened to the frame at right or outer end of the bed, and the two outer strips to the

frame as the left or inner end of bed. The ends of the belting on the cylinder are fastened first, the bed moved the full distance to one end and the outer end of belt on that end fastened; then moved to the outer end and the end of the other belts fastened.

By turning the handle to cylinder *P*, the bed can be moved as desired. The guides *G*, are 61" long, 1" thick, and 2" high, and are firmly attached to the inner edges of the pieces *A'* so that they are 1-2" higher than *A'*. Graphite or axle grease is used to lubricate the ways. To the outer end of the bed two blocks *S*, 4" x 3" x 2" are attached, one on either side, to which are attached pieces *S'* 7" x 2" x 1", the upper ends being beveled. The tympan *T* rests upon these pieces when laid back for the insertion or removal of the paper.

The tympan is a double frame made of oak strips 3-4" x 1-2". These frames are made exactly alike, one fitting inside the other with about 1-16" space between. The end at *t*, is not made of wood, but of a strip of steel, 14" long, 1-2" wide and 1-8" thick. The outer frame is 25" long; and 15" wide, the inner one 23 3-4" long, and 13 3-4" wide.

The impression cylinder *O* is 8" diameter and 12" long. It should be built up from four pieces of clear grained, well seasoned maple, and mounted on a shaft made of 1 1-2" square steel. In addition to gluing, it is advisable to bore holes at each end through each two adjoining pieces and put through dowels which should also be well glued. When the glue is thoroughly dry, mount in a lathe and turn off the shaft for bearings to 1 1-4" diameter, and then turn down the cylinder, using care to have it of uniform diameter. As this part of the press may be beyond the capacity of some readers, it can be ordered at some pattern makers or wood working shop.

Another way to make it, and also the cylinder *P*, is to buy steel or brass tubing, close up the ends with wood or brass plate, carefully locate the centres and drill holes for a piece of 1 1-4" round shafting. It can then be mounted in a lathe and a light truing cut taken off, and then polished. If tubing is easily obtainable, this will cost less, and also be easier than to use wood. The shaft is 21 1-2" long, and 1 1-4" diameter. The journals *K*, are each made of two pieces of maple 3 1-2" x 2" x 2". The two pieces are put together in a vise and a 1-2" hole bored for the shaft, the centre being on the joint. Pieces of brass tubing are used for bushing, to prevent the shaft from wearing down the wood. Slots 1-2" wide and deep are cut on the ends vertically fitting the ways *L* made of 1-2" square maple strips 14" long. The bolt *M* and eye-bolt *N* are each 8" long, and 3-4" or 7-8" diameter. These may have to be made up to order by a blacksmith, in which case use steel shafting; so as to secure a smooth finished surface. The ends are threaded to fit plates screwed to the journals *K*. The hole in the piece *E* for the bolt *M* should be an easy fit, but not loose, as should also be the hole in the piece *H* for

the eye-bolt *N*. By turning the bolts *M* the impression of the cylinder is regulated. The plates at the top and bottom of the journal have projecting lugs, two inside and one outside, to receive the ends of 3-8" bolts 5" long, which hold the journal together but are not shown in the illustration.

Steel expansion springs 5" long, and strong enough to hold the cylinder up, are put between the journal and the piece *H*. Pieces of strong rope or twisted iron close-line, are attached to the eyes in the bolts *N* and to the ends of a piece of oak *W*, 21" long, 2" wide and 1" thick which is about 18" from the floor. From the centre of *W*, drop another piece of rope or wire to the treadle *W'* which is 22" long, 3 1-4" wide and 7-8" thick. The inner end of the treadle is hinged, with a strong T hinge to the piece *A*. The travel of the outer end need not be over 3". If the weight is too great for the springs under the journals *K*, a spring may be attached to the front end of *W'*. By pressing with the foot upon the end of *W'* the cylinder *O* is brought down on to the bed *T*, the latter then laying upon type with the paper between.

To prepare the press for work, the two frames of the tympan are each covered with a smooth covering of muslin or sheeting, the form placed upon the press, gauge pins located, and an impression taken on a sheet of the paper to be used for the run. If this press proof be examined, the impression may not be found uniform, in which case adjust the bolts *M*, and then correct local heavy or light places by pasting up and cutting out layers of paper which place between the cloth covering the two frames of the tympan. This is called the "make ready." A long two-handled ink roller and a piece of thick glass or marble are needed for inking, and a table for the blank and printed sheets. To take an impression lay a blank sheet upon the tympany ink the type, bring down the flies *V*, place the tympan upon the type, turn the crank carrying the bed under the cylinder, press the lever firmly but not too hard with the foot, turn the crank in the reverse direction bringing out the bed under pressure from the cylinder, lift the tympan, throw up the fly and remove the printed sheet. After a little practice, excellent work can be done on a press such as is here described. Any points not clearly understood by readers will be further explained in the correspondence column.

Hardness in lead pencils is obtained by compressing the graphite mixture into the form ready to be glued into the wood casings. A highly compressed mixture produces a pencil of greater wearing qualities, an important feature in a high grade pencil. Hydraulic presses are used for the purpose, and the mixture of clay and graphite, which is still in a plastic condition and has been formed into loaves, is placed into these presses, which are provided with a die depending on the sectional area of the lead desired; through this die the material is forced.

A POWER DORY.

CARL H. CLARK.

V. The Engine and Fittings.

The engine is now to be obtained and installed. The question of the best make will be largely a matter of personal preference and also of price. Almost all of the engines on the market are capable of satisfactory running if properly adjusted and taken care of. A large part of the trouble experienced by amateurs in running gasoline engines is caused by lack of proper adjustment. Good care should be taken not to change the adjustment of the engine as obtained from the makers until after it has had a thorough trial in the boat and the owner is familiar with its action under all circumstances.

When ordering the engine, the distance from the after side of the deadwood to the flat part of the bed should be given to the engine dealer, to be sure of getting the shaft long enough. In the matter of spark coil and batteries, it is to be urged that only the best be purchased, as use on salt water is very severe, and cheap materials very soon go to pieces, and cheap batteries very soon run out. It is advised that a magneto be used for ignition, using the batteries for starting only.

The first step will of course be to bolt the engine in place. It should be placed upon the bed, with the shaft in place in the hole in the deadwood. This hole is of course larger than the shaft, and the engine is now to be adjusted, either by cutting the bed slightly, or in any other way, until the shaft is directly in the centre of the hole. It may perhaps be necessary to trim the inside end of the hole with a gouge to get the proper clearance. At the same time the brace between the engine beds may be fitted to the round of the under side of the base, and then fastened in place by lag screws.

To get clearance for the fly-wheel, the beds will need to be notched out, this should be done until the fly-wheel has about 1-4" clearance. A clearance must also be allowed for the crank in starting. When everything has been brought to a good bearing, holes may be bored for the lag screws which hold down the engine. These screws will probably be 4 or 5 inches long, and the hole is bored to fit the size at the bottom of the thread. It will be rather a nice piece of work to fasten the engine into place without cramping the shaft and causing it to bind in the hole.

The stern bearing may now be slipped on over the shaft, and brought up against the deadwood, to which it is to be carefully fitted and bolted, with a layer of lead between. This piece, also, must be carefully fitted, or it will otherwise bind the shaft and cause

friction and wear. When all is secure, the engine should turn over freely by hand; this point is very important and must be carefully observed.

In describing the installation of the engine it will be hardly possible to give an exact description of all the work, as no two engines are piped up in exactly the same manner. When ordering the engine, detailed directions for fitting up should be asked for. In many localities the engine maker can refer the buyer to one or more of his engines already in use. Seeing an engine already in place will be of great help to the amateur builder, and together with the somewhat general directions here contained will enable him to fit up his engine with little trouble.

It will be best to have the several lengths of pipe cut and threaded by a pipe fitter from the measurements, as this work requires special pipe tools too expensive for the amateur to buy. The heavy piping for the exhaust should be fitted first, together with the muffler. Some makers furnish two small mufflers instead of one large one. The mufflers are placed under the deck aft, and the exhaust is carried out through the stern-board. The exhaust pipe runs directly from the engine to the muffler, which is so placed that there will be space between it and the sternboard to easily accommodate an elbow horizontally, from the muffler the pipe extends horizontally a few inches, then with another elbow it extends up the sternboard and out through it, with another elbow and short pipe just above the rudder stock. In case two smaller mufflers are used, or for any reason, the arrangement outlined cannot be used, it should be kept in mind that the arrangement should be as simple and direct as possible.

It will be noticed that there is a union between the muffler and the engine; this is necessary to allow it to be fitted into place. In fitting up this piping, the part beyond the union is made up first to fit into place; the short pipe which extends through the stern-board is a threaded close nipple, and is to have a locknut screwed on outside when it is in place; the straight pipe in the forward end of the muffler is fitted with one part of the union. This portion is then held in place while measurements are taken for the pipe between the engine and the union; the latter piece is screwed into the exhaust hole in the engine and the connection made with the union. The necessity for the union will now be seen. A locknut is screwed over the short nipple on the outside of the sternboard to secure water tightness and hold the pipe in place. A cleat is fastened under the after end of the muffler

to take the weight and hold it in place. Whenever the pipe comes in contact with any of the woodwork a piece of asbestos should be tacked between to prevent the woodwork being charred by the heat.

most convenient. When the engine is received it will probably have a stem in the suction pipe ready to connect. The connection with the bottom or side must, of course, be water tight and is connected to the part already in place with a piece of flexible tube, so that the vibration of the engine will not disturb the connection with the plank. If it passes out through a

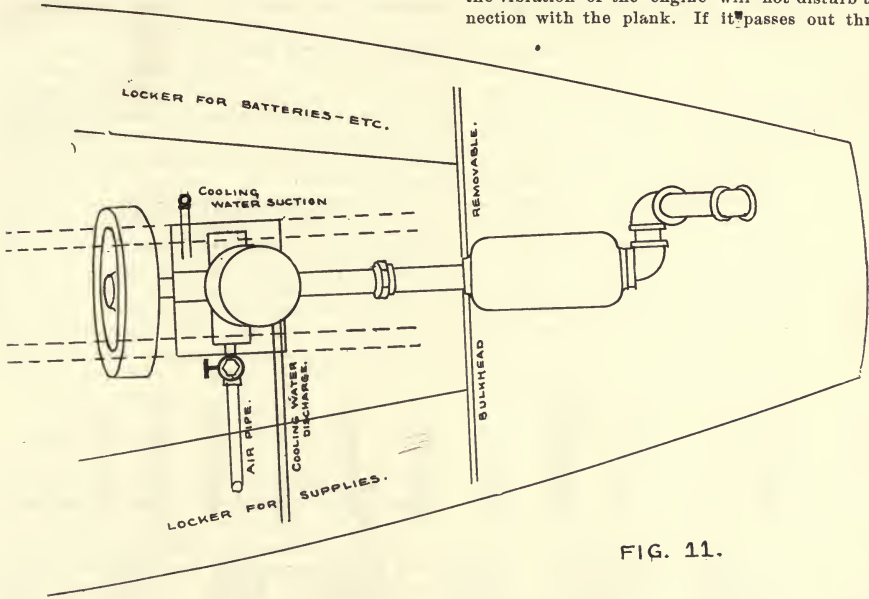
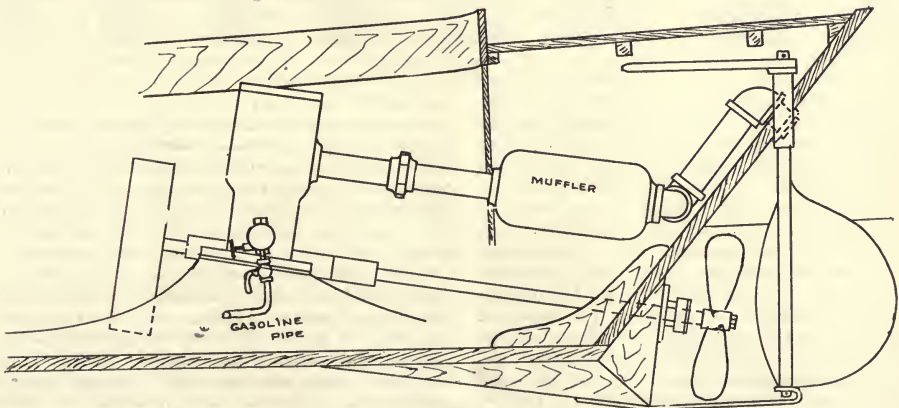

FIG. 11.



The cooling water should be piped up next. As will be seen, this water is circulated by a small pump, which draws water from the outside, and discharges it around the cylinder and overboard. The suction pipe leads either through the side or bottom, as is

plank, a piece of oak should be fastened on the inside to reinforce the plank.

A piece of fine wire gauge is to be fastened over the end of the pipe to prevent dirt from filling it. It is also advisable, but not absolutely necessary, to have a

valve on this water inlet next to the plank; this valve, when closed, prevents all chance of the boat being flooded by accident when not in use. The outlet from the engine leads outboard above the water line. The vaporizer is located near the base of the engine, and is connected to the tank by a small lead or brass pipe. Lead is preferable, as is easily bent to fit into place. There should be a stop-cock at the tank and at the vaporizer, and the pipe is connected to these by a wiped joint and union. There must be as few joints as possible in the gasoline pipe, as leakage at this point is very dangerous. The pipe should be placed under the seat on one side, running through holes bored in the moulds at about the height of the vaporizer, to avoid all low places, which pocket gasoline.

The vaporizer has also an air inlet which admits air, this may sometimes take air from around the muffler, but ordinarily has merely an open pipe. This pipe is to be led into a sheltered place to protect it from spray, and it must also be so placed that waste or cloths will not be drawn into it by the suction. It might well be led into one of the side lockers and a portion of it partitioned off.

All joints in water pipes should be screwed together with a coating of red lead between; joints in the exhaust pipe should be tight, but need nothing in them, in the gasoline pipe all joints should be wiped with solder, except those made by the unions themselves where a leather washer is used.

In fitting up the electric ignition, it should be borne in mind that a large proportion of the trouble with gasoline engines is caused by some defect in the electric system. The electric supplies are usually included in the outfit, but if they are not, the ones purchased should be the best in the market, as use about the water is very severe, and cheap articles soon go to pieces. If it is intended to run continuously on batteries, a double set, of 6 or 8 each should be used. They should be placed in a double row in a box which has previously been thickly coated inside with asphaltum paint, to prevent the collection of moisture. As shown in Fig. 12 the zinc of one battery is connected to the carbon of the next, the two wires connected to the two end zincs coming out through holes in one end and those on the two carbons at the other end. The cover should be fastened on. The whole is now placed in one of the side lockers, where it will be dry. The spark coil is thickly covered with wax, or other waterproof material, as water very soon spoils it. This coil is placed in the locker along side of the battery box.

A double point switch is placed on the outside of the locker in a convenient position. There are two connections on the engine, one to the body of the engine, termed the ground connection, and one to the firing pin. The connections are as follows:—The two wires at one end of the battery box are brought together, and joined to a single wire, which is in turn carried to one of the connections on the engine. The two wires at the other end are connected, one to each

outside point of the three point switch, and a single wire leads from the middle point to one terminal of the coil. A wire from the other terminal of the coil to the remaining connection on the engine completes the circuit.

It will be seen that when the switch is in connection with either point there is a continuous circuit formed through either set of batteries as desired, or it may be thrown off entirely when the engine is at rest. The joints in the wires should be carefully made, and might well be soldered. The circuit can be tested by closing the switch, loosening the wire from the firing pin and scratching it upon some of the bright parts, of the engine, a brilliant spark showing if all connections are complete.

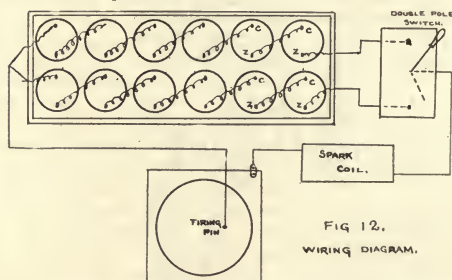

It is highly desirable that a magneto be used for continuous running, as batteries are inclined to become weak when used continuously. The magneto may be driven either by a friction pulley resting against the fly wheel, or by a belt on the flywheel, in which case it may, if desired, be placed in one of the side lockers, and the belt run through holes in the staving. The wires from the magneto are connected so as to simply replace one of the sets of batteries already described, a single set only being used. By changing the double point switch the batteries may be used in starting and the magneto switched in after the engine is in motion.

When the engine is all piped up the remaining bulkhead at the after end of the standing room can be fitted; it should be so arranged as to be easily removable, to get at the piping and tiller ropes. The floor may now be laid and fastened in place. It may be well to leave one board loose down the middle as there is a space 3" deep which may be used for small storage.

Before putting the boat into the water, the stern gland should be packed with suitable packing to prevent leakage around the shaft. Directions for starting the motor will usually come with each engine. If the amateur is not used to running this type of engine he should obtain assistance from someone familiar with gasoline engines and their operation. It is also advised that anyone unfamiliar with these engines get and study a copy of any of the recent works on gasoline engines and become familiar with the principles upon which they work.

PRINTING FOR BEGINNERS.

FREDERICK A. DRAPER.

II. The Method of Manufacturing Type and the Sizes.

Before considering the selection and handling of type, a brief description of the method of its manufacture will be given. First in the process is the making of the punch, a steel rod upon the end of which is cut the letter, figure, etc., a punch being required for each character in the font. A matrix is then made by driving the punch a short distance into a piece of bar copper, thus forming an indentation of a reverse shape to that of the punch. The matrixes are then used as ties in machines for the casting of type, the matrixes being changed as often as a sufficient number of type have been cast from them. One important peculiarity of type is what is termed the "nick," this being the slot or slots cut on the edge at the lower part of the

Until recently the sizes of the body or shank of the type were designated by a system which was not uniform with the different foundries, making it a difficult matter to use in the same line type from different foundries. Much time was required for "justifying" or making even the space occupied by the different makes of type. The introduction of what is known as the "point" system has removed this vexatious trouble, all type now manufactured in this country being upon this system. In this system the size formerly known as Pica is divided into 12 parts or points, other sizes being fractional or multiple parts or points of the twelfth part or point thus obtained.

The several sizes of the type body are clearly shown

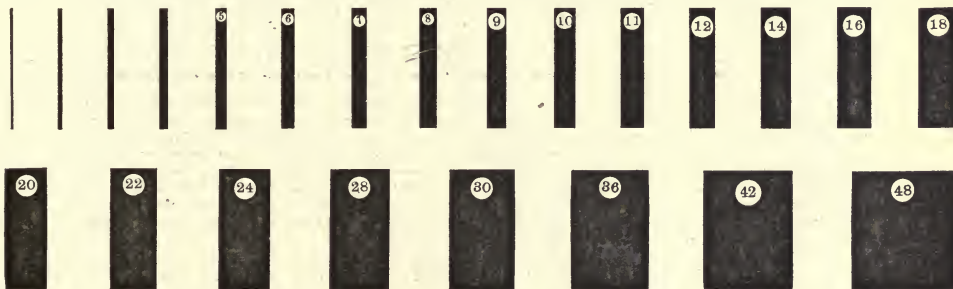

SIZES OF TYPE, POINT SYSTEM.

character. The number and shape of the "nicks" vary with different foundries, and the number and position are changed for different but similar faces of type made by the same foundry, thus forming a very convenient means for distinguishing the font to which a character belongs when distributing type with similar faces.

This important characteristic should be kept in mind when purchasing type, as having a series of fonts of a certain face cast by one foundry, a similar face with a different nick could be purchased of another foundry. This is easily done, as the larger type foundries all cast the more commonly used faces, though sometimes cataloging them under different names. It is more especially helpful to have different nicks upon the small sizes of body type, (the faces used for solid reading matter,) as most job faces are easily distinguished by the shapes peculiar to each face. The nicks also show to the compositor which side should be set uppermost in the composing stick.

in the illustration, the point number being used in cataloging and ordering rather than the former names, which are also here given.

3 Point Body	Excelsior
3 1-2 " "	Brilliant
4 " "	Semi-Brevier
4 1-2 " "	Diamond
5 " "	Pearl
5 1-2 " "	Agate
6 " "	Nonpariel
7 " "	Minion
8 " "	Brevier
9 " "	Bourgols
10 " "	Long Primer
11 " "	Small Pica
12 " "	Pica
14 " "	2-line Minion
16 " "	2-line Brevier
18 " "	Great Primer
20 " "	2-line Long Primer

24	" "	2	"	Pica
30	" "	5	"	Nonpariel
36	" "	3	"	Pica
42	" "	7	"	Nonpariel
48	" "	4	"	Pica
54	" "	5	"	Small Pica
60	" "	5	"	Pica
72	" "	6	"	Pica

The point system makes it a very easy matter to justify the lines made up of different sizes; two lines of 8-point equalling one line of 16-point; three lines of 8-point equalling one line of 24-point, etc. For that reason, as well as other advantages, it has rapidly replaced type cast on the old body and but little of the latter is now to be found even among dealers in second-hand material. The type here used is 8-point, other body type used in this magazine being 10-point and 6-point. This designation of sizes ap-

letters are such that a portion overhangs the body, this projection being called a "kern." These are most frequently found in italic and script type; also in some faces of job type, and are to be avoided where possible, as the kerns are easily knocked off in handling, type so injured presenting a poor appearance' as well as requiring more frequent renewal.

Type is sold in case lots of 25 pounds or more, or in fonts for job use, the sizes of fonts varying with the size of the type, and differing with the foundries, each one putting up fonts of sizes which probably seem best adapted to the several faces. The fonts for the smaller sizes of type contains a larger number of each character than do those for the larger sizes. The font "scheme" as the numerical arrangement of the font is termed, is so divided among the characters that the proportions of each will best meet the requirements of average work. It will be found, how-



CHARACTERS OF 30 A-60 a JOB FONT (HANSEN OLD STYLE, 6 POINT.)

plies only to the body, the face or part making the impression, covering the whole or only a part of the body. When only a part of the body is taken up by the face, the unused part is known as the "shoulder" which is variously cast either entirely above or below the face, or with a shoulder both above and below the face. Much of the type now cast is of "Uniform Line", that is, the shoulder is uniform with each of the several sizes, making it possible to set different faces in the same line, and have the whole line even in its impression. In purchasing new type this important advantage should be kept in mind, and preference given to type so cast. "Lining" type carries the same principle a step further, so that different sizes of type may be set in the same line and present a even line on the lower side. This permits of initial letters, or words which it is desired shall be prominent, being set in larger type than that surrounding it.

The face for one size of type is sometimes cast on the body of the next larger or smaller size, but this is done only to fill the requirements of some particular class of work. With some faces the shapes of some

ever, that a few letters are exhausted much in advance of the rest, necessitating the purchase of "sorts," letters are termed which are needed to again fit the case for continued composition. As foundries have a minimum price for a "sorts" order, always make the order large enough to get at pound prices the quantity of type covered by the minimum price. This can easily be done by adding to the order a few letters which are nearly exhausted. The assortment comprised in a 30 A-60 a is here shown. Job fonts are usually packed with the capital letters, punctuation marks and figures in one package, and the small letters or "lower case" in another. Some foundries are now dividing the punctuation marks between the two packages, which is very desirable, as frequently a certain class of work calls for several fonts of lower case but only one font of the capitals.

CONTINUED IN THE JANUARY NUMBER.

The Premiums given for new subscribers make good Christmas presents.

HAND SAWS, THEIR CONSTRUCTION AND USE.

EXTRACTS FROM "HANDBOOK FOR LUMBERMEN," HENRY DISSTON & SONS.

The teeth of a hand-saw should be filed so true that, on holding it up to the eye and looking along its edge, it will show a central groove down which a fine needle will slide freely the entire length; this groove must be angular in shape and equal on each side, or the saw is not filed properly and will not run true.

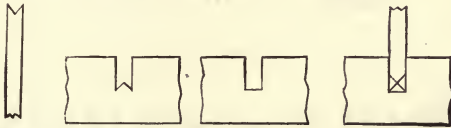

FIG. 4. FIG. 5. FIG. 6. FIG. 7.

Fig. 4 shows how the groove should appear on looking down the edge of the saw; the action should be such that the bottom of kerf will present the appearance as shown in Fig. 5, and not like Fig. 6; the cutting action is as shown in Fig. 7; the cutting being done with the outside of tooth, the fibre of the wood is severed in the two places and the wood is crumbled out from point to point by the thrust of saw.

The proper amount of bevel to give the teeth is very important, as is demonstrated by the above figures, for if too much bevel is given, the points will score so deeply that the fibres severed from the main body will not crumble out as severed, but be removed by continued rasping, particularly in hard woods, as they require less bevel, as well as pitch, than soft wood.



FIG. 8.

Fig. 8 shows a six-point cross-cut saw filed with a medium amount of bevel on front or face of tooth, and none on the back. This tooth is used in buck-saws, on hard wood, and for general sawing of woods of varying

degrees of tenacity. This style of dressing is the best, but a number of saws each having teeth suited to its particular work, will be found more advantageous than trying to make one saw serve for all kinds of hand-saw work.

We will now consider the cross-cut saw tooth, in regard to rake or pitch; this being one of the most important features, too much care cannot be taken to have the correct amount of pitch for the duty required. To illustrate this, Fig. 9 represents a board, across which we wish to make a deep mark or score with the point of a knife; suppose we hold the knife nearly perpendicular as at *B*, it is evident it will push harder and will not cut as smoothly as if it was inclined forward

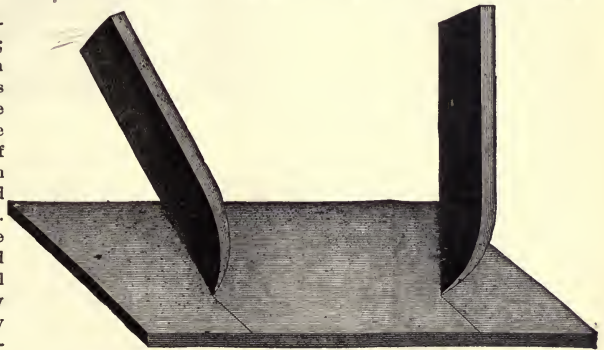

FIG. 9.

as at *A*; it follows then that the cutting edge of a cross-cut saw should incline forward as at *C*, rather than stand perpendicular as at *D*.

Too much hook or pitch, and too heavy a set are very common faults, not only detrimental to good work but ruinous to the saw; the first by having a large amount of pitch, the saw takes hold so keenly that frequently it "hangs up" suddenly in the thrust—the result, a kinked or broken blade; the second, by having too much set, the strain caused by the additional and unnecessary amount of set is out of proportion to the strength of the blade, and is broken in the same manner. The most general amount of pitch used is 60°, though this may be varied a little more or less to advantage, as occasion may demand.

The next point to be considered is the bevel, or fleam, of the point. In Figs. 10, 11 and 12, the filer, as

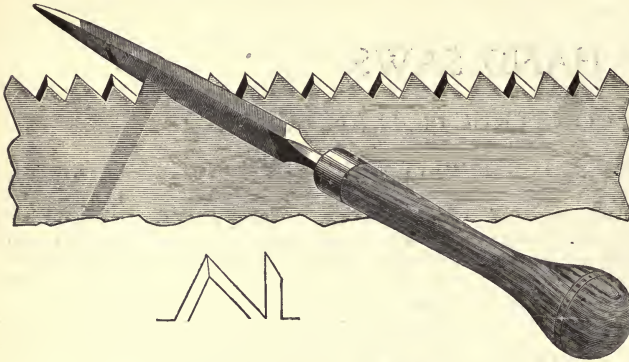

FIG. 10.

in all cases, files from the heel to the point, which is the only correct way. The file is supposed to be horizontal to the perpendicular of the side of saw, and on an angle of about 45° longitudinally with the length, measuring from file line toward heel.

Fig. 10 is a five and a half cross-cut saw showing the same amount of fleam front and back; this saw is best suited for work in soft wood, and where rapid, rather than fine work is required. *A* shows the position of the file, *B* an exaggerated view of shape of point, and *C* the shape of point.

Fig. 11 is a seven point saw for medium hard woods, illustrated in same manner as Fig. 10. This tooth has less fleam on the back, which gives a shorter bevel to point, as at *C*. Fig. 12 is a still finer saw, having ten points to the inch. This saw has no fleam on back, the result being very noticeable at *C* and *B*. This style of point is for hard wood.

It will be seen that the bevel on the front of teeth in Figs. 10, 11 and 12 is the same, but the bevel of the point looking the length of saw is quite different, consequent upon the difference in the angles of the backs. CONCLUDED IN JANUARY NUMBER.

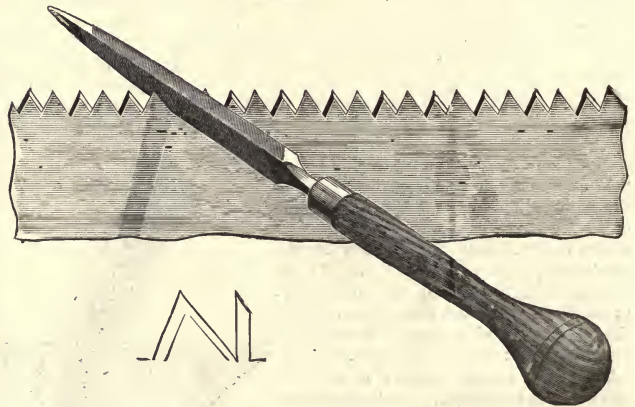

FIG. 11.

The wood used in lead-pencil making must be close and straight-grained, soft so that it can readily be whittled, and capable of taking a good polish. No better wood has been found than the red cedar, a native of the United States, a durable compact, and fragrant wood, which today is used almost exclusively by pencil makers the world over. The best quality is obtained from the southern states, Florida and Alabama in particular.

The Correspondence Column is omitted from this number owing to lack of space.

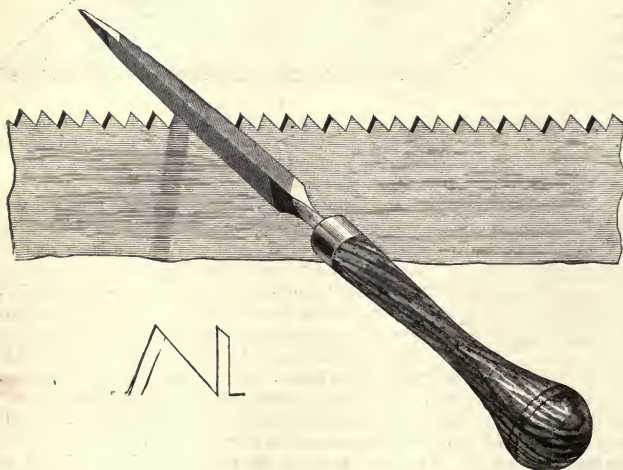

FIG. 12.

JUNIOR DEPARTMENT

For the Instruction and Information of Younger Readers.

INDUCTION COIL EXPERIMENTS FOR BEGINNERS.

I do not think it need be supposed that even an amateur will buy or make a 4" or 6" coil, without having some set purpose in view, or a good idea of the uses to which he intends to put the induction coil

There are many amateurs who build or buy coils, giving a spark ranging from 1-4" to 1" with very little notion of the possibilities of such coils, and it is for these readers that I describe the following simple experiments:—A small coil experiment, which is one of the most striking and often the only one which beginners perform for the edification of themselves and friends, is a display of vacuum tubes. Current from the secondary of a 1-4" spark coil will light up tubes 6" or 8" long; but the best effects are obtained from a little larger coil than this. It may, perhaps, be better to explain here that in all experiments with high-tension electricity the operator must be most particular not to be included in the path of discharge, or the result may be harmful.

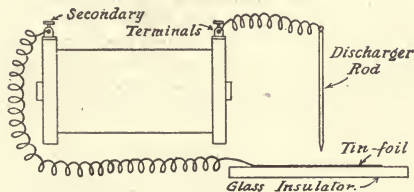

FIG. 1.

A very fine experiment with a small vacuum tube and say a 1-4" spark coil, is the following:—Put the coil in action, discharging sparks as usual. Take a vacuum tube in one hand, and place the loop at the end in contact with the positive discharge rod; then gradually bring the index finger of the other hand towards the other discharger rod terminal; but on *no account* touch it, and the tube will be seen to be lighted up. Another variation with these Geissler tubes is to fasten them securely in a vacuum tube rotator. Current is conveyed to the tube while the rotator is in action, giving the effect of a wheel of light. Do not use small tubes with large coils giving over 1" spark unless the platinum electrodes are very thick; but tubes of more than 6" are fairly safe on larger coils, though no definite rules can be given.

Here are a few of the more interesting experiments with the spark itself. Place a sheet of tinfoil, or a piece of glass, in contact with one of the secondary terminals. Bend a short length of wire attached to the other terminal until it is within striking distance of the tinfoil plate (Fig. 1.) Set the coil in action, and you will see the stream of sparks break into several little rays and wind across the tinfoil. This class of experiment is very numerous, and the amateur, when once started, will have much enjoyment from experi-

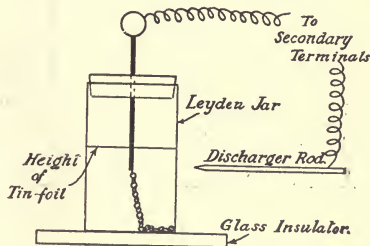

FIG. 2.

menting with the spark itself. Deflagration experiments are easy. Get two short lengths of iron wire, and put one in each end of the discharging rods. Arrange the distance between so that the iron becomes white hot when the coil is in use. Bright sparks will be emitted from the white hot metal. Try this with different metals, and notice the difference in the color with using different wires. Let the spark pass through fine metal filings placed on an insulator. Some of the filings will be fired by the spark, and the latter in its zig-zag path will be colored according to whatever metal was used. Tip each discharger point with a little oil, and bring them very close together. The spark will be a vivid green. Lycopodium powder on cotton wool, if placed in the way of the spark, is fired; and the same thing can be done with gunpowder in very small quantities.

These will no doubt serve to start the amateur on the road to discovering many more such experiments for himself. All experiments performable with a Wimshurst machine can be done on an induction coil. Firstly, I will show how to charge a Leyden jar from a coil. Put the jar on a piece of glass, or similarly good insulator (Fig. 2.) Connect the knob of the jar to one of the discharger points, and let the other point be held at a little distance from the outer covering of the jar. When the coil is put in action a static charge of elec-

tricity will be given to the jar. This leads us to another little variation. Set the coil ready for sparking, and in addition, attach a wire from one terminal of the secondary to the knob of the jar, and a wire from the other terminal to the outer covering. When the coil is discharging sparks, the jar receives a static charge, and forming as it does an extra condenser, it

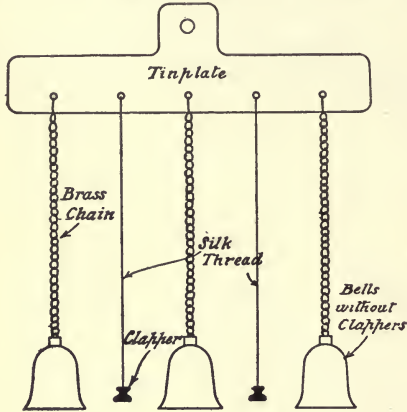

FIG. 3

discharges itself across the spark-gap together with the ordinary coil discharge. The length of the spark is thus increased.

The following is an experiment known as the "Chimes," the construction of which is shown in Fig. 3. The centre bell is connected to the ground by a

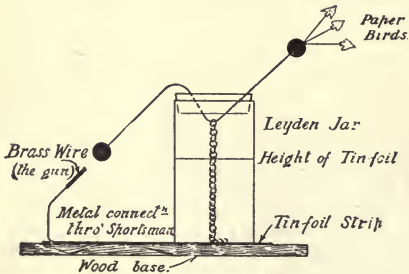

FIG. 4.

chain from its centre touching the table. When a charge is given this apparatus, the clappers are attracted to the outer bells, which are charged with electricity. When the clappers touch, they too are charged, and are repelled with enough force to enable them to both strike the centre bell. This discharges them again, and the movement is repeated.

Another may be styled the "Birds and Sportsman" experiment. On a small base is erected a Leyden jar of the kind I have depicted. A strip of tinfoil is fastened along the baseboard, and the jar rests on this (Fig. 4.) The birds are of paper, and fastened to one brass ball with a piece of thin cotton. The sportsman's gun is a piece of brass wire, and is connected with the tinfoil on the base. The gun points to the other brass ball. When the jar is charged the birds will fly apart by repulsion, and remain flying for a short time. Now gradually push the sportsman nearer until his gun is very near the ball. This will discharge the jar with a loud crack, and the birds will fall. Finally, I think every amateur electrician will find that there is hardly any other instrument which he will obtain that will give such lasting pleasure as an induction coil.

Model Engineer, London.

HANDY RECEIPTS.

TO CLEAN LENSES.

Clean lenses as rarely as possible. Use old linen or a very soft chamois skin, but never use silk. If greasy, wet with a weak solution of cooking soda, and wipe dry with the cloth or chamois.

FLEMISH OR DARK OAK STAIN.

First stain the wood with any thin black stain; the following being easily made:—Sulphate of iron, 2 oz. extract of logwood, 1-2 lb. carbonate of iron, 1 oz. vinegar, 1 quart. Boil over a slow fire for two or three hours and strain through a cloth. Then apply a coat of antique oak stain, made as follows:—Raw sienna is thinned with linseed oil and turpentine to the right consistency for the depth of color desired. Ivory black may be added if a very dark stain is wanted. If a filler is needed, use oak filler.

WATERPROOFING SHOES.

Castor oil, well rubbed into the soles, seams and uppers of shoes will prevent to a large extent moisture from rain or snow from working through, and allow shoes to be polished with blacking. It is well however, to polish with blacking before applying the oil. Preparations with gums such as copal, eventually harden and cause cracks.

Prof. Alexander Graham Bell recently gave a correspondent of the *Daily Telegraph* an idea of his work on the problem of aerial flight. He has spent years in study, and many thousands of dollars, in the effort to invent a means of flying. When asked if he thought that man would ever be able to fly, the professor replied: "I can see no reason why anyone who has noted the flight of birds can for one moment doubt the possibility of flight by bodies specifically heavier than the air."

AMATEUR WORK

A MONTHLY MAGAZINE OF THE USEFUL ARTS AND SCIENCES

Vol. III. No. 3.

BOSTON, JANUARY, 1904.

One Dollar a Year.

A MAGIC LANTERN

For the Home or Small Halls.

As a means of pleasant and interesting entertainment, a well made magic lantern possesses many attractions to the amateur, and this is especially true if several friends also have lanterns, the exchanging of slides serving to give sufficient variety to sustain interest through many evenings. In addition, the multitude of slides which may be hired or purchased, open up a wide field, limited only by the capacity of one's pocket book or inclinations.

The lantern here described, while made for home use, requires no change, other than the objective, to adapt it for large halls, and two of them with a dissolving attachment would equal in worth that of an expensive lantern. The sizes of the condenser and objective as given in this lantern can be changed, if necessary, to other approximate sizes, and the reader is advised to purchase these before constructing the lantern, that he may know their exact dimensions and work accordingly. These sizes specified were purchased of a dealer over stocked on these sizes and because of a substantial reduction from regular prices. Readers in large cities are advised to visit the different optical and photographic supply houses, as by so doing they may be equally fortunate in securing a bargain. For house use, a wide angle or small lens is necessary, as the size of the picture thrown on the screen depends upon the size of lens and distance between lens and screen as shown in the following table, giving the various sizes of pictures to be had with

different objectives at varying distances from the screen when three-inch slide is used.

SIZES OF LENSES	Distance from Screen.					
	10 ft.	20 ft.	30 ft.	40 ft.	50 ft.	60 ft.
Wide Angle	6 2-3	13 1-3				
1 5-8 inches	5	10	15	20		
1 7-8 "	4	8	12	16	20	24
2 1-4 "		6	9	12	15	18
2 1-2 "			7 1-2	10	12 1-2	15
3 "			6	8	10	12

The several parts of the lantern include the objective or lens, and holder for same, focusing tube, slide box and frame, condenser and holder, burner and hood and adjustable framework, which will be separately described. The frame is made almost entirely of brass castings and tubing, the patterns for the castings being easily made from pine.

The shape and dimensions of the objective support are shown in Fig. 1. The casting *A* is finished with a file and fine emery cloth. The holes *a* are $\frac{1}{4}$ " diameter, pieces of 22 guage tubing 8" long, being secured therein at one end by soldering. The guides *C* are made from a piece of $\frac{3}{8}$ " square brass tubing 5" long, which has been split centrally, the lower ends being double riveted to the casting *A*. The slots *b*, $3'' \times \frac{3}{16}''$ are worked out with a small flat file, after drilling holes at each end with a hand drill and sawing down with a hack or heavy fret saw. The objective has a threaded flange which is mounted centrally upon the block *D*, Fig. 2, made of mahogany and nicely polished. It is 5" square

and $\frac{3}{8}$ " thick, the sides fitting into the guides *C*, being cut down with a rabbet plane to an easy fit. At the centre of these sides, brass pieces *d*, 2" long, $\frac{5}{8}$ " wide and $\frac{1}{16}$ " thick are let in, after drilling and tapping holes in the centre for $\frac{3}{16}$ " knurled head brass set screws. These are needed to adjust the lens to the correct position to throw the picture evenly on the screen.

The usually focussing arrangement of a lantern is a bellows much like those used in cameras, but this requiring considerable time to make and the use of materials not easily obtained, a telescopic tube was used, this being made from a one pound coffee tin for the outer tube and the inner one from a re-soldered tomato can. The latter was heated along the seams over a furnace fire until they separated, then cleaned and re-soldered to an easy sliding fit to the other can. This gives ample adjustment. The condenser cell was made in the same way, with the exception that the case of an old alarm clock was used for one section, and a coffee tin for the other, the length of each having to be cut down to the dimensions given later. The ends of the cans were cut out to give a flange about $\frac{3}{8}$ " wide. First mark with dividers, if an old pair is available, sharpen one point and use to cut through by continued working around the line. With a lathe, mount on face plate with wood backing and cut with hand tool. A coat of black enamel paint will give a good finish. One tube is attached to the piece *D* by four short round head screws, the heads of which lap over the flange, the location being marked by striking a circle with dividers after the frame is completed so that the parts will not bind anywhere. The other tube is riveted to the slide holder support *S*, Fig. 3. Suitable rivets are made by cutting off the ends of brass escutcheon pins, filing the ends smooth. The heads are on the inside of the tube, held during riveting against the top end of a cold chisel or piece of bar iron held in a vise.

The slide holder support is made of a strip of sheet aluminum, 16 gauge or thereabouts, $14 \frac{1}{4}$ " x 6". The faces are 6" square, the ends $\frac{1}{2}$ " and the lap for the joint $\frac{1}{2}$ ". The turns are marked with a scratch point then bent carefully to shape. If convenient, take to a tin shop and have the bending done on a machine. The circular open-

ings in each face are cut out before bending. This can also be done at the tin shops at little or no expense, and a better job secured than ordinarily if done by the reader. The size of the holes cannot be determined exactly until the condenser cell is completed, so this part should be left until after making the condenser. A piece of $\frac{1}{8}$ " tubing *S'*, 4" long is attached to each lower rear corner of the holder, by first sweating on strips of brass *S''*, the ends of which are turned outward to form lugs for riveting to the holder, as owing to the nature of aluminum, they cannot be soldered to it. The final length of these pieces is found when the frame is completed, they are then cut off to bring the rear hole in the holder in line with the condenser.

The remaining part of the frame is now to be made. Three brass castings *F*, *F''*, *F'''* Figs. 4 and 6, are required. These are finished by filing and with fine emery cloth. Holes are then drilled for the $\frac{3}{16}$ " brass tubing *G*, 22 gauge which must be in exact line with the tubes in the holes in *A*, as these tubes slide within each other. The rods *G* are 5" long, and are sweated into the holes drilled in *F* and *F''*. Other $\frac{3}{16}$ " holes are then drilled in all these pieces *F* for the rods *G'* which are 12" long. These are sweated in, but care should be taken to have the brass casting *H*, Fig. 6, finished, fitted and in place before this is done. This casting has $\frac{3}{16}$ " holes drilled in line with the tubes *G'* and slides freely thereon. Two pieces of $\frac{1}{2}$ " brass tubing *h*, 4" long, are fitted to holes drilled in *H* and spaced to fit the pieces of $\frac{3}{16}$ " tube *S'* on the slide frame holder. Knurled head set screws *j* are fitted to each end of *H* and also to *F'* as shown at *f* Fig. 5, for fastening the rods *B*.

The condenser cell is made as previously mentioned for the focussing tube. The size is regulated by that of the condensing lenses plano-convex lenses $4 \frac{1}{8}$ " diameter being used in this lantern, as the same were obtained from an over stocked dealer at a very low price. The usual sizes vary from $4 \frac{1}{8}$ " to $4 \frac{1}{2}$ " diameter, the smaller ones being quite as good for this lantern as the larger, and the reader will find it to his advantage to look up the lenses, and see what may be obtainable at less than usual prices. The convex faces of the lens are together with only about $\frac{1}{8}$ "

to $\frac{1}{4}$ " space between. The tubes are $1\frac{3}{4}$ " long, with narrow flanges not over $\frac{1}{8}$ " wide on the outside. The lenses are kept in position by punching V shaped lugs in three or four places, the points being bent inward after the lenses are in place.

The body of the lantern is made of sheet aluminum, about 24 guage, this metal having properties which peculiarly adapt it for that purpose;

of the rivet should project for heading up. The shape of the body is practically that of a box 8" long, 7" high and 7" wide, the top being curved as shown. One strip is used for the sides, top and bottom, a piece 28" long and 8" wide being required, the lap joint being made at one of the lower corners. Ten $\frac{1}{8}$ " holes are punched in the bottom for admitting air.

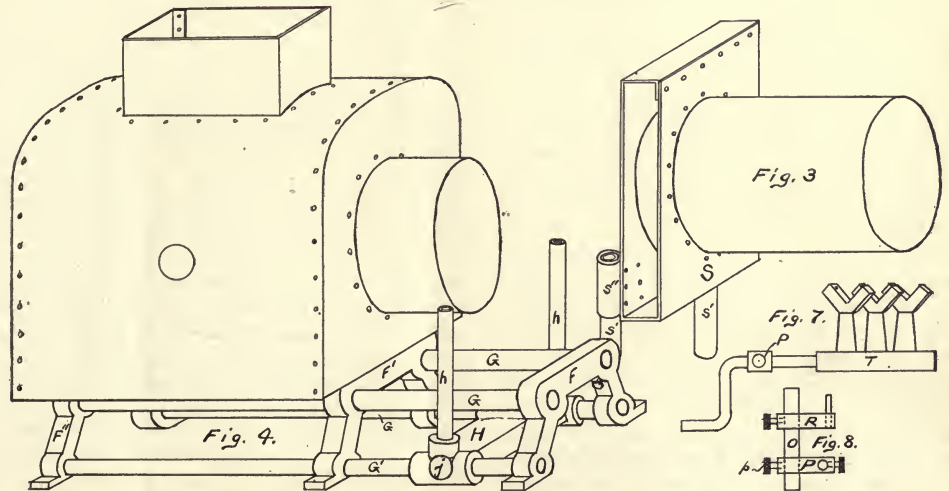
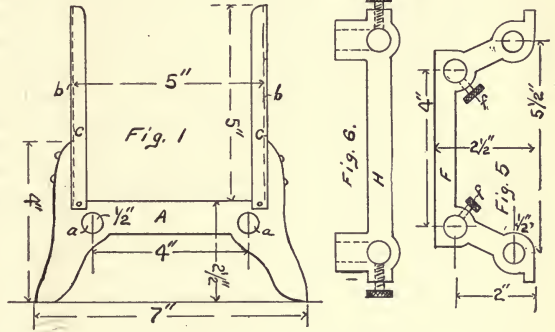
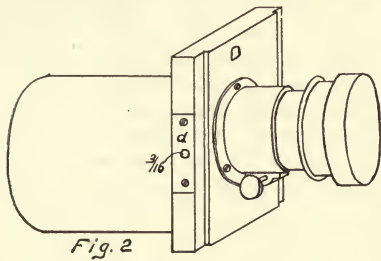

it radiates heat so rapidly that the hot flame of the burners does not heat it to near the extent it would brass or Russian iron. The sheet size is 6 ft. long, 12" wide, a piece this size 24 guage, weighing about $1\frac{3}{4}$ pounds and sold at about 75 cents per pound. As it cannot well be soldered, joints are made by riveting, the rivets being made from brass escutcheon pins, as previously mentioned, the heads inside. But little

The front or condenser end has a $\frac{1}{2}$ " flange all around fitting inside for riveting, and a hole in the centre about $4\frac{1}{4}$ " diameter, to which is riveted a flange 1" wide for holding the condenser cell. This flange, also made of aluminum, has lugs all around the inner edge for riveting to the end. The rear end has a large door with hinge on the right side, made by bending over lugs left on the door, and also the piece cut out for same.

Smaller lugs are left on the left side for bending over to hold a piece of wire with an eye end for fastening. A hole 4" long and 2" wide is cut in the centre of the top. A 2" flange is then fitted to this hole by riveting. A chimney 8" high is fitted to the outside of this flange; a monitor top is fitted to the chimney. The chimney is not fastened, as it is removed when not in use to reduce the space required for packing away. The body is fastened to the castings F' and F'' by four round head machine screws, holes being drilled and tapped for same.

The burner is made as follows:—To the centre of a piece of $\frac{1}{2}$ " square brass tubing T , Fig. 7, 4" long is soldered three acetylene burners, after drilling $\frac{1}{4}$ " holes for admitting the gas from tube to burners. The outer end of the tube is then closed by turning down a section of the top or burner side, after cutting away with a hack saw the other three sides. This is done to prevent having a soldered joint of the upper or hotter side. The joint is well sealed with hard solder, and should be a good job to avoid leaking. If the reader does not feel equal to doing this have it done by a plumber, as it will cost but little. The other end is then closed in the same way, making the finished tube 3" long, and a piece of $\frac{1}{4}$ " brass tube 6" long, fitted thereto by sweating after drilling a hole to admit the end of same. The arms of the burners are at an angle of 45° with the tube.

The burner and reflector holder consists of a piece of $\frac{1}{2}$ " brass tubing O , Fig. 8, 3" long fitted to a hole drilled in the top of the casting F'' about 1" to the left of the centre. The exact position is found after the burner and holder are completed, the object being to bring burner and reflector exactly in line with the centre of the condenser. A piece of brass rod P 1 $\frac{1}{4}$ " x $\frac{3}{8}$ " x $\frac{5}{8}$ " is drilled at one end for the tube O , and fitted with a set screw p . A $\frac{1}{4}$ " hole is drilled at the other end for the tube of the burner, and a set screw fitted at that end. The reflector holder R is a piece of brass rod 2" x $\frac{3}{8}$ " x $\frac{5}{8}$ " drilled at one end for the tube O , and fitted with a set screw. At the other end a piece of $\frac{1}{8}$ " round brass rod is fitted to a vertical hole, and also fits a hole to be found on the back of metal reflectors. One about 4" diameters is a good size. A piece may have

to be cut out at the bottom to fit around the burner tube. The burner tube after being put through the holder P is bent downward and carried through a hole in the back end of the body. A $\frac{1}{4}$ " lever handle air cock is then soldered to the end, and the rubber tubing from the generator pushed well into the end of the cock. This method of fitting burner and reflector enables accurate adjustment to be made, a very important feature as will be learned when using the lantern. A 1" hole is cut on either side of the lantern at about the centre, and fitted with pieces of ruby glass, giving a chance to view the flame while using the lantern and without opening the door.

The lantern is now complete with the exception of the slide holder, which together with the acetylene generator, slides and coloring of same, will be described in subsequent numbers of this magazine.

NOTE:—The castings, tubing and other parts necessary to make this lantern will be offered as a premium should a sufficient number of readers make request to have this done.

A comparison of gasoline and alcohol with regard to their relative heating value is possible after recent Austrian experiments. For motive purposes a pair of nominal 8 H. P. engines, one designed for alcohol and the other for gasoline, were compared. The gasoline had a specific gravity of 0.7 and a calorific value of 7,700 calories per litre; the consumption per horse-power was 340 grammes. The denatured alcohol (methylated spirit) was of 90 per cent. strength, and had a calorific value of 4,900 calories per litre; its consumption was 373.5 grammes per horse power. The efficiencies were, therefore, 16.5 per cent. for the gasoline, and 28 per cent. for the alcohol.

Thomas A Edison, the inventor, is credited with having perfected a new electrical generator which will revolutionise the methods of producing electricity. The generator derives its power from a new kind of fuel; which Mr. Edison is keeping secret. Three pounds of it is said to be sufficient to secure enough electricity to light a house or run an automobile for a day.

MICROSCOPY FOR AMATEURS.

S. E. DOWDY. M. P. S.

III. OBJECTIVES AND EYE-PIECES.

It now only remains to describe the objectives and eyepieces. Microscope lenses, objectives, or powers as they are variously termed, consist of combinations of lenses of varying magnifying power, mounted in short brass tubes furnished with a standard size screw for attaching to the lower end of the microscope body-tube. The gauge recommended by the Royal Microscopical Society is the one almost universally adopted by makers nowadays, and in no case should an instrument be obtained having any other gauge for its lenses.

There is little fear of getting such an instrument new; but some of the older makers might differ in this respect. To distinguish them from one another and indirectly to indicate their magnifying power, English lenses are designated in inches and parts of an inch, Continental ones by millimetres. For instance; an English lens might be a $\frac{1}{4}$ " , $\frac{1}{8}$ " , and so on, down to $\frac{1}{40}$ " or $\frac{1}{50}$ of an inch, whereas a lens by a German maker might be a 24, 12, or 6 millimetre, as the case might be.

The beginner is naturally apt to fall into the error that, because a lens is called, say a 1" , that it will focus at exactly that distance from an object. This is not necessarily the case, the terms applying to the focus of a single lens of the same magnifying power. The objective may be an optical combination of half a dozen lenses, the front one of which may and probably does focus much nearer to the object than the objective's designation would imply.

The value and cost of an objective is partly dependent upon its magnifying power, but more so upon what is termed its numerical or angular aperture. It is difficult to explain the meaning of this term in a word or two, but briefly it refers to the angle at which the rays of light from an object can enter the objective to form a well corrected image. This is not dependent on the size of the front lens of the objective, as a beginner might expect, but is a question of the curva-

ture of the various lenses making up the combination. A lens of wide aperture, providing the proper corrections have been made in it, will admit more light and show more detail than a narrow apertured lens of the same magnifying power. It is therefore superior to the latter, but owing to increased skill and work required for its manufacture, is much more expensive. Students' lenses are now made with larger numerical apertures than they used to be, owing to a more general recognition of the fact that on the aperture depends the resolving power and definition of the lens, providing workmanship is good. The bearing that aperture has on the performance of a lens will be noted, when we come to the testing of lenses, as it is rather an important point. We now come to the *eyepieces*.

Those that the student will require are what are known as Huyghenian, consisting of a couple of plano-convex lenses, mounted in a short metal tube. The lower lens is termed the field lens, the upper the eye lens. Eyepieces are constructed of various magnifying powers from about 4 diameters up to 18 or 20. Low power eyepieces, which are the most useful, are sometimes called shallow, those of higher power, deep eyepieces. A student's stand is generally supplied with one low-power eye piece, magnifying four or five diameters, but an extra one of rather high power is well worth obtaining, as they can be obtained for \$5 each.

It is of little use for the beginner to buy an eye piece of higher power than one magnifying about ten diameters, for the following reason:—In observing an object with a compound microscope, the image formed by the objective is further magnified by the eyepiece. Any imperfections, therefore, in this primary image are accentuated by the eyepiece in proportion to its magnifying power. Carefully corrected lenses of wide aperture will stand deep eyepiecing without appreciable deterioration of the image; but students

lenses, though giving excellent results with low power eyepieces, break down under high power ones. This is the reason why, in testing microscope lenses, the appearance of the image is noted under a deep eyepiece.

We have now briefly enumerated the leading features of a student's microscope, and the novice is advised to make himself acquainted with the specific purpose of each part of his instrument before proceeding to do work with it. Each observer has different methods of working, but it is he who has the better knowledge of the capabilities of his microscope who will make the best microscopist.

The next thing after, or better still, the first thing before purchasing a microscope is to test its objectives, eyepieces, and adjustments. Take nothing for granted, but carefully see that each adjustment is efficient, and above all things, that the lenses are of good quality. For actual working, daylight, for several reasons is preferable; but for testing lenses, artificial illumination admits of more control, and will serve our purpose better. For providing the necessary light a small kerosene lamp will be required, any hand lamp with a $\frac{3}{8}$ " wick will do. The microscope should be placed on a steady table or bench, with the lamp on the left-hand side, and slightly in advance of the instrument. The probability is, if the microscope has been purchased complete, that it will possess a couple of objectives, a 1" or $\frac{3}{4}$ " and a higher power of from 50 to 500 diameter may be obtained.

We will now start with the low-power lens, as it is easier to use. Screw it into the lower end of the body-tube, and place the low-power eyepiece in the upper end of the tube. Now manipulate the mirror so that a beam of light is thrown up through the stage aperture into the field of the lens. On looking through the eyepiece, a brilliant circle of light should be seen, this being called the field. If unevenly illuminated, a fresh adjustment of the mirror, or a slight alteration in the position of the lamp will be necessary. If the microscope is fitted with an Abbe substage condenser, the top lens of condenser should be first removed before adjusting the light. It is, however, with the higher powers that the substage condenser comes in useful, so that a few words will be said with regard to the method of

using it when we are testing the high power lens. Now remove the eyepiece and look down the tube of the microscope, and see how much light is entering the objective. If full of light, rotate the diaphragm under the stage until the cone of light from the mirror is cut down until it illuminates about two-thirds of the back lens of the objective; then replace the eyepiece. We shall now require a test object, which is one possessing fine enough markings or detail to require a good lens to show them well. Most opticians supply suitable objects already mounted, such as the tongue of the blow-fly, for low powers, and diatoms and insect scales for high power lenses. As recourse to an optician is not always available, we will select an object readily obtainable, at least, during a good part of the year, easily mounted, and furnishing a good test of the capabilities of a lens. I am referring to the wing of the common house fly. After killing the insect, detach one of the wings and place it on a thin 3" x 1" glass slide, cover it with a thin square cover glass, which should be held down by a couple of strips of postage stamp paper.

The object is now ready for examination, the slide can therefore be placed on the microscope stage, with the object in the centre of stage aperture. Now use the coarse adjustment by either sliding the body tube up or down or lightly rotating the milled heads provided for the purpose. When the image is coming to a focus, note the working of the coarse adjustment. A good rack-and-pinion adjustment should give a smooth, gliding motion free from jerks, and on looking at the object no displacement to one side should be noticed on altering the focus. When a sharp focus has been obtained, carefully note the appearance of the object, which will present the appearance of a delicate membrane studded with minute hairs and traversed with thickenings of the membrane, which thus form a framework. A fringe of very fine hairs will be found edging the wing, and particular attention should be directed to these. With a good lens each hair will stand out perfectly sharp and clear, with no trace of a colored fringe surrounding it, and the hairs on one side of the field of view will be in as sharp focus as those on the opposite side. Now pull out the draw tube, if the microscope is fitted with one, and re-focus. Increased magnification

is the result, but the definition will probably fall off a bit, partly due to the lens probably being corrected for a short tube length. Push in the draw tube and substitute the high power eyepiece, and note the effect. A less brilliant image will be the first noticeable alteration, also, of course, an enlargement of the image. No fur-

ther detail will be shown, but we have now to note what appearance this enlarged detail presents. If the hairs on the edge of the wing still present a perfectly clear, sharp cut outline, and are free from color, the lens may be relied on for any work the student is likely to require it for.

English Mechanic.

A SMALL TABLE.

JOHN F. ADAMS.

This small table was made to use up some odd pieces of wood, but has proved so very convenient that a description is here given. The top is 22" x 32" x $\frac{3}{8}$ ", glued up from two pieces of whitewood. The legs are 30" x 2 $\frac{3}{4}$ " x 1 $\frac{3}{4}$ ", spruce joist in this case, planed up smooth. The larger pieces under the top are 26" x 3" x $\frac{1}{8}$ ", the shorter one 14 $\frac{1}{2}$ " x 3" x $\frac{1}{8}$ ". This allows $\frac{3}{4}$ " on each end for tenons to fit mortises cut in the tops of the legs, spaced so as to bring the outer edges $\frac{3}{8}$ " from the outer sides of the legs. The mortises were made full size of the cross pieces, but a better way is to cut tenons with a $\frac{3}{16}$ " shoulder, and mortises to match, the table then being more rigid.

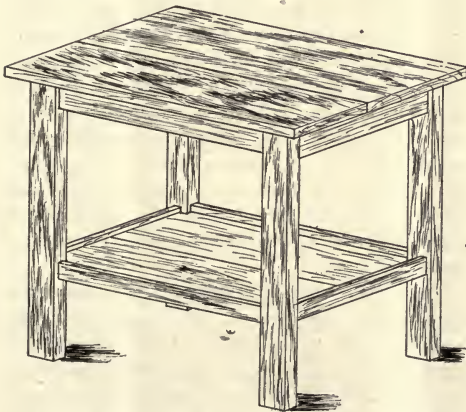

The cross pieces for the shelf are of the same lengths as those above but are 2" wide, mortises being cut in the legs so as to bring the under side of these pieces 9" from the floor. The joints

were glued, and pinned with dowels made from meat skewers. It may be well to state that gluing in cold weather should be done in a warm room, the stock to be glued having been warmed to at least the temperature of the room.

The shelf is also glued up, and when thoroughly dry, cut to fit around the legs, then nailed through the cross pieces. The top is attached to the upper cross pieces by eight screws, $\frac{1}{2}$ " holes being bored to a depth of 2" and screw holes the rest of the way. These holes should be bored before finally setting up the table, as there is hardly room for a bit stock and bit between the cross pieces when put together.

After sand-papering, weathered oak stain was applied, this dark stain being particularly suitable for such a table. It was thinned out a little with spirits to bring out the grain a little, the woods used having but little markings. A coat of thin varnish completed the finish.

The Edison commercial phonograph is said to have been so far perfected that it is practicable for taking court testimony and for constant employment in the office, one record being capable of taking several dictated letters. It can be shaved 175 times, making it as cheap as letter paper.

In a paper read before the German Physical Society, Mr. H. Starke describes experiments on cathode rays, which confirm the idea that the apparent mass of the flying corpuscles is purely electrical.

PHOTOGRAPHY.

AN ELECTRICALLY OPERATED FLASH-LAMP.

The particular advantages of this flash lamp are;— It may be operated from any location, and at any time desired by the operator without others having previous notice of when the lamp will flash. It is thus possible for the operator to be included in a group, and the peculiar contraction of the eyes so characteristic of most flash-light pictures is avoided, as any opportune moment can be utilized for the flash.

The novel feature of this lamp is the use of an electric magnet for releasing the trigger, the latter working much after the fashion of a mouse trap. The horseshoe magnet *M* can be taken from an electric bell. It is mounted upon a wooden base *B* which measures 12" long, 5" wide and $\frac{3}{4}$ " thick. A hole will be found in the centre of the bar connecting the two coils of the magnet. Through this hole put a small screw attracting the magnet to the frame holding the arm *A*. This

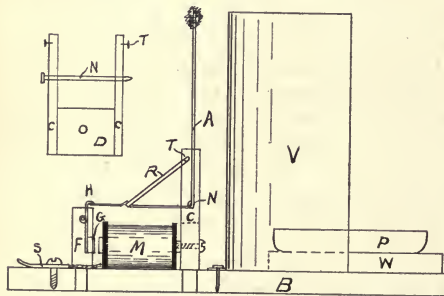

frame is made of two pieces *C*, 3" long, $\frac{3}{8}$ " wide and $\frac{1}{4}$ " thick, nailed to the piece *D* which is 1 $\frac{1}{2}$ " long, 1 $\frac{1}{4}$ " high and $\frac{3}{8}$ " thick. It is attached to the base board by two screws of small gauge put through from the under side of the latter. Holes for the wire nail *N* are bored in the pieces *C*, 2" from the bottom ends. Two small tacks *T* are driven into the upper ends of *C*, to which fasten a light rubber band *R*, which when slightly stretched will engage in the notch in the lower part of the arm *A*.

The brass or iron wire arm *A* is 2 $\frac{3}{4}$ " long on the horizontal section, and 4 $\frac{3}{4}$ " long on the vertical. In cutting, also allow for two turns to go around the nail *N* with a loose fit, and a turn at the upper end to hold a tuft of asbestos wool or cotton wicking. The end at the trigger is hammered out flat and then filed smooth, but no bevel on the top side. A notch for the rubber band is bent in the centre of the horizontal part as shown.

The trigger is made of the armature *G* of soft iron, also taken from the electric bell. The hammer of the bell is an extension of this armature. The surplus pieces are removed as only the armature is needed. A piece of iron wire *H* is fitted to a hole drilled in the centre; two turns are made $\frac{5}{8}$ " above the armature to fit around a nail shaft as before described, and $\frac{1}{8}$ " of the upper end is bent at right angles, $\frac{5}{8}$ " above the centre turns. Two supports *F* are 2 $\frac{1}{2}$ " high, $\frac{3}{8}$ " wide and $\frac{1}{4}$ " thick, $\frac{3}{4}$ " of the lower ends being cut down to fit $\frac{1}{4}$ " holes in the base bored to receive them. Holes are bored in these supports 1 $\frac{3}{8}$ " above the base for the nail *O*, but this should not be done until all the parts described are in position so that the trigger may be located in just the right place. The two wires from the magnet are each carried to connecting springs *S* made of short pieces of spring brass, a hole being bored in one end to receive a round head brass screw under the head of which is carried a wire from the magnet. The ends of other wires connecting battery and push button can be readily placed under the ends of these springs when connecting up for the work.

The powder pan *P* is made of tin, (that taken from an old preserve can will serve) and is 8" long, 3" wide and $\frac{1}{4}$ " deep. It is attached to a block of wood *W* $\frac{1}{2}$ " thick, by a round head screw located on one side so that it may be turned to be in line with the base board when not in use. The block *W* is curved on the rear side to an arc fitting the reflector *V*. The reflector is made from a bright piece of tin from a fresh preserve

can, and is 6" high, and 8" long. On the lower edge three lugs $\frac{1}{2}$ " wide and long are left, one in the centre and one near each end, which are turned toward the front and are pushed between the block *W* and the base, holding the reflector upright when in use and yet allowing easy removal for packing up. At the centre of the reflector a slot $\frac{1}{2}$ " wide is cut from the top nearly to the bottom, for the arm *A* to drop through.

To operate, the terminals *S* are connected by flexible wire to battery and push button as follows; run a wire from one terminal *S* to zinc of a dry cell; from the carbon of cell run wire to push button; from the other terminal *S* run wire to push button. Put the flash power on the tray *P*

spreading it along in a line so it will not all fire at once, but make a running flash. The tuft of asbestos on the arm *A* being wet with alcohol, the trigger is set and the alcohol lighted. By pressing on the push button, the circuit will be completed, the magnet will attract the armature *G*, releasing the arm, the rubber band will pull the arm over so that the weight of the upper part will cause it to continue falling until it reaches the powder and flashes it.

The length of the connecting wires is as may be desired by the operator. If one dry cell does not furnish sufficient current to attract the armature use two. A few trials without powder will enable any needed adjustments to be made.

A MODEL STEAM TURBINE.

W. HALCOT HINGSTON.

The steam turbine, when used as the propelling machinery of a model steamer, has several distinct advantages over engines of the reciprocating type. When designing machinery for model steamers the chief difficulties are;—The small size of the engine room, the difficulty of making sufficiently powerful machinery light enough for the displacement, and the further difficulty of keeping the centre of gravity of the said machinery sufficiently low down to make the boat seaworthy. The steam turbine gets over all these difficulties, it being small, light for its power, and it can be put at the very bottom of the boat.

There are two types of steam turbine which have proved specially successful in actual practice (i. e., not model work) these being;—The De Laval (jet type), the Parsons (parallel flow.) In building a model, one or the other of these types may be used, but in a modified form; and as the Parsons turbine would make a very difficult and complicated model, a modified type of the De Laval turbine has therefore been chosen by the writer. Of course, a steam turbine can be used for many other purposes, but its advantages are more marked in model steamer work, and, therefore, I shall endeavor to explain how

one can be constructed suitable for a boat about 5 ft. long, which seems to be the most favored size amongst model makers.

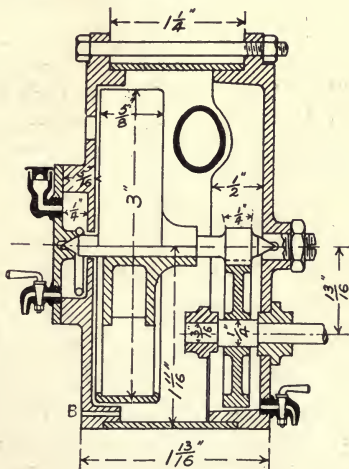

FIG. 2.

The De Laval turbine is an impact turbine, and consists essentially of a wheel carrying a number of suitably shaped vanes, on which steam

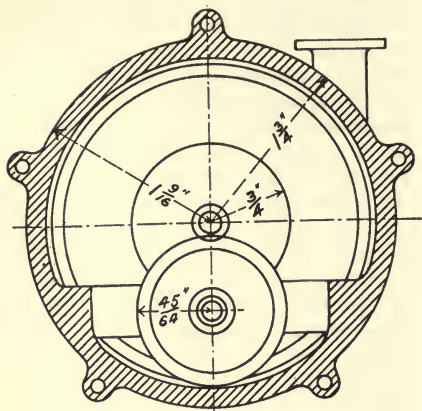

FIG. 2.—CROSS SECTION OF TURBINE.

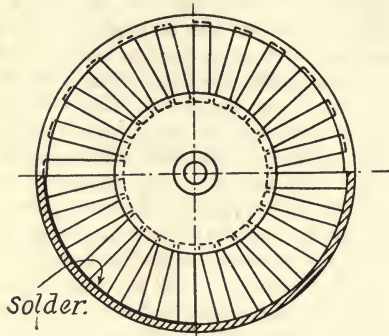

FIG. 4.—ELEVATION OF WHEEL.

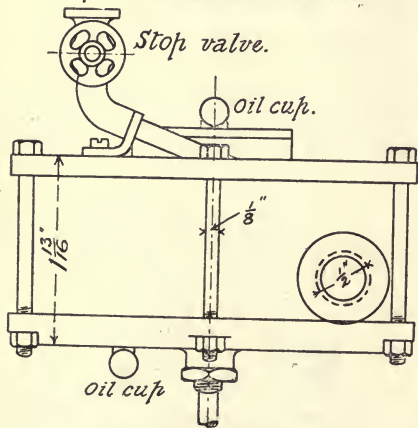

FIG. 3.—PLAN OF TURBINE.

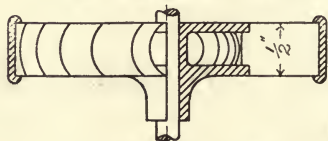
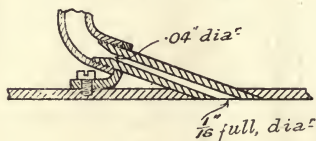

FIG. 5.—PLAN OF WHEEL.



DETAIL OF NOZZLE.

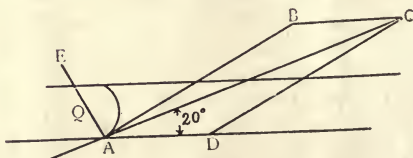

FIG. 6.

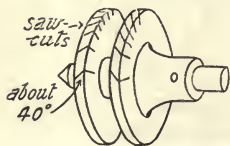
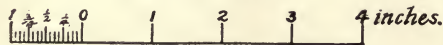

FIG. 7.—BOSS OF WHEEL.



FIG. 8.—MOULDS FOR CURVING THE BLADES.



DETAILS OF MODEL STEAM TURBINE
(DE LAVAL TYPE.)

BY W. HALCOT HINGSTON.

impinges from one or more nozzles. As nothing definite is known about the power which a model turbine of any particular size will develop, the governing factor must be the amount of steam with which it can be supplied. A model steamer of about 5 ft. in length can easily be fitted with a boiler having from 100 to 150 sq. in. of heating surface. Assuming, therefore, that we have a boiler with 120 sq. in. heating surface, working at 30 lbs. per sq. in, about 1.2 cubic in. of water will be evaporated per minute, which will give 686.4 cubic in. of steam at 30 lbs. pressure.

The total jet area which the boiler will supply can approximately be found from Rankine's formula:—

$$w = \frac{6ap}{7}$$

w = weight in lbs. of steam at absolute pressure

a = area in square inches of jet

b = absolute pressure of steam

$$a = \frac{7 \times 0431}{270} \therefore a = 00112$$

But the co-efficient of discharge is .9, and therefore, the area required should be .0012. This gives a jet diameter of .04 in. The steam nozzle is made from a piece of brass rod, outside diameter $\frac{3}{32}$ inch. (bare). A hole .04 in. diameter is bored through the middle of it, and is tapered out as in sketch. The method of attachment of the nozzle is described later on.

The vane wheel of the turbine consists of a boss, round which a number of suitably shaped vanes are fixed. Outside these vanes is a brass band to keep the steam from escaping through centrifugal force. The dimensions and appearance of the wheel can be seen in Figs. 4 and 5. The boss (Fig. 7) is made of either brass or gun-metal, and can be built up or turned from a casting, the latter course being preferable. Its dimensions are:—Diameter of side plates, $1 \frac{1}{8}$ " diameter of centre, $\frac{3}{8}$ ", thickness of plates, $\frac{3}{32}$ ", distance apart of plates, $\frac{5}{16}$ ".

The centre of the boss extends on one side of the wheel, so that it can be fixed to the shaft by a pin driven right through. In the edges of the plates twenty-four equi-distant cuts are made with a fretsaw, into which the bottom edges of the vanes are sweated. These cuts are at an angle of about 40 degrees, with the side of the plate. The correct shape for the vanes has next to be determined.

Referring to Fig. 6, $A C$ represents the velocity of the steam (about 888 ft. per second) in magnitude and direction, the jet being at 20 degrees to the side of the wheels, and $A D$ equals the linear speed of the wheel, where the jet impinges upon it (about one-third velocity of the steam). Completing the parallelogram, $A B$ equals motion of the steam relative to the wheel. If the vane is then made so that $A B$ is tangent to it at one edge, the steam will glide on without shock, and can then be deflected by the vane. Draw from A , $A E$ at right angles to $A B$, then Q , the point where $A E$ cuts the centre line of the wheel, is the centre from which, with radius $Q A$, the section of the vane is drawn. This radius equals $\frac{3}{32}$ ". The vanes are made from No. 28 B. W. G. brass, $\frac{3}{4}$ " long, and having the curve just found.

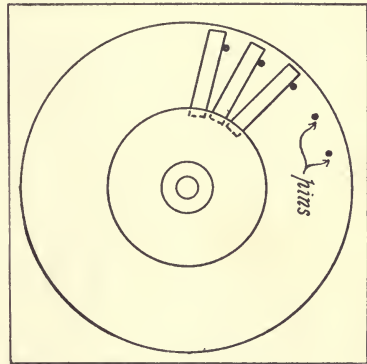

FIG. 9. FIXING BLADES.

A simple device for making all the vanes identically the same can be made as follows:—Clamp two pieces of iron together (Fig. 8), and drill a $\frac{5}{8}$ " hole through them, whose centre is $\frac{1}{8}$ " from the joint, then on separating them, we shall have a mould slightly bigger than the vane. A piece of rod must now be turned up $\frac{9}{16}$ " in diameter, this must be filed away until it is just flush with the top of the mould, when a piece of 28 B. W. G. brass is between them. Twenty-four pieces of brass are then cut $\frac{3}{4}$ " x $1 \frac{1}{16}$ ", these must be carefully annealed and cleansed, they are then placed on the mould, and forced in by hammering the core on top of them. A few strokes with a file will remove the edges of the brass which protrude.

The boss, mounted on a mandrel, is now firmly fixed to a piece of wood with a hole $3\frac{1}{4}$ " in diameter by $\frac{3}{8}$ " deep, turned in it. A circle of ordinary pins must now be driven into the bottom of the hole at equal distances apart. The diameter of this circle should be about $2\frac{3}{4}$ " (Fig. 9). The vanes are now pushed into the saw cuts in the boss, the backs of their outer ends being against the pins. In this way the vanes are held in their places radially.

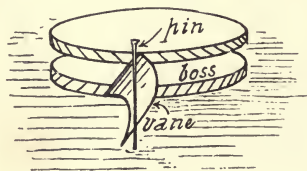

FIG. 9a. SKETCH OF FIXING BLADES.

When all the vanes are in position, a thin mixture of plaster of Paris must be poured into the hole in the wood. When the plaster has thoroughly set, the boss and vanes, firmly imbedded in the plaster, can be taken from the board, the pins having been previously removed. It must then be mounted between centres, and carefully turned down to $2\frac{1}{8}$ " diameter. The outside ring for the wheel is made from a piece of solid drawn brass tubing, 3" diameter and $1\frac{1}{8}$ " wide, this must be thoroughly annealed, and one edge spun over, as in Fig. 4 and 5.

The plaster of Paris must now be carefully chipped away for a depth of about $\frac{1}{4}$ " from the ends of the vanes, and the brass ring slipped into place. A thin layer of solder is then sweated into the inside of this ring, which fixes the outer ends of the vanes firmly to it. The plaster is then chipped away from the other ends of the vanes, which are then sweated to the boss. The other edge of the brass ring must now be carefully spun over. When the remaining plaster of Paris is removed the wheel will be found to be perfectly true and strong.

The shaft is turned from a piece of steel $\frac{1}{16}$ " diameter, and has a disc left at one end in which teeth are cut for the necessary gearing. Its dimensions are:- length, 2"; diameter, $\frac{3}{16}$ "; diameter of boss, $\frac{3}{8}$ "; width of boss, $\frac{1}{4}$ ". The ends of the shaft are pointed and hardened and run in two

hollow centres. The boss of the wheel is bored a good fit on the shaft and is secured by a small pin driven right through it. The case of the turbine consists of two castings, Figs. 10 and 11, fitting into the ends of a piece of $3\frac{1}{2}$ " diameter, solid drawn brass or copper tube, the whole being held together by five bolts, as shown. These castings can be made in either brass or aluminum, preferably the latter.

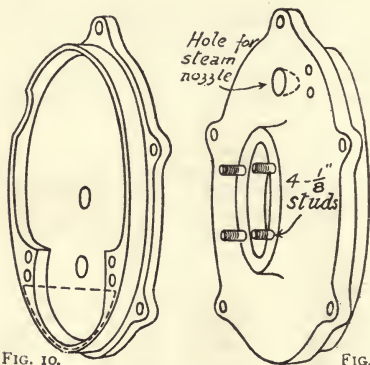

FIG. 10.

FIG.

ENDS OF TURBINE CASING.

Referring to Fig. 1, it will be seen that the left hand bearing for the shaft consists of a steel plate with a counter-sunk boss in the middle, which is attached to the end casting by four $\frac{1}{8}$ " studs, shown in Fig. 11. The boss must be deeply case-hardened for the end of the shaft to run in. The space between the steel plate and the end plate forms an oil chamber, the oil being conveyed to the bearing by a ring as in dynamos.



FIG. 13.
OIL BATH CASING.

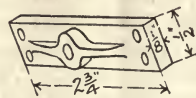

FIG. 12.
BEARING FOR COUNTER.

The right hand bearing is a $\frac{1}{4}$ " countersunk steel stud, screwed through a boss in the end plate, and held in position by a lock nut. This stud is also hardened. The pinion on the shaft gears into a gunmetal wheel $1\frac{1}{8}$ " diameter, mounted on a $\frac{3}{16}$ " shaft. This is supported on

the left by a gunmetal bearing (Fig. 12), screwed to bosses on the end plate.

A thin brass plate is soldered on the inside of the right hand end plate, as shown by dotted lines Fig. 10. This forms an oil bath in which the gear wheel runs, thus carrying oil to the pinion and bearing, and a thin brass cover should be put as in Fig. 13, to keep the oil from splashing all over the case. Oil cups and drain cocks can be fitted as shown to both oil baths. A small hole *B*, Fig. 1 is bored in the end plate to allow any condensed steam to drain from the case, and also in the end plate of the turbine case, and is reamed and filed until the steam nozzle fits in it at an angle of 20 degrees to the plate. The nozzle is held in place by a brass bracket sweated to it, which is fastened by two screws to the end plate. The joint between the nozzle and the end plate should be sweated with soft solder to make it steam tight. The exhaust steam passes through a $\frac{1}{2}$ " diameter tube soldered into the side of the casing.

Before putting the machine together, the vane-wheel should be run between centres and balanced as well as possible by scraping away pieces of solder from the rim of the wheel. When finally adjusting, the vane-wheel bearings should be left the least bit slack, so that the wheel may rotate about its centre of gravity. This is provided for in real De Laval turbines by having a long, flexible shaft, which, however, is impracticable in a model. The above slackness will not effect the gearing, as the steam will force the shaft against the right hand bearing, so that the pinion will remain practically central, any slight eccentricity occurring at the left hand bearing.

Model Engineer, London.

FRUIT AND NUTS AS FOOD.

The United States Department of Agriculture has for several years been conducting a series of experiments to determine the dietary value of different foods.

Nine dietary studies and thirty-one digestion experiments were carried on. In the majority of the dietary studies, and all but one of the digestion experiments, fruit and nuts constituted all,

or almost all, of the diet. The results of the investigation emphasise the fact that both fruit and nuts should be considered as true foods rather than food accessories. The subjects were two women, three children, two elderly men, and two university students. The men all did hard manual labor during a part of the time, the students working to support themselves while pursuing their studies.

The fare given in these experiments was in every case one that would appeal to any normal appetite. It embraced honey, tomatoes, apples, bananas, cantaloupe, grapes verdal, cornichon, tokay, muscat, scarlet haws, pears, pomegranates, persimmons, oranges, strawberries, watermelons, figs, almonds, and peanut butter. The only animal foods allowed were cottage cheese and eggs; and these in limited quantities. The cost of such a diet varied from 15 to 18 cents a day. Comparative experiments were carried along in which animal foods were employed under the usual conditions of living, and in these the daily cost ran from 26 to 30 cents. It was found that the food eaten supplied about 60 per cent. of the protein usually secured by the average meat diet, while health and strength continued the same, if not improved, and in two or three cases there was a slight gain in flesh and weight.

One of the chief objects of the series of experiments was to furnish data as to the value of nuts as food. Fruits contain little protein, and nuts are relied on in the fruitarian plan of eating to balance the ration. Fruits are rich in carbohydrates, and nuts in fat. A pound of peanuts, which costs 7 cents, furnishes 1,000 calories of energy at a cost of 3 $\frac{1}{2}$ cents, and protein at a cost of 36 cents per pound. A porterhouse steak costs for the same result respectively 22 $\frac{1}{2}$ cents and \$1.31, when the steak can be bought for 25 cents per pound.

The average price per pound of the protein of nuts ranges higher than the corresponding average of meats; but the cost per pound of peanut protein is lower than for meats, fish, eggs, milk, dairy produce, and prepared cereals. The only foods which furnish protein at a less cost than peanuts are flour and dried beans. According to Prof. Jaffa's experiments, nuts are the cheapest source of energy for the fruitarian, the peanut ranging far ahead of any other variety.

AMATEUR WORK

77 HILBY ST., BOSTON

DRAPER PUBLISHING CO., PUBLISHERS.

A Monthly Magazine of the Useful Arts and Sciences. Published on the first of each month for the benefit and instruction of the amateur worker.

Subscription Rates for the United States, Canada and Mexico \$1.00 per year. Single copies of any number in current volume, 10 cents.

TO ADVERTISERS.

New advertisements, or changes, intended for a particular issue, should reach the office on or before the 15th of the previous month.

Entered at the Post-office, Boston, as second-class mail matter
Jan. 14, 1902.

JANUARY, 1904.

The turning lathe mentioned in our advertising columns is a tool which the readers of this magazine will undoubtedly welcome with great enthusiasm. It is in no sense a toy, but a practical lathe, upon which good work may be done. Much time has been spent in its design and manufacture, for the sole purpose of securing a lathe satisfactory to the user, and what is of quite equal importance, at moderate cost. There is hardly one of our readers but can easily secure one of these lathes, by devoting a little time to obtaining subscriptions. A large number are being made as we know the demand will be large, and many will want them. Begin work at once and get the subscription of your friends before others have done so.

The first prize in our special premium offer, was awarded to Mr. F. L. Bain, of Cambridge, Mass., who receives the screw-cutting lathe. The winners of the others prizes will be announced in the next issue, several being so close in numbers that the result cannot be determined at the time our forms close. The ease with which some of our readers obtain valuable and useful tools, is ample evidence that others can do the same if they but decide to do it. Try it.

A number of letters have been received from readers relative to binding the numbers of volume II, with a binding uniform with that of the first volume. This matter is now receiving attention, and arrangements being perfected for binding, or supplying covers to enable the binding to be done at a local bindery. Particulars will be given in the next issue.

We are promised delivery on the reprint of volume I, and also the drafting scales at an early date, and same will be immediately sent those who have ordered them.

HANDY RECEIPTS.

BLACK INK.

The chemicals required to make one gallon of best black ink are:—

Nigrosine, "P." 1 ½ oz.

Methilyne Blue, 3° ¼ oz.

To one quart of water, either hot or cold, add the Nigrosine; stir well. To a small quantity of water, add the Methilyne Blue; stir well. Add both solutions together, mixing thoroughly; add enough water to make one gallon. The cost for the above quantity of chemicals is about 25 cents. This formula is in use in many schools throughout the country, and the ink gives excellent satisfaction.

COLORLESS VARNISH.

Colorless varnish for use on fine labels or other prints, as well as for whitewood and other spotless articles, is made as follows:—Dissolve 2 ½ oz. of bleached shellac in one pint of rectified alcohol; to this add 5 oz. of animal boneblack, which should first be heated, and then boil the mixture for about five minutes, filter a small quantity of this through filtering paper and if not fully colorless add more boneblack and boil again. When this has been done, run the mixture through silk and through filtering paper. When cool, it is ready for use. It should be applied with care and uniformity.

REVIVING WEAK DRY BATTERIES.

Old dry batteries, the current of which has become too weak for use, may be revived by punching several holes through the covering of hard pitch on the top, and allowing a solution of sal-ammoniac, or common salt and water, to soak into the cells.

Another way is to punch numerous holes in the sides, place them in glass preserve jars, filling the jars two thirds full of the solution. Considerable additional service may be obtained from cells thus treated, provided they are used where the liquid is not objectionable.

TRANSFORMERS AND CHOKING COILS-

“M. I. E. E.”

FUNDAMENTAL PRINCIPLES. — For purposes of transmission and distribution of electricity for lighting and power purposes on a large scale, high pressure currents are necessary from the economical point of view. As is well known, the adoption of alternating currents has, to a great extent solved the problem of economical distribution; but with alternating current, as with each system of distribution over long distances, arrangements must exist for converting somewhat feeble high tension currents into intense currents at low pressures. Such appliances capable of modifying in an inverse sense the two factors of electrical power, i. e., E. M. F. and current, are included under the general title of transformers. In fact, the claims upon which the superiority and adaptability of alternate currents are based depend upon the possibility of producing high pressures, and of transmitting them with limited loss, and more particularly also upon the facility and economy with which they may be changed from high pressures to low pressures by means of converters.

It is with the intention of placing before our readers a brief outline of the theory, construction, and use of transformers and choking coils that this short series of articles have been prepared.

An alternate current transformer, or simply a transformer, is a simple modification of an induction coil, used for converting small currents at high pressures into large currents at low pressures, and vice versa. It possesses three organs, two separate and distinct copper circuits, and an iron circuit. The iron circuit consists of a well laminated iron core, usually built up of thin, soft sheet-iron strips, so as to form a closed magnetic circuit. This magnetic circuit is interlinked with both of the copper circuits, one of which is supplied with electrical energy, and is known as the primary circuit, while the other becomes the seat of an induced pressure (when the primary current passes,) and is known as the secondary circuit. By varying the relative number of link-

ages, any desired transformation may be effected, and electrical energy in the form of a small current at a high pressure may be transformed into electrical energy in the form of a small current at a low pressure. Such an appliance is termed a *step-down transformer*. When a low pressure current is changed into a high pressure current, the device is termed a *step-up transformer*. It is thus evident that $C_1 E_1$ units of electrical power at a pressure E_1 may be transformed into an equivalent amount of electrical power $C_2 E_2$ at another pressure E_2 . With an ideal transformer

$$C_1 E_1 = C_2 E_2$$

but in practice, however, some losses occur in the process of conversion, and in magnitude $C_2 E_2$ varies from 95 to 97 per cent. of $C_1 E_1$ when working at full load.

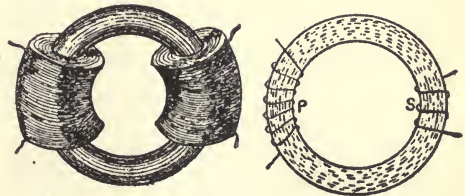

FIG. 1.

FIG. 2.

A transformer, then may be defined as a device which operates so as to produce instantaneously and directly an increase or decrease of current strength at an expense of a change in the voltage. In many respects a transformer is analogous to the hydraulic press, and is an appliance which does for electrical energy what a system of levers and pulleys does for mechanical energy.

In its simplest form a transformer takes the shape of an annular ring of soft iron wire, upon which the primary and secondary coils are wound. For the purpose of explaining the action of a transformer, we shall consider Faraday's first induction coil, which consisted of a solid iron ring, $\frac{1}{2}$ " thick and 6" in external diameter, hav-

ing a primary circuit of wire 72 ft. in length, $\frac{1}{30}$ " in diameter, and a secondary circuit of wire 60 ft. in length, coiled around the iron core at opposite parts as shown in Figs. 1 and 2, in which P. represents the primary circuit, and S the secondary. The primary circuit was formed of three superposed helices. In each case the wire was bare, each wire being insulated from the next by twine, while the layers were insulated from each other and the core by layers of calico. The three coils on the primary could be used separately or conjointly, in series or in parallel. The dotted circles in Fig. 2 represent the lines of magnetic force or magnetic flux which are set up when a current circulates through P. In Faraday's experiments the current through P was made intermittent, with the result that transient induced currents were produced in S. In practice only alternating currents are used in the primary circuit, and alternating currents are produced in the secondary circuit. Thus, if an alternating current, having a frequency of f periods per second, traverses the primary coil P of our primitive transformer (Figs. 1 and 2), it is obvious that an alternating magnetic flux is developed in the iron core, with the result that a periodic magnetic flux pulsates in opposite directions through the circuit S. This threading or linking of S with an alternating magnetic flux fills and empties the secondary coils at rapid rate, and, according to the laws of electro-magnetic induction, it is clear that an alternating electromotive force, having the same frequency as the primary current supplied, will be induced in S. Furthermore, if the ends of the secondary coil be connected by lamps or wire, an alternating current will traverse this circuit. We thus see that part of the electrical power expended in the primary circuit is recovered in the secondary circuit, and the sources of loss, as we shall presently show, account for the remaining 4 or 5 per cent. of the power expended. As is well known, the inductive action upon which transformers depend exists only while the primary current varies.

At this point it is important to notice that the function of the iron is twofold. (1) It augments the number of lines of force due to the primary current; and (2) it plays the part of a carrier, or forms a suitable medium for the magnetic flux. Consequently, the same result would be produced

without the iron core, by placing the secondary coil relatively to P, so that the flux due to the primary current in P, assuming it to be of the same magnitude as when the iron is present, threads itself, and links itself with the coils forming the secondary circuit. It is therefore evident that the E. M. F. is induced in the secondary depends upon, and is a measure of, the *mutual induction* between the two circuits P and S. In many respects the production of this secondary E. M. F. may be compared to the production of the E. M. F. in the armature of dynamo, although there is no revolving mechanism or moving parts in a transformer. It is also an advantage that transformers need no commutator. The action of the primary circuit is identical with the field coil of a dynamo, whilst the secondary circuit corresponds to the armature coils. In each case relative movement between a magnetic flux and a coil of wire yields induced E. M. F.'s, which in both instances are proportional to the number of turns of wire forming the secondary circuit. In the case of the transformer the nature of the current in the primary circuit P produces the variation in the number of leakages of the lines of force with the secondary circuit S.

English Mechanic.

An Italian has invented a saturation hygrometer which may be used for determining the tension of aqueous vapor in the air in small spaces, such as instrument cases; a portion of the air to be examined is withdrawn and saturated with aqueous vapor, and the increase in pressure thus caused is noted. Knowing the saturation vapor pressure, it is possible to deduce the aqueous vapor of the experimental air. The apparatus consists of a bronze receiver fitted with a thermometer; into the receiver passes a glass tube drawn out at the lower end, and connected at the upper end with a syringe which serves to force in drops of water. The receiver may be put in communication with the exterior air, and carries at the side a graduated tube of 3.2mm. diameter, containing a column of petroleum 2.5cm. long.

The turning lathe is the best premium ever offered in this country.

THE GRINDSTONE AND ITS USE.

OLCOTT HASKELL.

Sloyd Instructor, Hitchcock Military Academy, San Rafael, California.

The dirt and inaccuracy usually accompanying work at the grindstone are certainly not attractive features, and it is the object of the writer to suggest ways in which these objections may be lessened and the work made more agreeable. Assuming that we have an ordinary foot-power grindstone some 18" in diameter x 2 1/2" thick, mounted after the customary manner in an open wooden frame, it should be clamped securely to the axle with the bearings true and in good order that all parts may run easily.

solder to the jagged edges of this hole and work the punch through the hole until the edges are quite smooth and even. A piece of wood pointed to fit loosely in this hole makes an excellent drip faucet. Prepare a holder for this can by fitting a 3-4" dowel into a hole bored in the frame at the back of the grindstone, slitting the top of the dowel with a saw to receive the ends of a wide band of heavy tin, which band should be bent loosely around the can and nailed securely in the saw slit. A piece of wood 1-2" x 4" x 7" nailed to the front of the stone prevents the can from falling through the holder, and also arrests drops from the stone. By revolving the can the water may be made to fall on whatever part of the stone it is most needed.

To catch the waste water secure a sheet of rather thin zinc 13" wide, x 36" long and bend up the

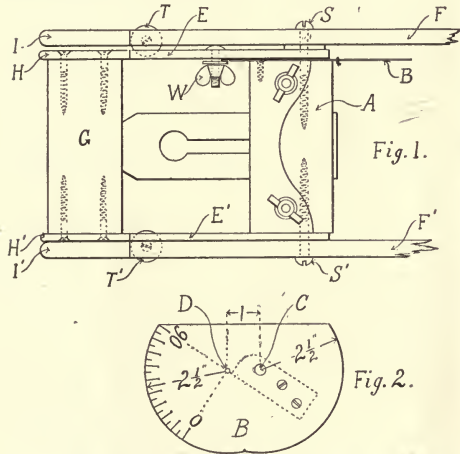

An important point to consider is the water supply, since it is necessary during grinding to have the stone thoroughly wet to keep the tool from heating, and also to wash away the dust and waste particles of steel, thus keeping the surface of the stone in good cutting condition. If the lower portion of the stone is run through water (as is frequently done) it will pick up more water than is necessary, the excess splashing and dripping, also when the stone is left standing the part in contact with the water is softened, causing the stone to wear more on that side and become eccentric. Hence the most satisfactory arrangement is to have a small drip-can above the stone, and a trough or pan beneath to catch the waste water.

For a drip-can secure an open tin about 4" in diameter x 4" deep and near one edge drive a centre punch from the inside through the bottom. Melt a drop of



sides to form a square trough 36" long, x 6" wide x 3 1-2" deep. Then at one third of the length from either end crimp and fold in the edges, so as to cause the end portions of the trough to stand up at an angle of about 60° with the base. This folding must be done carefully and edges of the folds should be left somewhat rounded, as hammering the zinc flat might

break it, causing leaks that would have to be stopped with solder or melted paraffin. Bore or punch a $\frac{1}{2}$ " hole in the centre of the trough, and by working around carefully from the inside with tapering instruments, such as the rounding handles of a small pair of pliers, burnish and spread the edges until the hole is about $\frac{3}{4}$ " in diameter. This action should form a smooth rounded lip to the hole so that it may be securely plugged with a rubber stopper. The grindstone must now be removed from its frame and the completed trough nailed in. Such a trough is easily made, and having no joints it cannot leak. In practice it will seldom need emptying, as the water usually evaporates between the periods of grinding. A shallow hopper-shaped frame may be secured around the sides of the stone to catch stray drops, and lead them where they shall fall into the zinc trough.



The grindstone will now be in a much more usable condition than at first, but still our best efforts at grinding will be merely guess work so far as accurate angles are concerned. The following grinding frame is designed to enable us to grind accurately to any desired angle. The accompanying photographs give excellent general views of this frame together with the other fittings, and Fig. 1 gives a top view of the upper end of the frame, while Fig. 2 shows a protractor for measuring the angles.

The grinding frame is formed of the two maple strips $F-F'$ $1-2'' \times 1-1-2'' \times \frac{3}{8}''$ which have their lower ends secured to a block of oak or maple $1-1-2'' \times 6'' \times 13''$, and terminate in handles which are joined by having the inner tool frame $A-E-E'$ pivoted between them on

the screws $S-S'$. The entire frame is hinged to the rear of the grindstone support, and is weighted at its lower end, so that when not in use it swings into a vertical position. A firm T hinge should be used and it should be fastened by a single screw to the under side of the block on the grinding frame so that this frame may have motion from right to left as well as up and down.

Referring to Fig. 1, A , is a piece of maple $1'' \times 2 \frac{1}{2}'' \times 5 \frac{1}{4}''$ beveled off along its front edge so that the edge of the tool, which should extend $3-16''$ but beyond the block, may be readily seen. Tools are secured to the under side of this block by a strip of $5-16'' \times 1 \frac{1}{4}'' \times 5''$ maple clamped by the two $1-4'' \times 2-1-4''$ carriage bolts fitted with thumb nuts as shown. To one end of A is firmly screwed the protractor B , shown more clearly in Fig. 2, where the dotted lines indicate the position of the end of A when secured in place. This protractor may be made of heavy sheet brass or of galvanized iron and should have its outline formed by arcs of circles described from the centres C and D respectively as shown. C is a $1-4''$ hole drilled to receive the round headed screw S . D is a small hole just large enough to admit one end of a short length of flexible twine which is secured in the hole by a knot at the back. D is in line with the prolonged edge of the tool to be ground and so mark the centre of the circle on which the degrees may be marked. G is a block of the same length as A and having the two side pieces $E-E'$ of $1-4'' \times 1-1-2'' \times 9''$ maple securely fastened to it by several long screws.

It will be seen when the screws $S-S'$ are passed loosely through the arms $F-E$ and $F'-E'$ respectively and screwed into the block A , that this block, carrying the tool and the protractor, will turn freely within the frame $E-E'-G$, and that this inner frame is also free to turn between the arms $F-F'$ until its motion is arrested by the stops $T-T'$ which are formed of the two large iron washers screwed to the under sides of $F-F'$. A short carriage bolt W , is fitted with a washer and thumb nut, serving to clamp the protractor together (with the block A , carrying the tool) securely at any desired angle with reference to the inner frame.

The several parts being put together as described, the method of grinding a tool is as follows: Clamp the tool in place with its edge extending $3-16''$ beyond the edge of the block A ; turn the inner frame so that its handles $H-H'$ come down in place against the stops $T-T'$ of the outer frame; then rest the tool upon the face of the stone and stretch the string from D down to touch the middle of the grindstone axle; move the protractor until the string falls across the desired number of degree divisions, and clamp securely in this position by means of the thumb nut W . The frame may now be pressed firmly down and the tool ground. To ascertain whether the grinding has progressed sufficiently, it is only necessary to slightly lift the grinding frame and revolve the inner frame until the newly ground face of the tool comes upper-

most. This rest not only grinds accurately to any given angle, but enables one to give a slightly hollow face to the tail, thus greatly facilitating the whetting.

Should the grindstone become uneven, its face may be trued up by holding the end of a short length of iron pipe against the stand, resting the pipe firmly

against its framework and rolling it from side to side across the dry face of the stone. When the stone becomes too smooth to cut rapidly, as it frequently may in grinding hard steel, holding the side of the pipe firmly upon the stone during a few turns will clear the surface and put it again in good condition.

HOW TO BUILD A SAILBOAT.

CARL H. CLARK.

I. Lines and Laying Out.

The type chosen as being the easiest for the amateur to build is that known as the "square sider," as the lines are to a large extent straight with few sharp turns, thus making the easiest possible boat to build. As will be seen from the illustration, the lines of the top sides and of the bottom are all straight, meeting at a more or less sharp corner. While at first sight it might seem as though this corner were a disfigure-

The boat as laid out will be found very easy to build, and at the same time very strong, and a good heavy weather boat. While this type is, of course, not quite so fast as an extreme round bottomed boat with long overhangs, it is nevertheless a good sailer and a much better sea boat than she would be with long ends as the latter are apt to pound and throw spray aft.

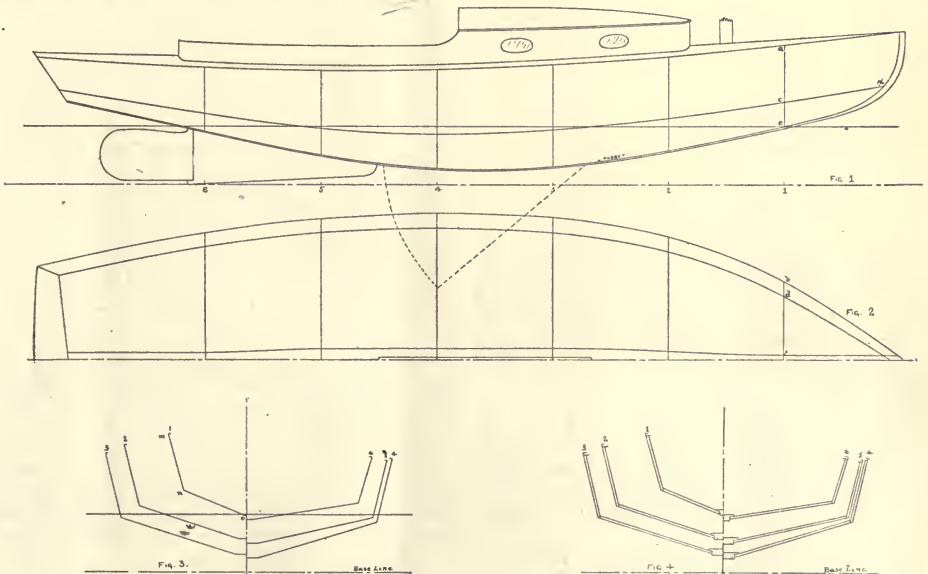

ment, it proves not to be so in the actual boat, the lines being a close approximation to those of a round bottomed boat similar to the popular "knock about," but as this boat is intended for rough all around weather it was thought advisable to shorten the overhangs to make her easier in a sea way.

The boat as laid out is about 16 feet on the waterline and is not so large but that she can be easily built, and yet large enough for two people to sleep aboard comfortable, a small cabin trunk being provided for that purpose.

In starting to build, the first thing is to choose a

suitable place. The best place is one where there is plenty of light and with strong beams overhead. The latter is a very important consideration, as the beams are used to brace against, and it would be almost impossible to do any boat building without them. A wooden floor is also desirable to which braces and blocking may be nailed.

In order to make patterns, or moulds as they are termed, of the several parts, it will be necessary to reproduce a part of the lines full size on a smooth floor. If this is not available a temporary one of boards may be laid, one about four feet wide, and the length of the boat being needed. If desired, in place of this floor a piece of drawing paper may be laid down on any available floor, and removed after the work is done. This will be a good way to preserve the lines for reference.

LAYING DOWN TABLE

POSITIONS	1	2	3	4	5	6
1. Height of sheer above base line	3' 7"	3' 3 1/2"	3' 1"	2' 11 1/2"	2' 11"	5' 0"
2. Breadth ,, ,, ,, ,, ,,	2' 10 1/8"	3' 1 7/8"	3' 7 1/4"	3' 9 1/4"	3' 7 1/2"	3' 3'
3. Height ,, knuckle above base line	2' 1 1/4"	1' 8 3/4"	1' 4 3/4"	1' 3 1/2"	1' 5 1/4"	1' 9 1/2"
4. Breadth ,, ,, ,, ,, ,,	1' 7 1/4"	2' 9 3/8"	3' 3 1/2"	3' 4 1/2"	3' 3 1/4"	2' 10 3/4"
5. Height ,, rabbet ,, ,, ,,	1' 6"	10 1/2"	5 3/4"	5"	9"	1' 4 3/8"
6. Breadth ,, ,, ,, ,, ,,	1 1/2"	2 3/8"	3 3/4"	3 1/2"	3 3/4"	2 1/2"
Height of bow at rabbet	3' 11 1-4"					
Distance forward of section 1 of rabbet at bow,	2' 11 1-2"					
Height of sheer at stern	3' 3"					
Breadth ,, ,, ,, ,,	2' 4 3-4"					
Height of knuckle at stern	2' 5"					
Breadth ,, ,, ,, ,,	2' 2"					
Height of rabbet ,, ,,	3' 1 3-4"					
Breadth ,, ,, ,, ,,	2 1-2"					
The point <i>x</i> above base line is	2' 6 1-4"					
,, ,, ,, forward of section 1, is	2' 6 3-4"					

In order to make a portion of the keel, stem and cross section moulds, it will be desirable, if possible, to lay out the outlines of the sheer plan and the cross sections. The measurements will be found on the drawing. The base line is struck in with a chalk line and the cross sections laid off three feet apart, being sure to make them square with the L. W. L. (Load water line.) The distances are then laid off above or below this line, and fair lines run through them. It may be found that a line exactly through the points would not be fair on account of the unavoidable error in scaling from a small drawing, and laying off again, with a little judgment, a fair line can be struck.

For running curved lines a batten or staff about 1 1-4 in. square and 20 feet long is used, held in place by nails or awls driven alongside of it. When satisfactory lines are secured, they are scratched into the floor with a sharp awl. In the sheer plan the only lines necessary are the deck line, the rabbet, and the top and bottom of the keel. The measurements given are to the rabbet, but the bottom of the keel is 1-2 in.

below the rabbet, and the keel is 2 in. thick, so that these lines are easily put in. The cross sections are the only other lines needed, and are laid off as in the drawing; the height of the upper corner being made to agree with the sheer already laid out.

The accompanying table gives the required data for laying out this mould and also those for the moulds for the cross sections and keel. Line 1 gives the height of the top of each section above the base line, which is 18" below the waterline. Line 2 gives the breadths of the corresponding points from the centreline. Line 3 gives the height of the before mentioned knuckle, or line of jointure of the two straight lines composing each section and line 4 shows the half breadths of the same points. Line 4 and 5 gives the height and half breadths of the rabbet, or the line where the outer surface of the plank joins the keel.

The sheer plan and the half breadth should be laid out as shown in Fig. 1 and 2, these are laid out from the table above, and the outlines made fair. The only lines required are the sheer, the knuckle line and the rabbet line, the dimensions of the overhangs are shown additionally in Fig. 1. The cross sections, shown in Fig. 3 are obtained by coupling the other two plans, for instance, on section 1 the height and half breadth of the sheer point are shown at *a* and *b* which height and half breadth are used to locate the point in Fig. 3. The points *c* and *d* show the height and half breadth of the knuckle on the same frame, which dimensions are used to locate the point *n* in Fig. 3. In the same way the point *o* is located from *e* and *f*. The three points *m*, *n*, *o* thus gotten are connected by straight line to complete the outline of the frame.

The frames are all to be drawn in the same manner, and used later as patterns to which to fit the moulds or forms upon which the boat is built. The line of the keel is drawn in 1-2 inch below the rabbet, and the line of the top of the keel so drawn as to make the keel 2" thick. The lines as laid out so far are drawn to the outside of the plank, whereas the moulds which are to be made and used to set up the boat must be made to fit the inside of the plank, as the latter are to be bent around them. It will thus be necessary to draw inside of each cross section or mould already drawn, another one smaller by the thickness of the plank and deck as shown in Fig. 4. This thickness is 3-4" and the new section is formed by drawing the new lines inside the old ones at a distance of 3-4". It is also desirable to lay in the keel for convenience in trimming the moulds to fit over the keel when set up.

The bottom of the keel is 1-2" below the rabbet and the keel is 2" thick. The top side of the keel projects over on to the plank 1-2" to form a back rabbet and give fastening for the plank. The widths across the top also give the widths of the keel at each point, which makes it easy to lay off the keel outline.

The laying off on the floor may seem rather tedious but it is the easiest in the end, and also makes a pattern upon which the several parts may be laid to test their fairness. It will be well to take considerable pains with this part of the work, in order that the boat may come fair when set up, and thus save all paring and filling out.

The sternboard, as shown in Fig. 5, is also laid out. Following the lines laid on the floor, a wooden pattern is to be made out of stock about 1-2" thick to fit the line of the bottom of the keel. It should run the whole length of the keel and stem, and at the forward end should follow the forward side of stem, and at the stern a piece should be fastened on showing the angle of the sternboard. The positions of the cross sections are marked on this mould and also the posi-

tion of the centreboard slot. It must be so braced that it can be carried about without springing out of shape. This mould is very important as it fixes the shape of the boat and must be accurately laid out.

So much depends upon the shape of the keel, that this must be correct. The best way to assume this will be to build a solid foundation. A 2" spruce plank about 10" wide is set up on edges about 15" from the floor, and strongly braced in position. Then using the mould just made as a pattern, the plank is cut to fit it and the ends built up with other pieces of plank and the whole trimmed out until the mould rests evenly on it from stern to the round of the bow. It is then braced sidewise and endwise to be able to stand considerable pressure. This gives a solid foundation to bend the keel into and prevents its changing shape during building.

The same shape could of course, be built up of blocks fastened one on top of another, and securely braced, the tops being beveled off to fit the moulds this is, however not as good as a solid foundation and the former method as much to be preferred.

HAND SAWS, THEIR CONSTRUCTION AND USE.

EXTRACTS FROM "HANDBOOK FOR LUMBERMEN," HENRY DISSTON & SONS.

Fig. 13 is a representation of some of the saws we have seen; there are entirely too many such now in use, and we have no doubt their owners are shortening their lives in the use of them as well as those of the saws. To owners of such saws we say, take them to the factory and have them retooled, or buy a new saw and take a fresh start, and steer clear of this style of filing.

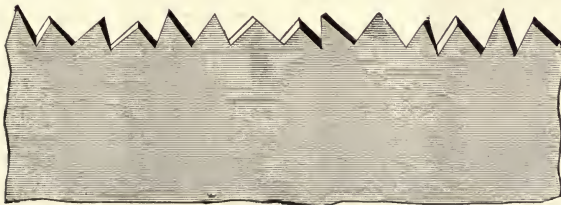

FIG. 13.

but the only support they have for their theory is that they do away with the feather edge that the filing from the heel of saw puts on the cutting face of tooth. The feather edge is no objection, as the main part of it is removed when the teeth are side-dressed after filing, as we direct in our summary of saw filing on Against the correctness of filing from point to handle may be cited the following objections:—

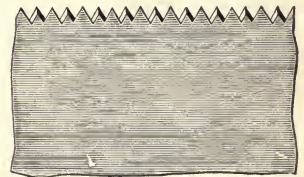

FIG. 14.

As we said in the preceding pages, and as will be seen by Figs. 10, 11 and 12, the filing should be done from the heel of saw toward the point. Many practical saw filers contend this is wrong, that the filing should be done from point of saw toward the handle,

Where a different angle of back is required (it being remembered that angle of face should be the same in nearly all cross-cut hand saws, and that angle of back governs angle of point), it will be found very difficult to obtain it without changing angle of face of tooth,

and as the cutting duty is on the long side of face, any change is of course of great influence. Again, (though we think the above argument sufficient) to file from point of saw, it is necessary to file with the teeth bent towards the operator; this will cause the saw to vibrate or chatter, which not only renders good, clean, even filing impossible, but breaks the teeth off the file.



FIG. 15.

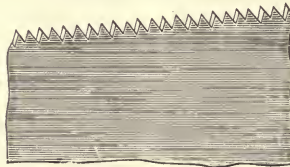

FIG. 16.

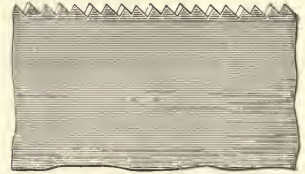

FIG. 17.

In the preceding illustrations, we have only given the coarser saws that are in most general use, but the same principle of filing should be applied to the finer toothed saws regarding angles and pitch suitable for woods of different degrees of hardness, the only actual difference being that one saw has finer points, and they being finer, require a little more care and delicate touch in setting and filing.

Fig. 13 is a section of an eleven-point saw suitable for the finer kinds of work on dry, soft woods, such as cutting mitres, dove-tailing, pattern work etc.

Fig. 15 shows a section of a saw with same number of points of Fig. 14, but filed same as Fig. 12. This saw is for finer work, same as Fig. 14 only on the medium hard woods. Fig. 16 is a still finer saw for fine work on the very hardest woods having same dress as Fig. 14.

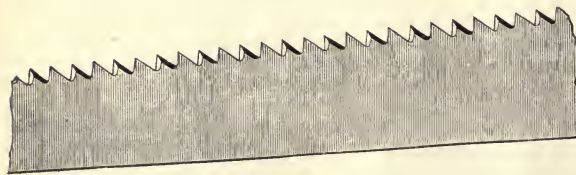

FIG. 18.

Fig. 17 is the finest tooth saw of its kind that is made for wood. All the above mentioned saws in Figs. 14, 15, 16 and 17. are made especially hard and will not admit of setting, but being made thinner at the back, when properly filed, will cut clean and sweet. Teeth such as shown in Fig. 17 are used principally on back saws and smooth cutting hand-saws. To maintain the original shape of these teeth use a cant safe back file.

Fig. 18 is a section of a pruning saw which differs from a cross-cut hand saw in being thicker, having a little more pitch to the teeth and being ground thin-

ner on the back in proportion to its width. These of course, are made for cross-cutting only, as there is not as great a variety in the work, nor as much difference in the woods to be sawed as to degrees of hardness, being used only as a pruning saw on fruit and shade trees, which are always practically green and comparatively soft.

The "nib" near the end of a hand saw has no

practical use whatever, it merely serves to break the straight line of the back of blade and is an ornamentation only.

COMPASS SAWS.

These saws are for miscellaneous sawing. The best form of tooth for this purpose is the same as Fig. 18, excepting that it has a trifle less bevel. As the nature of the work partakes about as much of cross-cutting as of ripping, and as a cross-cut saw will rip better than a rip will cross-cut, it is apparent the shape of tooth should be between the two. These saws are all ground, filed and set in the same manner. Scroll and web saws are ground, filed and set in the same manner, and should have pitch according to the work to be done. If more ripping than cross-cutting is done



FIG. 19.

as in large felloes, more pitch is given than in compass saws and *vice versa*, though these saws are almost universally run with a rip-saw tooth and have very little variation in the pitch.

HACK SAWS..

These saws are for cutting metal, such as brass, iron or untempered steel, and should have a little finer tooth than the average butcher saw. They are so hard that none but the best superfine files will sharpen them. Like the butcher saws, filing must be done straight through and no bevel.

SETTING SAWS.

This is an important part of the work of keeping in order and should always be done *after* the teeth are *jointed* and before filing. In all cases the set should be perfectly uniform, as the good working of the saw depends as much on this as on the filing. Whether the saw is fine or coarse, the depth of set should not go, at the most, lower than half the length of the

tooth, as it is certain to spring the body of saw if not break the tooth out. Soft, wet woods require more set as well as coarser teeth than dry, hard woods. For fine work on dry woods, either hard or soft, it is best to have a saw that is ground so thin on the back that it requires no set; such saws are made hard and will not stand setting, and an attempt to do so would surely break the teeth out.

GAS ENGINE SPARK COILS.

ALBERT GRAHAM.

II. Coil for "Jump Spark" Ignition.

A "fat" spark is desired to insure regular ignition, and to avoid "misfiring," a trouble frequently met in the operation of gas engines, but which may be almost entirely avoided if care be taken to see that all parts are in good working order, and correctly adjusted. For engines of comparatively small size, the length of spark which can be produced from a coil is not so important as that the spark shall be full or strong enough to affect ignition with regularity. The coil here described, if carefully made, will be found adequate for this purpose. It is about the size rated as a half-inch spark coil. A vibrator is shown, but can be dispensed with under certain conditions.

The dimensions of the several parts are as follows:

Length of core	5 inches
Diameter of core	5-8 "
Gauge of core wire	20 Gauge
Primary coil, two layers	No. 16, C. C. M. W.
Secondary coil, 1 pound	" 34, C. C. M. W.
Condenser, 40 sheets foil,	4 x 5 inches
Condenser, 60 " , paper,	6 x 8 inches

To make the core, cut into 5" lengths, enough soft iron wire, 20 gauge to make a round bundle 3/8" diameter; about 150 pieces being the required number. It is quite necessary that they be very soft. If doubt exists on this point, wrap some binding wire around the bundle and put in the fire, allowing it to remain over night, taking it out in the morning when a new fire is made. Then clean and rebind and after dipping the ends in solder so as to secure a solid end, remove the binding wire, file the ends smooth, and soak in paraffin. This may be kept fluid if a hot water bath is used. Do not heat on the fire in a single vessel, as it may possibly ignite when so heated.

Procure or make a round paper tube, 5-8" inside diameter 5" long and about 1-16" thick, mailing tube of the right size will answer. Coat well with spirits shellac and then insert the wire core; the ends of the latter should project about 1-16" on the hammer end. The primary coil is then wound in two layers upon

the inside of this tube, No. 16 single cotton covered magnet wire being used. Leave about 6" of wire free at the ends for connections. This coil is 4" long. Coat each layer with spirit shellac, which makes a good insulation. The outside diameter of this coil will be about 1/2". A piece of thick hard rubber or fibre tubing 1 1/2" inside diameter is then placed over the primary coil. To the ends of this tubing fit square ends A of hard rubber or wood 1/2" thick. If wood is used give it several coatings of spirit shellac, paying particular attention to the joint between the ends and the tube. The ends should be 4" apart, inside

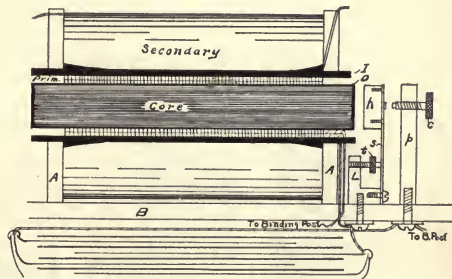

measurements. From the top side of one end drill a 1-16" hole which will just open at the lower inner side close to the tube. The end of the wire for the secondary coil is put through this hole from the inside, with a short length projecting for connections. Before doing this, however, increase the thickness of the tube at the ends about 1-8" with several layers of thin bond paper, coating each and binding same with shellac. Be sure to keep the opening clear to the hole in the end for the secondary wire.

The secondary coil can then be wound, after testing the wire with a galvanometer to ascertain that there are no breaks. In winding also, constantly examine the wire, to locate poorly insulated, bent or broken

places which would cause trouble and perhaps spoil the action of the coil. As each layer of the secondary is wound, baste well with paraffin applied with a small, flat brush. Before winding the final layer, put on a single thickness of thin, smooth bond writing paper, and then wind the final layer, the paper giving a smooth, even finish to it. The end of the wire is put through a hole drilled in the other end piece, leaving end for connections.

The vibrator, if one is used, is made as follows:—The hammer head *h* is cut with a hack saw from a piece of round annealed bar iron, and is $\frac{3}{8}$ " diameter and $\frac{1}{4}$ " thick. It is finished smooth on the faces with a file, then fastened with two minute screws to the piece of spring brass *s*, which is $1\frac{1}{4}$ " long, $\frac{1}{4}$ " wide and about No. 26 guage. The other end of the spring is fastened by a machine screw to the foot *L*, cut out of a piece of bar brass. This is 1-2" on the base, $\frac{3}{4}$ " high and $\frac{1}{2}$ " wide. A hole is tapped in the base for the screw holding it to the stand, and also for the tension regulator *t*. This regulator is made by drilling the end of a knurled head, machine screw and forcing in a piece of brass wire. The post *p* is a piece of round, brass rod $\frac{1}{4}$ " diameter and $1\frac{1}{2}$ " long. The lower end is tapped for a screw to hold it to the base, a washer being placed under the head of the screw, and at the top and directly in line with the centre of the hammer for the contact screw *C*. This screw should have a knurled head, and the point tipped with a bit of platinum. The point of contact at the back of the hammer should also have a piece of platinum soldered to it. To solder on the platinum heat the part, place a drop of melted solder and allow it to cool enough to see if the solder holds, then warm with blow pipe until fluid and place the piece of platinum in it and cool. The vibrator should be so located and adjusted that the hammer will, when the coil is in operation, vibrate so rapidly as to make a distinct buzzing.

The condenser is made as follows:—Forty sheets

of thin tin foil are cut 4" x 5". Sixty sheets of thin wax paper are cut 6" x 7". Lay a piece of smooth writing paper on a smooth surface, lay on a piece of the wax paper, then a piece of the foil, with the end overlapping the paper $\frac{1}{4}$ ", then another piece of wax paper. Another piece of the foil is then laid on but this time overlapping on the left end. Follow with alternate layers of paper and foil, the ends of the latter projecting alternately on either end, until all the sheets of foil have been used. Examine the paper carefully, rejecting any sheets with holes. If suitable wax paper cannot be purchased, soak thin bond writing paper in paraffin, and smooth with a warm flat iron, interposing a sheet of ordinary paper between the iron and wax paper. Every few layers press with a flat-iron.

The overlapping ends of foil are soldered together with soft solder as follows:—First bring all the ends together with a slight turn, which may be done by pressing them over a small round rod about $\frac{1}{4}$ " diameter. Trim all the ends even and fasten together at two or three places by punching a hole and binding with a fine copper wire. Make a V shaped trough from a strip of sheet iron, closing the ends with putty. Fill this trough to the depth of about 3-16" with the molten solder, and put one end of the condenser into it and let harden. It must not be too hot otherwise the foil will melt away from the sheets. If well done, all the sheets will be connected with the solder, to which attach the connecting wires with a drop of solder.

As previously mentioned, a vibrator is not used by some gas engine builders, one fat spark being preferred, if the timing can be accurately adjusted, to the less strong, but more numerous sparks caused by the vibrator. The writer has had no personal experience with a coil without a vibrator, so cannot say how satisfactory a working can thus be obtained. Perhaps some of the readers of this magazine can give information on this point.

PRINTING FOR BEGINNERS.

FREDERICK A. DRAPER.

III. Cases, Stands and Other Furnishings.

To separate words and characters, spaces of varying width are used, the thinner ones being termed spaces and the thicker, quods, shortened from quadrates. In shape they resemble the type, but are shorter and thus make no impression on the paper. The spaces are fractional parts of the em quod; hair line, eight to the em; thin, five to em; middle, four to em; thick, three to em. In addition is the en quod, one half the thickness of the em quod.

Spaces and quods are not included in fonts of type, but must be ordered separately, one pound to the font being the minimum quantity for satisfactory work, and double this amount or more will often be required. They can be purchased in fonts containing an assortment of each size of spaces and quods, or any one size may also be ordered in quantity as desired.

Additional very thin spaces cast in copper, one-half and one point in thickness, are much used in justifying

lines in advertisements, and also for separating letters in a line to make it more extended. The thick space is the one most commonly used for separating words, and nearly one-third the amount purchased should be of this size. The em quad is used to separate each sentence in a paragraph, also to indent the beginning of a paragraph, and the wider quads to fill out a line not fully occupied by type.

Type, for convenience in handling, is laid in cases which are manufactured in numerous sizes and arrangements of pockets. Body type, or type of which any considerable quantity is required, is laid in a pair of "News" cases; the "Upper case" containing the large and small capital letters, brackets, dashes and less used characters; and "Lower case" containing

ing is effected when these are obtained, the usual price for second hand cases in good condition being one-third the list price of new cases. A stand can be made for storing cases, one working stand being pur-



CAP OR UPPER CASE.



CALIFORNIA JOB CASE.

chased, and here again the second hand dealer can be visited to good advantage. A lead and slug case is also necessary, and is a labor saving devise well worth the small sum required for its purchase. A special

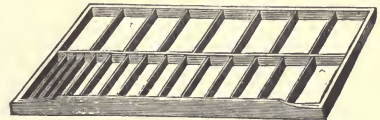

LEAD AND SLUG CASE.



LOWER CASE.

case for fractions is desirable if work is done which requires their use to any considerable extent. Figures for time table and similar tabular work are usually laid in a special case. Type is composed or "set" in

the small letters, figures, spaces and quads, punctuation marks, and a few characters. The places occupied by these cases on a "Stand" is indicated by their names, the upper case being at the back, and the lower case in front.

Unless room is greatly restricted or the type outfit an extremely limited one, type should be laid in full size cases. "Two third" cases are convenient for single fonts, and are suitable for amateurs' use, but preference should be given to the larger cases. For job fonts containing no small capital letters, the arrangement known as a "California Job" case is the one most generally used. Old cases can be purchased of dealers in second hand materials, but California job cases are so much in demand that new cases will probably have to be purchased. Two third cases can often be found second hand, and a considerable sav-

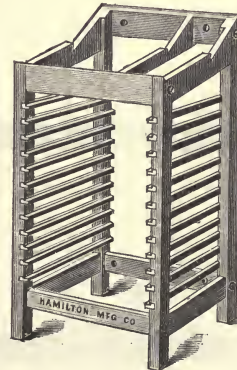

SINGLE STAND.

a composing stick, an assortment of sizes being desirable according to the amount and variety of the work. The kind known as a "Screw" stick is the best for regular work in which the measure is not changed. The "Yankee" stick is used for job work and advertisements, as alterations are quickly made.

Reglets are strips of oiled, hard wood about 5-8 of an inch in height, and used for separating lines or sections of type matter, and for filling out the space in the chase preparatory to "locking up" for the

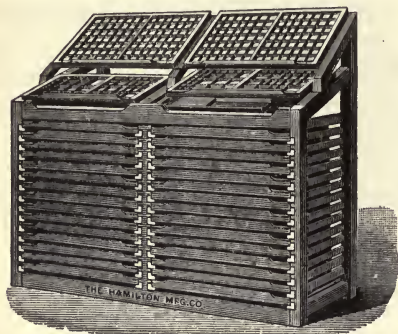

DOUBLE STAND.

press. The commonly used widths are 6, 8, 10, 12, 18, 24, 36, 48, 72 and 144 points, each strip being a yard long. Reglets are of more particular value on odd jobs, where the use of leads would mean the cutting of many pieces not generally usable in other work. The wider pieces are also termed "furniture" and cabinets filled with the more commonly used lengths and widths are to be found in most job offices. The sizes most likely to be of use to the small office are the 6, 12, 24, 48 and 144 point widths, the lengths being cut as required.

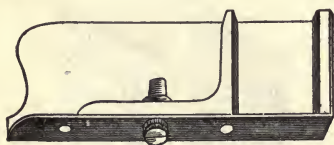

SCREW COMPOSING STICK.



YANKEE TOP STICK.

Leads are strips of metal, similar to type metal, of varying thickness and used to place between lines of type to separate them. The stock thicknesses are 1, 2, 4, 6, 10 and 12 points, those 2 points thick being commonly used for single leaded matter. If a lead

cutter is included in the outfit of an office, it is best to buy leads in the regular lengths of two feet, and cut it up as needed. It is important that the lengths be multiples of pica ems. As steel measures of the various lengths are expensive, a cheap substitute is to purchase at a type foundry one each of the different lengths of 12 point leads or slugs. As these are machine cut with smooth ends they serve the double purpose of gauges for cutting leads and setting the measure of composing sticks. These gauge slugs should be handled carefully, and used for no other purposes than those just mentioned.

Furniture is also made of metal, and a suitable stock should form a part of every office equipment. It greatly facilitates the adjustment of cuts, and as it has even and square surfaces, enables a firm "lock up" to be secured where the lines are other than of uniform length. A piece of metal furniture is usually placed at the foot of the standing matter on a galley to keep it in place when handling.

The more generally used materials having been described, we can now consider the handling of them. Upon receiving a font of type from the foundry, the first thing is to lay it in the case. The paper covering is removed by unfolding in such a way that the last turn removed will leave the type face up on the galley with the paper underneath. Slightly moisten the type with a wet sponge, which causes it to cling one to another; otherwise the characters at the ends are quite likely to fall over. Then draw the wrapper from under the type, using care not to upset it. In many offices it is customary to take a proof of the font before throwing in, to ascertain if all the characters are included. Also, if the font is to be added to others of the same kind already on hand, examine the nicks and shoulders of the lower case "m" and cap "H" to see if the new font is identical with the old. When ordering type, about which any uncertainty exists as to kind or face, it is customary to send to the foundry as samples the two letters above mentioned.

An inspection of the font having shown it to be correct, it is then placed in the case, the compartments for the several characters, if a job font, being located as shown in the illustration. While at first, the peculiar arrangement may seem confusing. A little experience will show that the main purpose is to save labor by reducing the distance the hand moves in securing the type. It will be noted that the cap V is located between the T and W, the V being underneath the T. In some offices this arrangement of the two letters is reversed, and the writer has a preference for the latter way.

Probably the easiest way to "learn the case" is to place the lettered diagram in a position where it may be easily seen, and begin setting type by its aid. Certain letters, such as b, d, p, q, will confuse at first. These letters may be known by remembering that type b looks like printed p, and d like q, and visa versa.

JUNIOR DEPARTMENT

For the Instruction and Information of Younger Readers.

A MODEL STEAMBOAT

CARL H. CLARK.

The boat illustrated is similar in style and shape to the fast steamers running on the ocean. It is designed to be 50'' long on top, 8'' wide and 6'' deep at the lowest point and should draw about 3'' of water when in trim. She is straight along the bottom to the point where the stem begins to slope upwards; this point is 8'' from the bow. The overhang at the stern from the sternpost is 3''. The length of the stern above the keel is 6 1/2'' and that of the bow is 8''.

except that it will probably be impossible to obtain a single piece of timber large enough, and several thicknesses will have to be glued together to get the necessary depth. Considerable labor in hollowing out will be saved by sawing a piece out of the centre of each lift before gluing together. The gluing must be very carefully done to stand water, the surfaces of the lifts must be smooth and even and they must be pressed closely together while the glue is drying. The model should not be hollowed out to less than 1'' thick as some wood must be left to give the necessary strength and give surface for the glue to stick to.

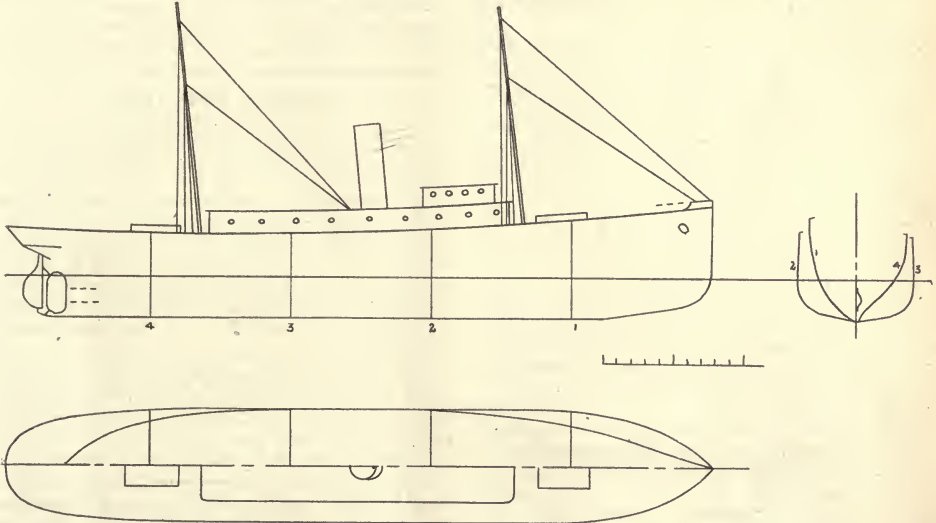

The shapes of five sections are given 10'' apart, numbers 2 and 3 are alike, 1 and 4 may be scaled from the sketch by using the given scale and a pair of small dividers. The sides amidships should have a slope towards the middle of about 1/4'' from the waterline up that is, she should be about 1/2'' narrower on deck than at the waterline. The waterline forward should be quite sharp and at the stern should be rather more rounded. The best way of getting at just the shape under the stern would be to go and observe some steamer. In this way one could get a far more accurate idea than could possibly be given by any description.

The method of construction of the hull is the same as that given in the articles on the sailing models,

The opening for the propeller is about 1 1/2'' wide and 3'' high, and should be cut out after the model is finished outside. Along the dotted lines at the stern, a round swelling should be left about 1/2'' in diameter, to allow the shaft to come through. The sternpost is made of a separate piece joined to the rest on the diagonal lines shown. The rudder may be of either wood or metal, about 2'' wide. The small bulwark forward is made of two pieces of thin wood about 1/2'' high and is put on afterwards. The deck should be of about 1/2'' stock and should be set in carefully so as to be flush with the upper surface of the hull. It should have a slight forward curve. It will be best not to fasten the deck in firmly until the machinery has been fitted. The deckhouse is about 24'' long, and 5'' wide

and 1 ½" high, so shaped as to make space between it and the side of the boat even all the way around. This deckhouse may best be a sort of box built up out of thin stock, to be light. The top should extend over about ½" at the sides and ¼" on the ends.

The house should be removable and should fit over a little ledge built on the deck. This ledge will hold it in position and keep water out. Some means must be used to fasten it on securely. This allows the examination and adjustment of the machinery, as the deck is cut away under the house. The pilothouse is about 5' long, 4' wide and 1 ¾" high, fastened on the top of the main house. The masts are ¾" diameter at deck, about 18' long, and are stayed as shown. The foremast extends down to the bottom of the hull, but the mainmast will land on some kind of brace built up over the propeller shaft. The stack is 6" long and above house 2" diameter, rolled up out of tin and painted black. It is fastened to the deckhouse and should extend down over the outlet of the boiler, to carry off the heat.

If it is intended to float the model in water it must be very carefully painted inside and outside. The general details, such as rails, hatches, and rigging can best be figured after a visit to some vessel, or a scrutinizing of pictures of vessels. There are several other methods of building a model if one is expert enough. A model of this size could easily be planked upon mould in the same manner as a large boat. They are also sometimes made of paper, thin sheet metal, or other material. A railing of wire should be carried around the model, starting from the small bulwark upwards as shown by the dotted line.

The house holes are carefully bored and finished. If desired, batches can be made in the deck about 4" x 4", and fitted with covers. A great many details may be worked in if desired, small anchors and chains may be made or purchased. A steering gear may be devised, small metal ventilators may be fitted. Derricks may be fitted on the masts, small boats can be placed on the deckhouse, and numerous other additional things will suggest themselves as the work progresses. We have seen models of this size which when well fitted up, were worth considerable money. The description of a steam turbine of proper size for this boat is given in this issue, and a model steam engine is being prepared.

CORRESPONDENCE.

No. 68. LAKEWOOD, O., Nov. 17, 1903.

I would like to operate a wireless telegraph a distance of about eight miles. Will the apparatus described in the June and July numbers of 1902 be sufficient? If not, what changes should be made?

Please explain the system of wireless telegraphy or telephony using the earth alone as a conductor, and refer me to a book on same.

A. J. H.

Wireless telegraphy instruments capable of transmitting messages over a distance of eight miles would have to be much more elaborate and expensive than those described in the June and July numbers of this magazine. The coil would require to be much larger and giving an eight to ten inch fat spark being necessary. The relay would also have to be of very high resistance, about 1000 ohms. Relative to telegraphy or telephony, by using the earth for transmitting the currents; much more work as has been done in this line has not been very fully described in the technical papers, so that the methods used could be fully determined. Information on this subject will be welcomed for insertion in this column.

No. 69. DORCHESTER, MASS., Nov. 30, 1903.

Please give me a receipt for invisible ink, to be made visible by means of some chemical solution?

C. E. B.

A thin solution of arrowroot, used with a stub pen on rough paper, is developed by placing in steam of a weak solution of iodine in water, heated in a dish upon a stove. It fades again upon drying, but may be revived several times in the same way.

BOOKS RECEIVED.

TOOLS AND MACHINES. CHARLES BARNARD. 158 pp. Price \$1.25, Silver Burdett & Co., Boston, Mass.

As an introduction to the study of tools and machines and their uses, teachers of Sloyd and the first grades of Manual Training will find this a serviceable desk book. The clear and attractive way the subject matter is presented, makes it readily usable for reading exercises, and for this purpose can be warmly commended. Detail directions for the use of tools are not given, its purpose not being to serve as a manual. 62 Illustrations.

THE TEACHERS HAND BOOK OF SLOYD. OTTO SALOMAN. Translated by Mary R. Walker and William Nelson, Second Edition. 264 pp. Price \$1.50 Silver Burdett & Co., Boston, Mass.

The teacher of Sloyd who does not have a copy of this book within easy access should get it at once. Its presentation of the educational ideas upon which this system of instruction is based, are so clear that the attentive reader cannot fail to gain a good perspective of the whole system, as well as a large amount of detail relating to the numerous exercises given. Over 130 illustrations supplement the text.

PRACTICAL LESSONS IN ELECTRICITY. Four parts. Different authors, 254 pp. 70 cents. American School of Correspondence, Chicago, Ill.

The purpose of this volume is to give the public an opportunity to judge of both the standard and scope of the correspondence instruction offered by this school, but contains much practical information making it of value to both the practical electrician and also the amateur. Readers of this magazine interested in electricity will find the book of value, and are cordially recommended to obtain it.

AMATEUR WORK

A MONTHLY MAGAZINE OF THE USEFUL ARTS AND SCIENCES

Vol. III. No. 4.

BOSTON, FEBRUARY, 1904.

One Dollar a Year.

ACETYLENE GENERATOR FOR MAGIC LANTERNS.

The acetylene generator here described is of ample capacity for providing sufficient gas for an evenings use of the magic lantern described in the previous number of this magazine. It is perfectly safe to operate, if the ordinary precautions attending the use of any illuminating gas are observed. Granulated carbide is used of about $\frac{1}{4}$ " screen. The pressure is easily regulated by weighting the bell *B* with rings of bar iron large enough to slip down over the carbide chamber *C*.

The tank *A* is made of fairly heavy galvanized or tinned iron, and is 18" high and 15" diameter. To the outer sides are soldered two pieces of $\frac{1}{4}$ " round iron rod *g* 12" long, which serve as guides for the bell *B*. A piece of $\frac{1}{4}$ " iron pipe *D*, 22" long is bent 16" from one end, put through a hole punched in one side of the tank, and carefully soldered rigidly in position, where it passes through the tank and by means of a brace *d*, bent as shown and soldered to the bottom.

The main part of the gas bell *B* is also made of galvanized iron and is 15" high and 12" diameter. The top is a disk with a centre hole, 4" diameter, cut through, and to the edges of which is soldered the tube *F*. The guides *D* of iron are also soldered to the top of bell, and are 5" long, and 1" wide; holes $\frac{3}{8}$ " diameter being punched 1" from the ends for the rods *g*. Across the bottom a guide *f* for the plunger rod is fitted. It is made of hoop iron, 14" long, and 1" wide, 1" at each end being turned up and riveted to the sides of the bell. The $\frac{1}{16}$ " hole should be in the exact

centre. The guides *k* are fitted to the lower, outer edge of the bell, serving to keep it centered in the tank. The guides should be about $\frac{1}{8}$ " scant of meeting the sides of the tank. They

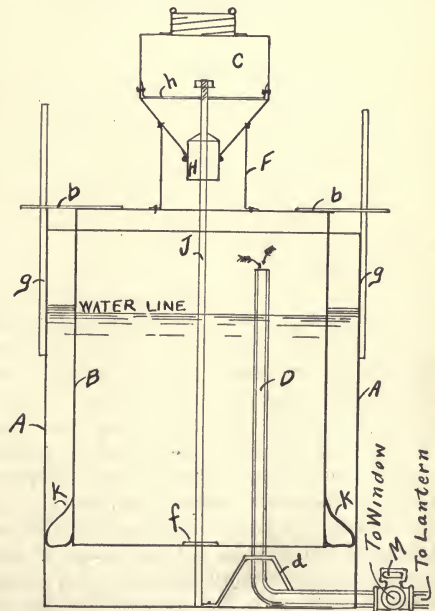

are made of strips of hoop iron 6" long and 1" wide bent to the shape shown and riveted to the bell, the lower end being riveted first and before bending.

The tube *F* is also made of galvanized iron and is 4" diameter and 4" high, the joints with both the bell and carbide chamber, *C* being strongly made and well soldered. The carbide chamber *C* likewise made of galvanized or tinned iron is much after the shape of an inverted oyster or milk can, only of larger size, and with a 3" opening in the top fitted with a screw cover, similar to those used on preserve tins, which must be gas tight. This will undoubtedly have to be made up at a tin shop, but will not be expensive.

The bottom slopes inward at an angle of 50°, the hole in the centre making a close sliding fit to the plunger *H*, which is 1 $\frac{1}{2}$ " diameter. A strap *h*, 8" long and 1" wide, with the ends turned up 1", is fitted across the chamber as shown, a $\frac{5}{16}$ " hole in the exact centre acting as a guide for the plunger rod *J*. If possible, have the edge of the hole at *H* turned around a wire bail to give strength and stiffness. Certain forms of coffee tins fitted with screw tops, are obtainable in large cities, which could be cut down and fitted with the V shaped bottom, saving considerable work.

The plunger is made with a piece of $\frac{1}{4}$ " round iron rod, or cold drawn steel would be better, 24" long. A thread for a nut is cut on the top end for about 2". The part *H*, is made by first turning up a cylinder 2 $\frac{1}{2}$ " long of hard wood, like birch or maple, with a pointed top to prevent the carbide from lodging there. Around the straight part of this wooden cylinder, fit a piece of tinned iron, the joint being a soldered butt joint, filed smooth after soldering to slide freely in the opening in the bottom of the carbide holder. When these parts are completed, put the plunger in place and see if it slides freely and accurately. The top of the straight part of *H* is about 2 $\frac{1}{2}$ " from the upper end of the rod. The plunger should fit so that when pushed up against the strap *h* an opening of about $\frac{3}{8}$ " is left between the bottom of *H* and the sides of the holder.

To the outer end of the feed pipe *D* is fitted an independent gas cock *M*, and just outside of this a straight pendant cock, to the outer end of which is fitted a male soldering nipple. The rubber gas tubing to the lantern is fitted over this nipple. Another piece of tubing is run to an adjacent window from the end of the independent cock, this being used to let off any excess of gas

which might be generated by the dropping of considerable carbide. Should the plunger show any tendency to stick during operation and not close readily, bore holes in the wooden cylinder and run in molten lead; the additional weight will prevent this, or the part *H* can be made of a solid piece of cold rolled steel shafting, a hole being drilled through the centre for the rod *J*.

The operation of the generator is as follows:—The tank is filled with water to a depth of about 12", the bell placed in position, and held from dropping to the bottom of the tank by placing pieces of wood under the guides *D* and resting on the top of the tank. The cover of the carbide holder is removed, the required quantity of granulated carbide, $\frac{1}{4}$ " screen, placed in the holder; the cover immediately replaced and screwed firmly down; the sticks removed from under the guides thus allowing the bell to sink; the rod *J* resting on the bottom of the tank, causes the plunger *H* to open as the bell settles and a small quantity of carbide drops into the water; gas generates causing the bell to rise so that the plunger closes the opening in the bottom of the carbide holder, and the feed of carbide ceases until enough gas has been consumed to cause the bell to again drop low enough to again open the feed hole. When generation first begins, open the cock *M* to allow the air in the holder to escape, closing it when acetylene begins to flow. When through using, if the carbide is about used up, take into the open air and empty, using care that no lamp or other flame is near at hand. An electric hand-lamp is the best thing for such work.

A remarkable phenomenon is reported at St. Petersburg, from the rural commune of Schava, in the Government of Tsarey. Inexplicable noises were heard for several days issuing from the earth. The sounds varied from something like the booming of cannon to the screeching of steam whistles, and seemed to come from a forest skirting the commune. In this forest, where the terrified peasantry gathered in expectation of some great calamity, the earth was seen to heave incessantly. Gradually huge cracks appeared, the earth seemed to sink, water rose, and there came to view a new lake, of considerable extent, which is now being examined by geologists.

LANTERN SLIDE MAKING.

R. G. HARRIS.

I. Introduction—Slides by Contact.

The object of these chapters is to place before the slide worker a general review of the standard process for the production of slides, with descriptions of reduction and contact methods, and details of such accessories as may be deemed most useful to the general worker. For the benefit of those who have yet to make their preliminary trials in lantern slide work the subject will be treated *ab initio*, without assuming even an elementary knowledge of the process on the part of the beginner. Later on, processes will be described that appeal more directly to the advanced worker and to the lantern slide enthusiast; processes that are viewed by many simply with historical interest, and yet are capable of giving the finest results when facility in their working has been acquired. Albumen, collodio-bromide, wet collodion are processes that few modern slide makers connect with lantern transparencies, yet for downright quality no modern process can claim superiority over the time honored albumen, and slides of Ferrier's of thirty years ago hold their own when compared with the best work of today. Wet collodion, in capable hands, is still the process *par excellence* for obtaining crisp, bright results with a minimum expenditure of time and trouble, and collodio-bromide has the merit of having fixed a standard of excellence for the modern gelatine lantern plate.

A question the beginner in lantern-slide work will most probably ask himself is, "What constitutes a lantern-slide?" He is, most probably, already in possession of the fact that, in the negative he has taken, the lights and shadows of the original are reversed and that to obtain them as they existed in the original it is necessary to get from the negative a print which gives the lights and shadows of the original as they were seen by the eye. This "positive" print on paper will be viewed by "reflected" light, i. e., by light reflected to the eye from its surface. If the gelatine film of a P. O. P. print was stripped from

its paper support the "positive" image would be seen to exist in this film, but as there was no longer any white background paper to reflect the light through this image it could not be seen as a positive. Suppose this film was now laid upon a clean piece of glass and pressed firmly and evenly into contact with it, on being held up between the eye and a clear view of the sky the positive appearance would be restored and the picture would again be seen as plainly as when it was supported on the white paper. The film, in fact, has now become a lantern slide, but instead of being made apparent to the eye by light *reflected from* the white paper support, the eye sees the picture by light *transmitted through* the film from the background of the sky. It will be obvious, then, that fundamentally there is no difference between the paper print and the lantern slide, but that the one is, for convenience, placed upon a white paper support while the necessity for using transmitted light in the optical lantern demands that for a lantern slide the image bearing film be borne upon a transparent support.

It follows from what has been said that lantern slides can be printed from the negative in just the same way as an ordinary silver print, provided that the same sensitive material is used upon glass instead of upon paper; the image could afterwards be toned and fixed as though it were a paper print. At one time, considerable lantern slide work was done in this manner, as the image becoming visible during printing, offered facilities for modifying it not available when the image required developing. The inconvenience of using an inflexible support in the printing frame, which prevents a ready view being obtained of the depth of the print, coupled with the slowness of the process, debarred it from attaining any permanent popularity. At the present time lantern slides are produced almost exclusively on the lantern plates of commerce.

The exposure of a lantern plate may be either

by "contact" or by "reduction." Suppose the worker employs a quarter plate hand camera for taking the negatives, he can make his lantern slides by placing the negatives in the printing frame as used for paper, adjusting his lantern plate upon the negative, film to film, closing the frame and exposing to gas light for the necessary time. In this case he is working by "contact" and as the size of a lantern is $3\frac{1}{4}'' \times 4''$, while the quarter plate is $4\frac{1}{4}'' \times 3\frac{1}{4}''$ it follows that, when working by "contact" some portion of the original negative has to be omitted.

It is frequently the case that when working from hand camera negatives some portion of the original negative can be omitted without detracting from the value of the picture, but where larger sized plates are used, half plates and upwards, contact printing is out of the question unless some very small portion of the original is desired. When it is desirable to make lantern slides from negatives which are of much greater dimensions than the lantern plate the slides are got by reducing the original size of the negative, by means of the camera, until it shows on the focussing screen the same size as the lantern plate. A lantern plate being placed in the dark slide and exposed to this image will result in a lantern slide that embraces the whole of the subject that is in the larger negative. This constitutes the method of work known as "reduction." Later on full description of these two methods of working will be given, with the apparatus necessary in each case.

Some workers of experience contend that finer results are got when making slides by reduction, even in the case of quarter plate negatives. I am inclined to think that such is the case, though the gain in quality is not sufficiently striking to impress a beginner.

One decided advantage camera reduction has over contact printing is that, should any unevenness be present in the surface of either negative or lantern plate, the definition is not impaired. "Contact" printing is certainly the simplest form of exposure for the beginner, and as it can be conducted without any special apparatus, as it is entirely independent of daylight and with some lantern plates, even of the customary dark room, it is the method that will receive the first consideration in these chapters.

Before commencing any description of the methods whereby lantern slides are made, it may be well to caution the beginner against depriving himself of sufficient light in the dark room. The sensitiveness of lantern plates is so greatly inferior to that of plates used for negatives that it will take the beginner in lantern slide work some time before he acquires the courage to use all the light permissible with these slow plates. Some lantern plates are so slow that they can be manipulated in the light of a naked bat's wing burner, if it be turned down, and the plates are not exposed unnecessarily to its light. With the ordinary lantern plate, made for reduction and contact work, the light of a paraffine lamp screened by two thicknesses of canary medium will give a light that is both safe and comfortable. It is convenient to have between the fabric and the lamp burner a sheet of finely ground glass which affords a very pleasant diffused light whereby to judge the density of the slide. It is convenient also, on taking the slide from the fixing bath to raise the cherry colored fabric and have the greyed surface to examine the slide by.

The negative for contact printing, which will probably be of quarter plate size can be placed in a quarter plate frame such as is used for paper printing; it is carefully dusted with a broad camel hair brush to remove anything that might injure the film of the lantern plate. This latter is then placed upon the negative, the film of the lantern plate against the film of the negative. The lantern plate should not be slid into position over the surface of the negative or damage to the film may result; it should be placed deftly into the position it has to occupy without any need of readjustment when laid down. The back of the frame should be placed in position and fastened by the springs. It must be remembered that the thickness of the lantern plate will cause considerable pressure if the felt pad used in paper printing is employed here also, and usually quite enough pressure to insure contact will be got without using the pads.

Having fixed the lantern plate in the frame it now requires exposing to light. Daylight is practically out of the question, as in spite of the relative slowness of these plates, they are still sufficiently rapid to make daylight exposures un-

manageable. The most convenient light is a gas burner, and if it has a bypass, exposures can be readily made in the dark room without loss of time. We must bear in mind the fact that in lantern slide work long exposures give warm colored slides (the developer being suitably adjusted) and short exposures black tones. Suppose five seconds' exposure at a given distance from a bat's wing burner gives a lantern slide of black tone, then with half a minute's exposure at the same distance the slide will have a brown color, and with a minute's exposure the color will be decidedly red. The developer would require modifying in each case to suit the increased exposure. Producing satisfactory warm tones in lantern slides, at the same time retaining other desirable qualities, demands more experience than making a slide having a black color, and such being the case, the beginner is recommended to adhere to the production of black colored slides until he can make them with ease and certainty.

A negative of medium density, held about eight-inches from a bat's wing burner would require an exposure of some six seconds for black colors, when the ordinary lantern plate was used, and developed with the formula given below :

Amidol	20 grains
Sodium sulphite	240 grains
Potassium bromide	10 grains
Water	10 ounces

Development is very rapid, much more rapid than would be the case with a negative, and the beginner has to be on his guard against obtaining excessive density. The exposure must be so timed that when development is complete, the highest lights of the picture have no veil over them, this can readily be seen after the plate has been fixed if the slide be laid upon a sheet of white paper. The paper should show through the high lights perfectly white, otherwise a crisp picture, when the slide is projected upon the sheet, cannot be hoped for. As soon as density has been obtained in the developer the slide is placed in the fixing bath, made as follows :

Sodium hyposulphite	2 ounces
Sodium bisulphite	$\frac{1}{2}$ ounce
Water	10 ounces

This is a brief description of the making of a lantern slide, and the beginner is recommended to persevere with the above simple method until he can produce slides of good quality.

Photography.

CHEMICALLY COLORED LANTERN SLIDES.

Mrs. C. R. MILLER.

Over a year ago, *Western Camera Notes* published the following formula for the toning of lantern slides, that is, giving a wide range of tones in brown, red, blue and green.

BROWN AND RED TONES.

A. Uranium Nitrate	40 grains
Water	1 ounce
Acetic Acid	20 drops
B. Potassium Ferricyanide	25 grains
Water	1 ounce

To 6 drams of water add 1 dram each of A and B. When toned to the desired color wash in slightly acidulated water until the greasy appearance is gone. It must be borne in mind

that this bath intensifies the slide, which should therefore be made somewhat thinner than desired.

BLUE TONES: The red tone obtained by the Uranium bath may be changed to greenish blue by immersion in the following bath :

Ferric Chloride	5 grains
Water	6 to 10 ounces

A slightly greener tone is obtained by the use of the following bath :

Iron Protosulphate	20 grains
Cold water	1 ounce
Sulphuric Acid	1 drop

The following will give blue tones :

A. Ammonio Citrate of Iron	4 grains
Water	1 ounce
B. Potassium Ferricyanide	4 grains
Water	1 ounce

When dissolved, add A and B and then add Nitric Acid 10 per cent solution 5 drops. After toning wash in a gentle stream of water to clear the "white."

To my mind this should have at least created some comment among lantern slide workers. Yet after waiting patiently for nearly a year I have read of none who have tried this most excellent method of relieving the monotony of black and white slides.

It takes an artist of steady nerve and rare ability to tint a lantern slide which will not prove a freak when shown upon the screen. As few of us can lay claim to such talent, the next best thing to do is to find some way of making them attractive by chemical toning. A few days after the magazine arrived I brought out some weak slides which has been thrown aside to be washed for cover glasses. I mixed up the Uranium and Ferricyanide toner and after thoroughly soaking the slide in water, I placed it in the chemical tray. In a few minutes the effect was like magic. The old faded-looking plate came out of its bath a rich red brown. After washing thoroughly, and care must be taken to do this properly, the slide was dried and thrown upon the screen. It seemed to me that detail which never showed in the photograph appeared upon the canvas. Delighted with its success, I later tried the other formula above mentioned with the same good effect so much desired for lantern slides.

I called in my photographic friends and they all agreed the effect was beautiful. Several of these are now using the same chemicals in like manner. Care must be taken not to allow the toner to settle in spots on the plate and it is best to do one at a time and keep it moving. Then, too, remember to soak the slide well before placing it in the coloring tray, otherwise the chemicals will not attack the coating evenly and a freak slide will be the result. Be sure to keep your chemicals in a dry place, especially the Ferric Chloride, which, if exposed to moisture any length of time before mixing becomes valueless. Glass stoppered bottles should be used for all.

The beginner must be prepared to spoil a number of slides, but the result after a few trials will prove highly satisfactory. I have been interested in lantern slide work for a number of years and have between six and seven hundred. It has been my pleasure to try many ways of coloring and various toners, but the formulas reproduced above is by far the best of them all. The slides have been tried under all sorts of light, coal oil, gas, calcium and electricity and the coloring out with equally beautiful effect. I have more than one hundred views of the picturesque parts of Colorado toned in this manner. The chemicals have been so manipulated as to reproduce the exact shade of the wonderful Rocky Mountains. Occasionally a freak slide will result from improper washing or a mixture of chemicals. Yet they even are not always lost. Some of them are really very pretty, giving the effect of double staining.

It has been suggested to me that "whatever intensifies will also fade." That may or may not be true. My slides have been exposed to strong light and not a little dampness, yet they are as fresh as the day they were made. I cannot see why they should change color or fade out, and I do not believe they will. However, should such be the result, I would remake the entire lot using the same toners.

The plates to be colored by the method of which I have spoken may be of any good make, and developed with the developer which pleases the photographer. The chemicals work equally well on all brands of plates. After all, the real joy of amateur photography is in lantern slide work. Magic lanterns are cheap and easily rigged up in a private house. You may show your pictures with good effect to your friends, and if you are any sort of a talker (amateur photographers generally acquire that habit) you may add to your income by appearing at church and school entertainments and in this way make your art, whose only fault is expense, pay for itself. If you do not care to be reimbursed for your work, you will be all the more popular and "twere good you do so much for charity." To successfully give an evening's entertainment the slides must have merit, show good detail and be made attractive by some little coloring.

Western Camera Notes.

BATH-ROOM CABINET.

JOHN F. ADAMS.

As the bath rooms of modern houses are seldom provided with cupboards wherein medicines and toilet articles may be kept, the cabinet here described will be found a most convenient piece of furniture for such uses. The wood used for making it should be that which will most nearly match the finish of the room, unless a decided contrast is desired, in which case, oak with weathered oak stain gives a good effect.

As shown in the illustration, the shelves have tongues projecting through the side pieces, with wooden pins placed in holes cut therein, but the cabinet can be made without them, grooves being cut in the side pieces for holding the ends of the shelves. The stock used should be $\frac{3}{4}$ " or $\frac{7}{8}$ " thick, the curved cuts at the foot of the side pieces being made at the mill where the stock is purchased, and are 5" high and 8" wide at greatest diameter.

The side pieces are 45" long and 15" wide. A piece 5" wide and 16" long is cut out of the front of the ends forming the upper part. The top and shelves, excepting the one in the upper part, are 24" long over all, the top being 13" wide the, shelf in the lower part 12" wide, and the bottom board of the lower cupboard, 15" wide. The under back edge of the top piece, and the upper back edge of the bottom piece have $\frac{1}{2}$ " rabbets cut therein for the $\frac{1}{2}$ " sheathing at the back. Two pieces 2" wide and 21 $\frac{1}{4}$ " long, are needed, one under the bottom of the cupboard at the front, and the other forming the front edge of a rectangular frame under the drawer. The shelf for the upper cupboard is 22 $\frac{1}{4}$ " long and 10 $\frac{5}{8}$ " wide, the front edge forming a stop for the drop lid. A groove for this shelf $\frac{1}{2}$ " deep is cut in the side pieces, 4" from the top ends of the letter. All the shelves are set $\frac{1}{2}$ " in from the back edge of the side pieces to give space for the $\frac{1}{2}$ " sheathing of the back. The shelf above the drawer has only one tongue on each end projecting through the side piece, the front edge forming a projecting at each end 4" wide, the inner edge meeting the front

edge of side piece. The drawer is 4" deep, requiring for the front a piece 21 $\frac{1}{4}$ " long and 4" wide, two side pieces of white wood $\frac{1}{2}$ " thick, 4" wide and 14 $\frac{1}{2}$ " long, and a cross piece at the back 21 $\frac{1}{4}$ " long, 3 $\frac{1}{8}$ " wide, and $\frac{3}{4}$ " thick. Rabbet the ends of the front and back pieces to receive the ends of the side pieces, and the lower edges of all the pieces to receive the bottom board 20 $\frac{3}{4}$ " long, 14" wide and $\frac{1}{4}$ " thick. The frame to support the drawer is made of pieces 2" wide, the ends being halved, except that for the front piece which is not cut clear through to the front edge.

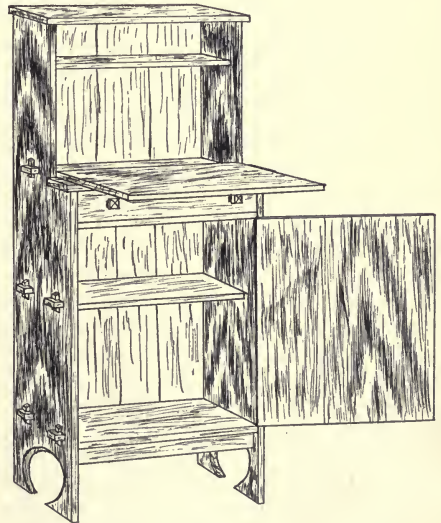

The tongues projecting through the side pieces are 1 $\frac{3}{8}$ " long and 2" wide, the holes for the pegs being $\frac{3}{8}$ " square. The outer edges of the tongues are 3" from either edges of the side pieces. It will be best to cut the holes first and then locate and cut the tongues. The pegs are 2" long. The lower holes are 6" from the floor, those for the shelf above, 17" from floor; the hole

for the shelf above the drawer lines with the cut previously mentioned. The drop lid for the upper part is $21 \frac{1}{4}$ " long and $15 \frac{1}{8}$ " wide. To keep this from warping, rabbet the inner edges of the ends and glue on strips 2" wide and $\frac{1}{2}$ " thick, which are not shown in the illustration. If perfectly dry stock is obtainable, and same planed on a jointer to take out the wind, these strips can be omitted. The hinges are hung on the lower edge, and do not show. A spring catch at the

top keeps the lid closed.

The door for the lower part is $17 \frac{1}{4}$ " high and $21 \frac{1}{4}$ " wide, the grain running vertically, consequently it will have to be glued up from two pieces. It is hung with hinges suitable to the wood used and finish, hooks for hot water bottle, etc., being placed near the top on the inside. Suitable catches are fitted, and locks also are desirable if small children are likely to make tests of the medicines there stored.

MICROSCOPY FOR AMATEURS.

S. E. DOWDY. M. P. S.

IV. Testing the High Power Lens.

Microscope lenses are subject to three principal defects. They may show spherical aberration, chromatic aberration, or want of flatness of field. For the causes and means of remedying these faults the student should read up an elementary book on optics, as it is only misleading to attempt to explain the why and wherefore of these characteristics of a defective lens in a few words. They are due, if present in an objective, to faulty workmanship, and should, therefore, act as danger signals, warning a prospective purchaser from acquiring the lens in question. I am, of course, referring to what are generally known as "achromatic" lenses, such as are in general use, and not to the recently introduced series of lenses known as "apochromatics," the outstanding corrections of which are made by special compensating eyepieces. The presence of marked spherical aberration in an objective would be shown by the impossibility of getting a perfectly sharp image of an object, the margins of which would apparently be hazy, even when the lens should apparently be in focus. Chromatic aberration makes its presence known by imparting a halo or colored fringe to the outlines of an object seen through any lens possessing this undesirable property. Flatness of field is present if objects lying in the same plane are in sharp focus, in whatever portion of the field of view they may be. For instance, if we were looking at a piece of paper with very minute printed matter upon it, using,

say a 1 inch lens and a low-power eyepiece, and the print in the centre of the field was a sharp focus, that at the edges should also be so without altering the focus; otherwise the lens does not possess a flat field, which is an important desideratum in a low-power lens. Owing to vastly improved methods of manufacture, both English and Continental makers are now supplying students with well-corrected lenses at a low price. Glaring defects are, therefore, not often to be met with, and the student is hardly likely to meet with good examples of either chromatic or spherical aberration when testing his lenses, provided they are by a maker who has a reputation to maintain. Still, lenses constructed from even the same formula will vary to a certain extent, so that it is as well that the beginner should have a general idea of how a lens may be tested. If really interested in this branch of the subject, he should obtain two or three uncorrected lenses, of varying convexity, which, with the help of the aforementioned book on optics, can be made the groundwork for several very instructive experiments bearing on spherical and chromatic aberration. After a few such experiments with stops and diaphragms of various kinds, he will better understand the value of the aperture and other important parts of his objectives.

We now come to what, for the beginner, will prove a slightly more difficult matter, viz., the testing of his high-power lens. For simplicity's

sake I assumed that in testing the low-power lens, the student dispensed with the use of a substage condenser. It is impossible, however, to fairly test a high-power lens with such an inadequate illumination as that obtained by using the mirror alone. A few words, therefore, as to the method of obtaining suitable illumination with the condenser will be necessary. Most substage condensers supplied with students' instruments are what are known as Abbe illuminators, or Abbe chromatic condensers, to distinguish them from the Abbe achromatic condensers, which have carefully corrected lenses.

As the student will have no difficulty in understanding, condensers are subject to the same defects as objectives. They may, and usually do, possess both spherical and chromatic aberration, but whereas these properties in a lens would be quite sufficient to immediately condemn it, much useful work may be done with an Abbe chromatic condenser of the useful student's type, in spite of their presence. For the finest results in high-power critical work, microscopists use condensers achromatised, possessing what are termed large aplanatic apertures, but it requires a trained observer to mark their superiority over the less pretentious substitute supplied with student's instruments. When the beginner is in a position to appreciate this undisputed superiority, it will be time for him to think of exchanging his uncorrected Abbe for one of a higher type.

To return, however, to our main project, the testing of our high-power lens, which will most probably be either a $\frac{1}{4}$ " or $\frac{1}{8}$ ". In the first place, to give the objective a fair trial, good illumination must be first secured, then a suitable test object placed on the stage, proper focussing effected, and allowance made for thickness of cover-glass surmounting the specimen. The tube length employed must also be the one for which the lens was corrected.

The necessary information as to thickness of cover-glass and tube length will, as a rule, be found in the maker's catalogue, or else furnished on application; and, if possible, the test should be made complying with these conditions. The better-class high-power dry lenses are furnished with a small adjustment, called a correction-collar, to allow for varying thicknesses of covers; but a similar result can be obtained by the stu-

dent by slightly altering the length of the draw-tube.

To secure suitable illumination, the low-power lens should be first on the instrument, and the low power eyepiece used with it. The small paraffin lamp is placed on the left side of the observer, and light from it is flashed up by the mirror. A fine ground-glass slide is now placed on the stage, and focussed with the objective. The lamp flame is now turned edge on to the mirror and the condenser is racked up until an image of the flame appears sharply defined on the ground glass. If this image is not exactly in the centre of the field, it must be made so, either by using the centering screws with which most condensers are fitted, or else by slightly altering the position of the mirror or lamp.

We now have what is known as critical illumination, and the object to be viewed is brought into this brilliant image of the lamp flame after first removing the ground glass slide. As only a very small portion of the field is thus illuminated, this method is only suitable for testing resolving power and definition of the lens. The beginner had better, therefore, first obtain this critical illumination, and then rotate the lamp till its flame is broadside on to the mirror. The condenser should then be slightly racked down out of focus until the whole field is brilliantly illuminated. Now remove the eyepiece and look down the body tube and see how much light is entering the objective. To get good results, the back-lens should appear about two-thirds full of solid cone of light, and this must be obtained either by opening or closing the iris diaphragm, or placing a smaller or larger stop in the condenser. If possible, the condenser should be fitted with an iris diaphragm, which consists of a series of thin metal plates so arranged that by moving a lever they can be made to open or close up to give any desired aperture.

We can now replace our eyepiece, and a good illumination for testing the general value of a lens will be obtained. The very finest definition is theoretically and practically obtained by easing the edge of the lamp-flame, viz., critical light, but for the beginner's purpose a fully illuminated field will be preferable. I might mention here that if the low-power objective is being used the condenser will enhance its performance. In this case, however, the top lens of condenser must be

taken off, and, if possible, a circle of ground glass be placed in the stop carrier with which a condenser is usually furnished, so as to moderate the light. To return to our $\frac{1}{4}$ " or $\frac{1}{8}$ " lens, however, we shall now require a test object. The silicious valves of a species of organisms known as diatoms are generally employed for this purpose. These valves are mostly marked with a series of very fine, what will probably appear to the beginner as lines, but which under proper conditions assume more the appearance of short strings of beads or dots. The capability of the lens to show these markings as separate dots constitutes its resolving power, which is slightly dependent upon its aperture. In *skilled hands*, therefore, these tests objects are most useful indicators of the value of the lens being used; but as a knowledge of the nature and physical characteristics of the object itself, and also the best methods of illuminating it to bring out these details, is essential to success, it would be better for the tiro to pick out an easier object. If, however, he can obtain what is called a spread slide of mixed diatoms, he could use it to advantage in the following way. Having placed it on the microscope stage, he should first of all select a medium sized diatom under the low power, and bring it quite in the centre of the field. He should then substitute the higher power, focus it carefully, and see if the markings upon the diatom valve are shown in fine lines under a low-power eyepiece. If this is the case, the diatom will most likely be a suitable one for testing the lens, because on substituting the higher power eyepiece, and manipulating the mirror so as to obtain oblique light, these lines may be split up into strings of pearls or beads. This result will depend entirely on the aperture of the lens, its perfection, and the skill of the observer in obtaining correct illumination. As the fineness of these markings differs considerably, even in the valves of the same kind of diatom, it follows that such a test must be a comparative one. Suppose, for instance, the observer can obtain the loan of a really good lens of *similar aperture* to his own, and can try comparison tests with his own lens on the same diatom, it will afford him a pretty good guide as to the capabilities of the one he has purchased. In passing I might mention that to obviate the variability in the fineness of the mark-

ings on diatom valves, test slides are often substituted artificially ruled with lines of such extreme closeness and exactness of individual distance apart that it requires very high magnification and big apertures to show them as separate lines. These slides, however, are beyond the province of the beginner, but are interesting examples of human skill and ingenuity. To turn, however, to an object that can be judged with greater facility. Such a one would be found in the object used for testing the 1" objective, viz., the wing of the housefly. It must be viewed with critical illumination, using both low and high-power eye-pieces, noting carefully the appearance of the fine hairs fringing the edge of the wing. These should stand out sharp and clear, free from haze and color. Flatness of field, which, however, is not such an important property in a high-power lens as it is in one of the longer focal length, can be judged by racking down the condenser until the whole field is full of light, and then noting the sharpness of definition of the wing membrane at the sides of the field as compared with that in the centre. In using high powers an approximate focus should be obtained with the coarse adjustment, critical sharpness of image being obtained by using the fine adjustment without removing the eye from the eyepiece. Light rotation between finger and thumb of the milled head of the fine adjustment is all that should be necessary to impart a smooth, low movement, with freedom from lateral displacement of the image. A good general test object for our high-power lens, and one easily obtainable, is a drop of fresh blood. This can be easily obtained by tying a handkerchief tightly round the forefinger, which should first of all be held downwards for a short time, and then pricking the tip of the finger with a perfectly clean fine needle. In pressing the finger, a minute drop of blood will exude, and this is transferred to a slide as follows:—A thin clean 3" x 1" slide is placed on a piece of notepaper, and a thin cover-glass is put on its centre. The blood-drop is then touched against the edge of the cover-glass, when capillary attraction sets in, and a thin film of the liquid is drawn under, and is then ready for examination. When viewed with a $\frac{1}{4}$ " or $\frac{1}{8}$ " lens, human blood is seen to consist of numerous rounded biconcave corpuscles floating about in a colorless liquid. On closer

examination a few larger colorless or greyish corpuscles will be seen, these being the so-called white, the others the so-called red corpuscles of the blood. The sharpness of outline of the margins of the red corpuscles should be carefully noted, and a general view of the field taken before arriving at any conclusions as to the value of the lens.

BOOKS RECEIVED.

INTRODUCTORY COURSE IN MECHANICAL DRAWING, J. C. TRACY, C. E. AND E. H. LOCKWOOD, M. E., AMERICAN BOOK CO., BOSTON, 155 pp. $10\frac{1}{2} \times 7\frac{1}{2}$ INCHES, \$1.80.

While there are many instruction books upon this subject, an examination of this one shows that the method of treatment is both novel and interesting, and in every way calculated to rapidly advance the student to a thorough knowledge of the principles of mechanical drawing, orthographic projection and perspective. The feature which at once attracts attention is the extensive use of photographic illustrations of models, which so clearly present the several lessons, as to place this book in a class by itself. It is decidedly the book for beginners, and the student who will study it faithfully, will find progress easy, rapid and thorough, and upon its completion, well prepared to pursue advanced work in such special lines as may seem best. Teachers in mechanical drawing will find the book of great assistance in giving an added interest to class work. It is printed on extra heavy plate paper, with 163 illustrations and eight large plates.

A BRIEF COURSE IN GENERAL PHYSICS, GEORGE A. HOADLEY, A. M., C. E., AMERICAN BOOK CO., BOSTON, 463 pp. $7\frac{1}{2} \times 5$ INCHES, \$1.50.

The aim of the author has been to present the different phases of the subject in a logical manner, with an adequate number of experiments, and yet have the work completed within one academic year. The latter qualification would ordinarily mean that much desirable matter be omitted, but a perusal of the book shows it to be exceptionally comprehensive, and containing experimental work of the most modern type. A feature which will be greatly appreciated in many schools is, that only comparatively simple forms of apparatus are required for the experimental work. Proper attention has also been given to the mechanical principles underlying the subject, thus realizing one of the important advantages derived from its study. An appendix gives additional work, for the benefit of those wishing to meet university entrance examinations, to the 257 experiments given in the regular work.

FIRST LESSONS IN WOOD WORKING, ALFRED G. COMPTON, AMERICAN BOOK CO., BOSTON, 188 pp. 7×5 INCHES, 80 cents.

The author states that the work given in this book is designed for young pupils, say between the ages of eleven and fourteen, but as the larger portion of three chapters is given to making a panel door with mortised joints, the professional wood-worker who might read the book would be rather skeptical of finding many young people of that age who could handle tools well enough to do even a passable job of the kind. There are many other studies in simple wood-working, requiring less material and fully as instructive, which would be preferable to that mentioned, but we can perhaps excuse this in view of the fact that the balance of the book has good, usable work, which is well presented. The illustrations are 84 in number.

HANDY RECEIPTS.

CEMENT FOR GLASS AND METAL.

An excellent cement for uniting glass to metal is made as follows:—Pure gum arabic is soaked in a small quantity of water for 12 hours and will then be of about the consistency of molasses. Calomel (mercurous chloride or subchloride of mercury) is then added in sufficient quantity to make a sticky mass, stirring well to get a thorough mixture. It will harden, after applying, in a few hours so only enough should be made than is required for immediate use.

HARNESS DRESSING.

Myrtle wax, 2 lbs; beeswax, 2 lbs; tallow, 2 lbs; lamp black, 1 oz; castor oil, 2 pints; neatsfoot oil, 1 gal. Mix well by aid of gentle heat, and always mix thoroughly before using. The harness should be well cleaned before applying any kind of dressing. It is best to wash the leather with soap suds, and then dry with a cloth, before using the dressing.

AMMONIA SOAP.

A soap made as follows as a cloth cleaner or grease eradicator is recommended:—Mix together 50 c. c. oleic acid; 25 c. c. ether; 25 c. c. chloroform; 250 c. c. benzine; and 50 c. c. spirit ammonia, in the order given, with occasional shaking. If a white emulsion is preferred, the same or double the quantity of ammonia water, may be substituted for the spirit, the excess of alkali in this case being rather an advantage.

An easy and quick way to get a good bench lathe is to secure twelve or fifteen new subscriptions to AMATEUR WORK.

MACHINE DRAWING. III.

Pulleys, gears, cranks, and other pieces are fastened to shafts by means of keys, the usual form being shown in Fig. 14. Keys, in their several forms, prevent the piece from turning other than with the shaft, and to some extent offer resistance to lateral movement along the shaft. For light pulleys, and pieces carrying only a small load, the *saddle key* shown in Fig. 15, may be used. As it conforms to the shape of the shaft, friction only prevents movement on the shaft. It is much used for temporary fastenings, where cutting the shaft is objectionable. The *flat key* shown at *B*, Fig. 15 is more secure than the other, yet requires but little metal to be removed from the shaft. The *sunk keys* shown at *C*, Fig. 15, is the one used for permanent fastenings, and is much the strongest and most satisfactory of the three. It fits a slot cut in both shaft and piece, has a slight taper so as to hold firmly when in place, yet admitting removal without difficulty, when necessary.

A taper pin, sometimes used in place of a key, is shown in *D* Fig. 15. Its more particular use is that of fastening cranks to their shafts.

A cotter is a tapering bar used for connecting two pieces, in such a way as to resist tension. A simple form is that shown at *A*, Fig. 16; the cotter resists tension while the collar on the rod also resists thrust. The form shown at *B* resists tension only, but has gib ends to prevent movement from place. A divided cotter is shown at *C*; the upper part should be shown with overlapping ends and is called a gib; the other is a plain cotter. An ordinary foundation bolt with iron washer is shown at *D*, Fig. 16, the gib ends keeping the cotter in place. Cotters are often used to connect two rods by means of overlapping straps as shown in Fig. 17. When, owing to vibration or other causes, it becomes necessary to ensure that the cotter will be securely fastened, an arrangement of gib and cotter is used as shown in Fig. 18, the gib having shoulders and the cotter, which passes through the gib, fastened with a screw-bolt.

One view of a knuckle is shown in Fig. 19; these being used to connect rods which, for various reasons, cannot be fitted with a rigid joint. An adjustable joint is shown in Fig. 22, each end of

the long nut being threaded, one end with a right hand thread and the other with a left hand thread. The central portion is without threads and enlarged to clear the ends of the rods. The outside is usually hexagonal, to which wrenches are applied for adjusting.

A flange coupling is shown in Fig. 20, each flange being keyed to the shaft with a sunk key. A hanger for shafting is shown in Fig. 21, one half giving a front view and the other half a cross section view. This is a common method for drafting any piece which is alike on both sides, a considerable saving in time and number of drawings being affected thereby. It must be understood by the reader that the exercises given in this series are but a few of the many forms of devices in use, but they will serve to give a general idea, which the reader can study in greater detail as occasion may require. The studies in Fig. 16 are sectioned and shaded to show the greater clearness given to drawings by such work.

The latest record broken is in the ballooning line, and a message from Berne informs us that a balloon has reached the enormous altitude of almost 11 $\frac{1}{4}$ miles. This is an improvement on the first notable ascent, 120 years ago, when 1, 500 ft. was the height attained. This Swiss balloon, of course, carried no human cargo, but only self-registering instruments. These showed that the greatest cold experienced was 58° below zero. Men have managed to ascend to an altitude of seven miles, but their condition was fraught with great danger. Perhaps in the future some contrivance, in the shape of a closed car, may be invented, which will permit of much loftier ascents; but there seems hardly sufficient inducement to warrant the risk.

Steam Generation, says *Cassier's Magazine*, is the result of several processes which are carried out with a boiler or generator of suitable design. These processes are (1) combustion, which means the combination of the oxygen of the air with the carbon, hydro-carbons, and hydrogen of coal or other fuel at a suitable temperature; (2) transmission of heat; (3) change of the physical state of the water in the boiler, in which is involved the phenomenon of latent heat.

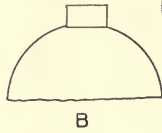
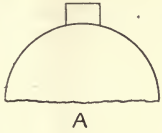

FIG. 15.

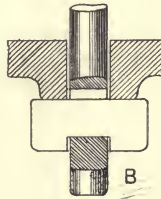
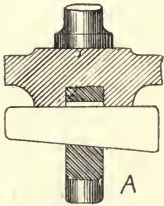
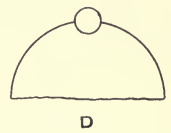
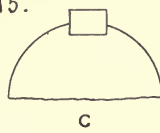

FIG. 16.

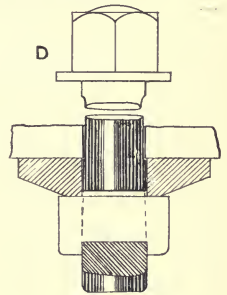
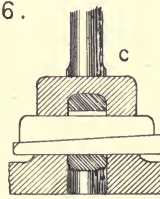

FIG 17

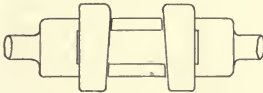

FIG. 18.

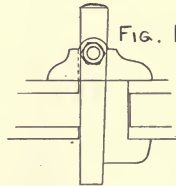

FIG.

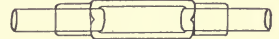

FIG. 19.

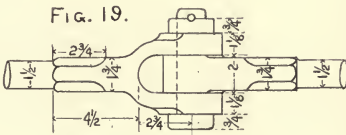

FIG. 20.

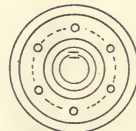
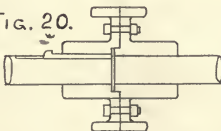
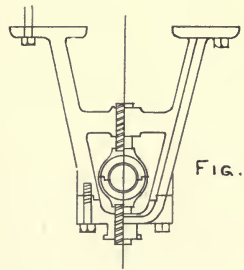

FIG. 21.



AMATEUR WORK

77 WILBY ST., BOSTON

DRAPER PUBLISHING CO., PUBLISHERS.

A Monthly Magazine of the Useful Arts and Sciences. Published on the first of each month for the benefit and instruction of the amateur worker.

Subscription Rates for the United States, Canada and Mexico \$1.00 per year. Single copies of any number in current volume, 10 cents.

TO ADVERTISERS.

New advertisements, or changes, intended for a particular issue, should reach the office on or before the 15th of the previous month.

Entered at the Post-office, Boston, as second-class mail matter Jan. 14, 1902.

FEBRUARY, 1904.

The turning lathe premium announced in the previous issue is quite as successful as we anticipated it would be, and many readers of this magazine will soon be the happy owners of these lathes. Those who have visited our office, and seen the one here on exhibition, have expressed the opinion that they do not see how we can offer such a fine lathe for such a small number of subscriptions. It certainly is a very liberal offer, and we are confident that every reader without a lathe would earnestly wish for one could they but see it. We will make this an easy matter in the following way; for the first one hundred lathes, we will receive subscriptions for one-half the specified number, the balance payable in cash at the rate of fifty cents for each subscription lacking the requisite number. Six subscriptions and three dollars would, under this arrangement, enable a subscriber to obtain the smaller lathe; and seven subscriptions and four dollars, the larger one. The little work required to get this number of subscriptions should make the lathe easily obtained by anyone. Try it.

As many of our readers are interested in electricity, we have arranged for a series of articles on "Electricity by Experiment," the first chapter

to be published in the next issue. Not only will many interesting experiments be given, but complete descriptions of how to make the apparatus necessary to perform them. At the same time, care has been taken to keep the character of the experiments and the necessary apparatus, to as simple lines as the subject will admit. Anyone desiring to thoroughly study this important subject should become a regular reader of this magazine. Those soliciting subscriptions should call attention to this series of articles when talking with those likely to be interested in them.

A new gem, lilac-colored and transparent, has been found in two distinct places in California, the most plentiful deposit being only a short distance from the town of Palo, and within a mile of a well known rubellite mine. Dr. Baskerville gives it the name of Kunzite, in honor of its discoverer, Dr. Kunz, who has described its tint as as sort of "rosy lilac," varying from a very pale tinge when looked at traversely, to a rich amethystine hue when observed lengthwise. When cut and mounted in a certain way, one of these crystals yields a gem of unusual beauty. The discovery is of more than ordinary interest because nothing similar to the new gem has ever been seen by gem experts or jeweller's before. In the course of the tests by Dr. Baskerville, the Kunzite crystals were subjected to the action of ultraviolet light without showing any evidence of fluorescence or phosphorescence, and it was not until it was subjected to the bombardment of X-rays of very high penetration that it became at all fluorescent. On its removal to a dark chamber, it exhibited a persistent white luminosity never before observed in its class of minerals.

A remarkable pearl cluster from Shark's Bay, West Australia, will be exhibited at the St. Louis Exhibition by C. A. Burt. It consists of about 150 pearls in a solid cluster, and measures several inches, and is about $\frac{1}{2}$ inches thick. A cluster known as the Southern Cross, found some years ago at the Lacedped Islands, was sold for close upon \$50,000, and judging from this, the cluster should be worth from \$75,000 to \$100,000.

A SIMPLE BALANCE.

ROBERT GIBSON GRISWOLD.

A pair of good balances is a very valuable acquisition to the amateur's dark room or laboratory, and they are often quite expensive. The one herein described is not very hard to build, is very sensitive, and compares very favorably with those being sold in the market for \$15 to \$20. In fact,

of a hack-saw and file, carefully cut out the beam and finish it as smoothly as possible with a dead smooth file, then crocus cloth and oil. Lay out a centre line passing through the centres of the end edges, and another at right-angles thereto at the centre. Then lay off the three holes for the knife

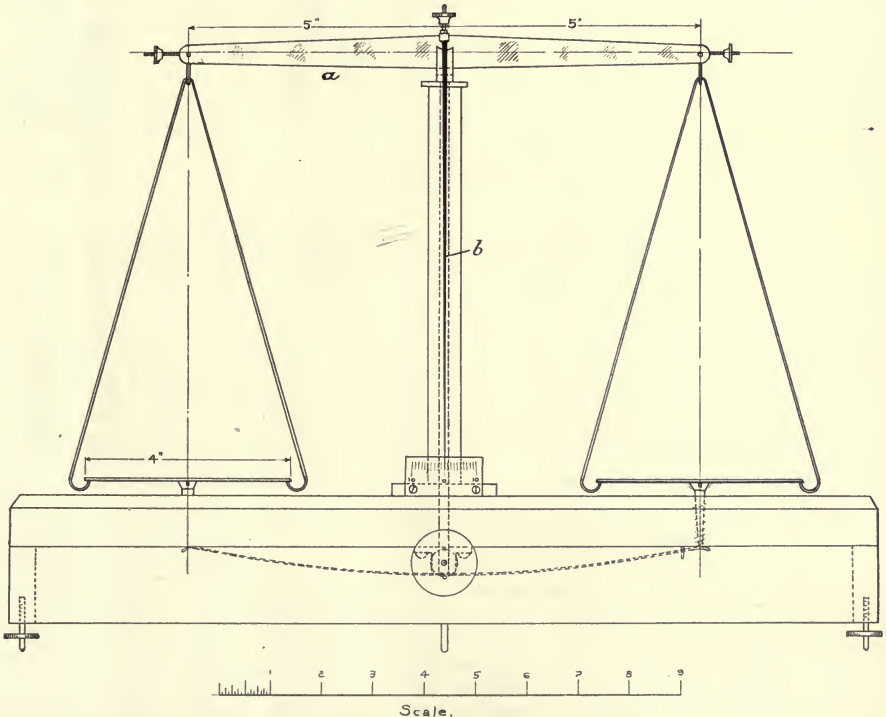

about the only thing in a balance that does cost money is the skill necessary to adjust them, and with ordinary patience, this can readily be done by an amateur so that the balance will render excellent service.

The beam *a* is cut from $\frac{1}{8}$ " sheet brass. Select a piece of sheet brass of the stated thickness, which is very flat and straight. Then lay out the shape of the beam thereon, and with the aid

edges so that the upper edge of the holes at the ends just touch the line and the bottom edge of the centre hole does the same. The holes at the ends are $\frac{1}{8}$ " and the central hole $\frac{1}{8}$ " in diameter. Take great care to drill them parallel.

At each end file a $\frac{1}{8}$ " slot forming a fork as shown in Fig. 2. This is to accommodate the pan hangers. The small adjusting screws at the ends are pieces of $\frac{1}{8}$ " brass wire threaded with a

small die of about 60 threads per inch. One end is flattened and soldered to the back of the beam with a small bit of solder. The nuts are cut from a $\frac{1}{4}$ " brass rod and may be given a knurled edge by pressing on the edge with a mill file while rolling the nut on a hard block, provided no lathe and knurl are at hand. The end knife edges are made of $\frac{1}{16}$ " steel and the middle one of $\frac{3}{8}$ " round steel. Fig. 3 shows the general form of the edges and the end edges may be made by grinding a hollow on opposite sides so that the



Fig. 2.



Fig. 3.



Fig. 4.

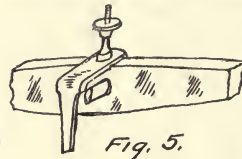

Fig. 5.

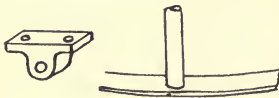

Fig. 7.



upper edge is about a 60° angle. The middle edge is filed down so that the edges on both ends are exactly in line. These knives are annealed before filing to rough shape, then hardened and ground on an oil stone to a keen edge. They must be placed in the beam so that all three edges are exactly in line; if not, slightly bend the beam by pening at the middle until they are so.

From a stout sewing needle make two hooks, as in Fig. 4, the hooks forming a right angle with each other. Anneal the needle first, and bend while still red, then harden by plunging into water. Polish the bearing surfaces with a stick and crushed rotten stone. The semi-circular groove in the end edges will prevent the hook from turning and striking the sides of the beam fork. The pointer or spear *b* may be made of $\frac{1}{16}$ " spring brass wire, or cut from a flat sheet and filed to shape, which really makes the best job. Fig. 5 shows the method of making the top, and the gravity bob screw serves a double purpose in holding it in place. A small groove should be filed in the beam to keep it always in the correct position. The spear must extend far enough beyond the knife edge to allow the supporting fork to clear.

The pans are made of $\frac{1}{8}$ " sheet aluminum, and with bows or hanging wires of either aluminum or German silver, riveted firmly to the pans from underneath as shown. The pans are 4" in diameter. In Fig. 6 is shown the supporting fork for the middle knife edge, and it should be filed out of a piece of tool steel that has been well annealed. Polish the bottom of the V well, that there may be little friction at this point. On the outside, as shown in faint lines, cement small

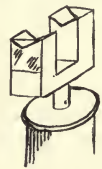

Fig. 6.

pieces of glass to keep the edge from sliding too and fro. The knife must be just a little shorter than the distance between the end plates of glass, and should also be ground to a keen point, as shown in Fig. 3, to reduce the possible friction to a minimum. Mount this fork on a $\frac{3}{8}$ " brass rod long enough to pass through the base as shown.

The column is made of $\frac{5}{8}$ " tubing, and a flat piece soldered to each end, one to form a base and the other the top. Each is drilled to accommodate the rod which must be a very snug fit, but still free. To the base secure a piece of white celluloid, and mark twenty equal dimensions other than that it must be made of some hard wood, either walnut, mahogany or cherry. It is provided with two leveling screws and a stationary pin in the rear. Two ordinary brass wood screws are inserted directly under the middle of the pans to keep them from swinging. The heads should have thin pieces of felt glued to them, and by screwing them in or out, the spear may be made to point exactly to zero when at rest.

Under the base is the lifting mechanism, which is shown in greater detail in Fig. 7. The $\frac{1}{8}$ " rod passing in from the front terminates in a hook, and the latter is provided with a pin set at a $\frac{1}{4}$ " radius, which, by the rotation of the shaft, causes

the rod carrying the beam support to rise and fall. To the bottom of this vertical rod is soldered a long, thin, brass spring which bears against the under side of the base, and keeps the beam from swinging from side to side, and to further secure it, a couple of brass nails may be driven into the base at one end. The outer end of the lifting shaft is provided with a knurled head $1\frac{1}{2}$ " diameter, by means of which the beam is raised. File a very shallow groove in the brass spring directly under the vertical rod, into which the pin may slip and remain, to prevent turning while in use.

Now adjust the balance by means of the end screws until the spear stands at zero. Place any weight on the left pan and balance it exactly by placing small weights and finally sand on the right pan. Then transpose the weights, and if

the pointer still swings to zero at rest the beam is correct. If not, the heavier weight will have been on the short arm, and this must be lengthened. To do this, lay the beam on a smooth piece of iron and lightly tap it with a flat face hammer. This will stretch it lightly. Now return it to the rest and balance again, repeating the above operation until an exact balance is secured upon a transposition of weights.

The sensibility of the balance is effected by the small gravity bob on top; raising it increases the sensibility and lowering it decreases the sensibility. With careful work, and adjustment of the gravity bob, this balance should indicate a tenth of a grain with perfect distinctness under a load of say ten ounces. Polish all the metal forks and give a good coat of lacquer before making final adjustment.

A MECHANIC'S NOTE-BOOK.

"AMATEUR."

In almost anyone's daily reading and experience he comes across many notes and sketches which are worth saving for future reference. These are apt to be taken down on loose sheets of paper, and lost before being needed again. A description of a simple note book and some methods of arranging material so that it will be easily found when wanted, is here given.

Of course, any kind of note book can be used and information, tables, etc., put in as fast as found, but in this way it will be difficult to find any desired article without going through the whole mass. It is therefore desirable to have some kind of loose-leaf, or expansive book, which will allow of any desired arrangement. There are several kinds on the market, but the good ones are rather expensive, and those with a flat binder put through and bent over, are objectionable from the fact that when the book is separated it is necessary to remove the binders, leaving the sheets loose, which is not only troublesome, but after a time the holes in the sheet become so worn that they are useless. The following is the description of a note book made by the writer, which allows easy separation for insertion rearrangement, and is nearly as easy to write in as a bound book.

At almost any stationary stores "Students' note book covers" can be obtained; these are board covers like Fig. 2, with a hinge and a narrow strip along one edge with eyelets to take binders, which are bent over with the paper between. They come in several sizes,

and a pair should be obtained of the size desired for the note book, say, $6'' \times 8''$ or $8'' \times 10''$, the latter being a handy size as it is large enough to accommodate quite a large table or sketch. If these are not obtainable, the cover can be made of an old book cover or a piece of pasteboard covered with cambric pasted on. The narrow part is about $\frac{3}{4}''$ wide and there is about $\frac{1}{4}''$ left between the two for the hinge, the covering being pressed down between them to keep them apart. The inside is then lined with paper.

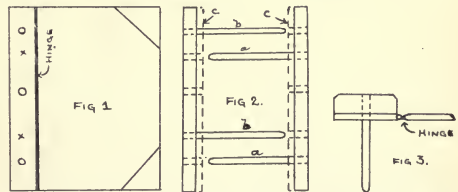

If the cover is purchased, there will be a hole near each end, and perhaps in the middle of the narrow part, two more holes about $\frac{1}{4}''$ diameter should be punched about $\frac{1}{2}''$ from those already there, as shown by the crosses. Two pieces of hard wood about $\frac{1}{4}''$ thick, and the same length and width as the end pieces are procured, and also four pieces of brass rod, $\frac{1}{16}''$ diameter and about $\frac{1}{4}''$ longer than the desired thickness of the book. These should have the ends

smoothly rounded, and are to be fastened into the wood strips as shown in Fig. 2. A good way to do this is to thread the end and screw it into the wood, or it may be carefully driven in and held by friction, or a brass screw.

The hole opposite each pin should be a loose fit to allow the pin to pass in when there are few leaves in the book. The covers are slipped on as shown by the dotted lines *c*, *c*, and the cover is ready for use. The middle hole is to pass a cord through to hold the book together. The best paper for this use is a thin bond, as it bends easier and is thin enough to lay on a drawing and trace through, if desired. It can be obtained at a stationers for from 50 cents to \$1.50 per ream of 500 sheets and can easily be trimmed to suit, but the best way will be to buy a ream and make the book to suit. The sheets are all to be punched with the five holes, and care must be taken to have all punched as near alike as possible, so that the edge of the book will be fairly even. They can be then slipped on to the pins and the book is complete. It will be seen now, that if it is desired to separate the book at any point to insert or remove a leaf, a part will stay on the pins *b b*, and the rest on pins *a a*, and it is readily put together again, and held by a cord passed through the middle hole.

The best way of keeping the material that the writer has been able to find is to divide the book into several different divisions or heads, such as, workshop re-

ceipts, useful formulas, references to articles, etc., personal needs governing the number and kind of classification. Each article as it is put into the book is filed alphabetically in its proper head. As the size of each division increases it will be found helpful to have the leaves tabbed with the letters of the alphabet. These may be made of card about $\frac{1}{4}$ " wide and pasted on the leaf with the letter extending out from the body of the book, thus allowing easy access to any letter. If desired, these alphabets may be purchased of leather all gummed, ready to stick in place, and are much more durable than plain paper ones.

Short formulas, etc., can be copied in directly and preserved intact, clippings may be pasted in, but should be pasted along the inner edge only, to allow the book to open smoothly. Any article which is too long to be copied and cannot be cut out may have its location noted; the publication, date and page; so that it will be easily found. Sketches or diagrams can be drawn out and inked if desired; this is a very good idea, as blue prints can be taken through the thin paper if a copy is desired. As fast as notes are taken the book is taken apart and the page inserted in its proper alphabetical position under its right head.

In the writer's experience of compiling data, references, etc. this method is the one which has been of the greatest use to him, and it is hoped that it will also prove useful to at least some of the readers of AMATEUR WORK.

ELEMENTARY MECHANICS.

PROF. J. A. COOLIDGE, ENGLISH HIGH SCHOOL, CAMBRIDGE, MASS.

I. The Lever.

How can a teamster with a long stick of timber lift one corner of his heavily loaded wagon, so that a wheel can be taken off? How can a freight agent with an iron bar move a freight car weighing 20 tons by simply putting his bar behind one of the wheels and using a very moderate amount of force? How can a carpenter with a hammer pull a nail from a board? These and many other similar questions in mechanics, arising in our daily life, are before us demanding an answer, and we will now set about our task, making our own simple and inexpensive apparatus, that shall, however, give us accurate results. The first principle to receive our consideration is:—

THE LEVER.

For our levers, we need two pieces of wood (maple, or some other hard wood is better) 40" long, 2" wide, and 1" thick. These must be carefully and evenly planed and sandpapered, so that they will balance on a pivot placed under the centre of the board. They should be marked off accurately in inches and half

inches, and then given a coat of shellac. We will now make two pivot blocks on which our levers shall turn. They should be triangular in section, 4" long and 2" wide. A block, or box filled with sand, 4" square, and two pieces of wood 2" x 3" x 5" will complete our wood work.

We suppose everybody has access to a carpenter's bench and tools, for if one does not have them himself, he will find almost any carpenter, if approached wisely, sufficiently interested in his project to be willing to allow the use of his bench and tools and also to give valuable advice. We shall need a set of weights to use in these experiments and the others that will follow. To make these, two ways are suggested. Take an ordinary screw eye or screw hook, twist about it a short piece of wire, insert this in a quarter pound baking powder box (or a smaller one if you can get one) and pour in some melted lead. See Fig. 1. By filling our can to different depths we can get a number of weights of different sizes. These

we will take to some store where we can cut or file off enough until they are of exactly the required weight. Any grocer will give the use of his scales for this purpose. We will make a set consisting of one 4 oz. one

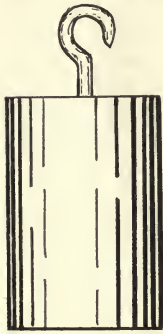

FIG. 1.

8 oz. two 16 oz. two 32 oz. one 48 oz. and one 64 oz., and a convenient box ready for use and storage. The screw hooks can be bought for five cents a dozen. The lead will melt in any iron pan on a kitchen stove. Moulds can also be made by placing two pieces of smoothly planed hard wood of fine grain, boring holes of different sizes centreing on the joint, and held together by a large screw or clamp at each end.

After boring the holes, smooth the surface with graphite powder. The screw eyes are held in position while poring, by putting the screw through thin pieces of wood, and placed across the centre of the hole.

A cheaper set of weights may be made by sewing up some little bags of cloth and filling them with sand so coarse that it will not sift through. Our apparatus may be seen when adjusted, Fig. 2. Let us call the weight at the right, the power, F , the fulcrum or pivot, W , the weight to be lifted, B , the box that raises the lever above the table on which it rests so that the weights P and W may be suspended from the bar by loops of wire or twine, R and R two blocks placed under the ends of the lever to prevent it from turning too far. The distance along the bar from F to P is the power arm and from F to W is the weight arm

EXPERIMENT I.

Support the bar at its centre on F .

- a. Hang a 16 oz. weight $10''$ to the left of F . See if a 16 oz. power $10''$ to right of F will balance.
- b. Hang a 32 oz. weight $5''$ to the left of F . See if a 16 oz. power $10''$ to right of F will balance.
- c. Hang a 64 oz. weight $6''$ to the left of F . See if a 32 oz. power $10''$ to right of F will balance.
- d. Hang a 20 oz. weight $4''$ to the left of F . See if a 4 oz. power $20''$ to right of F will balance.

Try two more cases using other weights and distances. Notice that in cases b, c, d , a small power at a long distance will balance a large weight at a short distance. Also that the power $P \times$ the power arm $P F$ equals the wt. $W \times$ the wt. arm $W F$. This is the law of the lever, discovered by Archimedes, 250 B. C. We have now an explanation of the teamster lifting his wagon. A man weighing 160 lbs, using his weight as

a force on the end of a timber 12 ft. long, if the fulcrum is 10 ft. from the end, exerts a turning force of 10×160 , or 1600. If the wagon rests on the end of the lever 2 ft. from the fulcrum, the weight of the wagon $\times 2$ equals 1600. Therefore the wagon must weigh 800 lbs. With a longer bar and a shorter weight arm, he can lift more.

In all the trials just made, we have rested the bar at its centre. Now we will place the pivot nearer one end and see if the weight of the bar has any effect. Before doing this, let us weigh carefully one of our levers at some store and on the bar mark its weight in ounces.

EXPERIMENT II.

Let us hang a 32 oz. weight, $5''$ from the left end of lever, with the fulcrum $5''$ further to the right. Our bar will balance, perhaps, without any power, i. e., there is so much more of the bar on the right of the fulcrum that a weight of 32 oz. is needed on the left, to have the lever balance. See Fig. III.

According to the law of the lever, $P \times P A$ equals $W \times W A$; but the only power used is the weight of the lever, therefore, $P \times P A$ equals 32×5 . As P is the

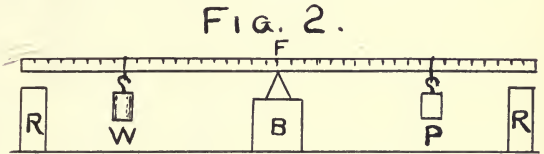

FIG. 2.

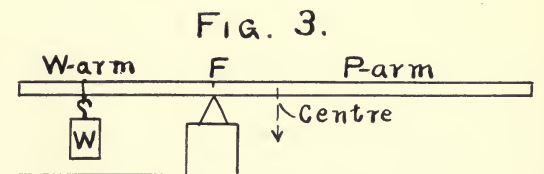

FIG. 3.

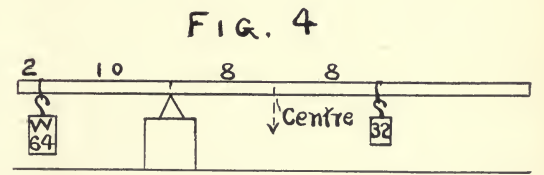

FIG. 4

weight of the lever, its distance should be 10 inches if the lever weighs 1 pound, or less if the lever weighs more than a pound. If the distance is 10 inches we find the place where it acts is at the centre of the lever. If this is so the weight of a lever plays a part in its use, although, unless it is very heavy, a comparatively small part. To test the accuracy of this experiment, let us take the lever that we have not weighed, and arrange it as in Fig. III. When we have made it, lower arm, weight arm, and weight. balance, we

have (P arm Wt A arm, and Wt). As $P \times P A$ equals $W \times W A$, we can find P by solving this equation, or dividing $W \times W A$ by $P A$. But as P is the weight of the lever, we have found its weight. Now we will weigh this lever, and we should find our results correct within one or two ounces.

EXPERIMENT III.

To test the accuracy of our conclusions place our pivot 12 inches from the left end of the lever. See Fig. IV. Hang a 64 oz. weight 10 inches from the pivot and see what force, 16 inches to the right, will balance this weight. Our power now consists of two parts, one the weight of the bar which acts at the centre, and the other, the smaller weight hung 16 inches to the right of the pivot. Our calculation will be; $Wt \times W A$ arm = wt. of lever \times distance of F to centre + $P \times P A$ arm.

If our bar weighs 16 oz. these should be

$$64 \times 10 = (16 \times 8) + 32 \times 16 = 128 + 512$$

$360 \div 5 = 72$. In lever 1 the weight is the pull exerted on the string S and is not really a weight lifted, but become the force in lever 2. This force, then, in lever 2 is 72 oz. As S is 30 in. from F in lever 2, $P \times P A = 72 \times 30 = 2160$. W in lever 2 is equal to the weight of the bar together with the weight W , which we will hang at the centre of the bar 2. $W \times W A$ must equal 2160, and as $W A = 10$, $W = 2160 \div 10$ or 216 oz. If one bar 2 weighs 16 oz. the weight W should be 200 oz. and we must use about all the weights we have made. The questions of the bar moving a freight car, and the hammer drawing a nail cease to be incredible when we see this small force overcoming so large a resistance.

We ought to try two or three more cases of this kind, but with the directions already given, the task is an easy one. Usually in class I, always in class II, the power is small and the weight large. There remains a kind of lever, class III, in which the power is

FIG. 5.

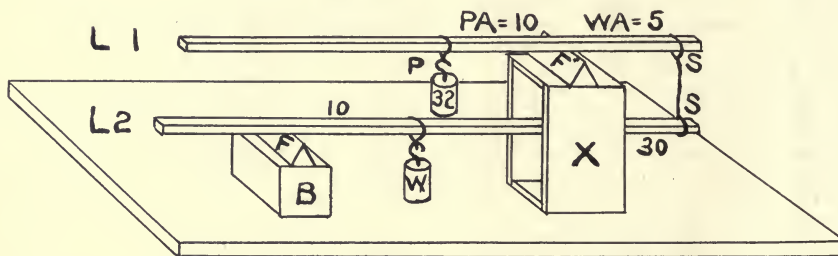

In the experiments just performed, the power is always at, or near one end, the weight is at the other end and the fulcrum or pivot between. The power acts vertically downward. Levers of this kind are called levers of class I. We must now consider class II, where the fulcrum is at the end of the lever, and the power is exerted upward. For experiments of this kind, a spring balance, measuring from 1 to 64 oz. is very desirable, as the balance can measure a force exerted vertically upward. We will, however, arrange two levers so that on one of them the force will be exerted upward with an amount that can be measured.

EXPERIMENT IV.

The lever 1 rests on a box X , whose top and bottom have been removed so that lever 2 can pass through the opening and rest with one end on B . Our only need of lever 1 is to change a downward force at P into an upward force at S . In this way the pull on the string S raises the right end of lever 2 and with it the weight W . To simplify matters let P be hung at the middle of bar 1, and W at the middle of bar 2. We find then in lever 1, that the total force is P + the weight of bar 1, which we will make equal to 36 oz.

As this is to be 10 inches from the pivot, $P \times P A = 36 \times 10 = 360$. Then in lever 1 $W \times W A = 360$, but we have made $W A = 5$ inches; therefore, $W =$

always larger than the weight. The arrangement of a lever of this class is much like that in class II; the pivot is at the end but must hold that end down as the tendency of that end is to fly up, the power is near the pivot and the weight at the other end.

EXPERIMENT V.

Arrange lever 2 as in Fig. 5, only tie the bar down at F by means of a string run through a hole bored in block B . Some weights must be placed on B to keep it down. S and W in Fig. 5 must change places. The calculations will be the same as in case II, only the power arm is short and the weight arm long. Make S 64 oz. and the distance from F 10 inches; if W is 32 inches from F its value must be 20 oz. Make one or two additional trials using your own values. A fishing pole is, perhaps the simplest implement that is a lever of class III.

We must not think that, because we can make a small force lift a large weight, we are gaining at every point. There is no gain without a corresponding loss and what we gain in raising a large weight, we lose in being able to move it only a small distance, or if we move a small weight with a large force, we gain in making a small weight move very fast or of through a long distance. These are the advantages of most machines, and make them well worth studying.

HOW TO BUILD A SAILBOAT.

CARL H. CLARK.

II. Setting Up The Frame.

Fig. 6 shows the method of setting up the foundation for building. It is supported as shown and braced fore and aft and sidewise very strongly, as there may be considerable strain brought to bear upon it. The wedge shaped pieces at the ends are cut out and put on to give further support to the keel. The curve should be carefully cut to fit the mould as nearly as possible at every point. The mould positions should be marked on the foundation for use in bending the keel. It would be possible to build up a foundation of blocks, beveling them off to fit the keel mould and bracing them securely. This method is not as good as the former, but with careful work, and sufficient skill, a good job may be done. In either case, it should be formed that the load water line marked on the mould will be level. This will make it easier to set-up the frame.

and then turned over and the outline of the under side drawn in the same manner with the table dimensions.

The rabbet is now to be cut $1\frac{1}{2}$ " deep, along the line on the bottom, this allows the keel to project $\frac{1}{2}$ " below the $\frac{1}{2}$ " plank. The rabbet may be left square for the present. The stem is a natural crook knee about 2" thick, worked out to the shape of the stem mould and scarfed to the keel. This scarf should be marked on the keel mould and transferred both to the keel and the stem, allowing the scarf to be fitted approximately before setting up. Following the rabbet line there is a rabbet cut in the stem to take the ends of the plank. It is $\frac{1}{2}$ " deep and can be cut only approximately until the stem is in place and the angle of the plank definitely determined.

The sternboard is of $1\frac{1}{2}$ " oak cut to the shape shown in Fig. 5. The rounded upper edge should be left full and trimmed off after the deck beams are in place. The edges also are beveled after it is set up. The two centre board logs are to be gotten out of 2" plank 11" long and 8" deep in the widest part. They should conform to the shape of the mould, so as to fit nicely on the top of the keel after it is bent. The edges must be perfectly square and even, as the joint between them and the keel must be water tight. The top edge must be straight and square as the sheathing of the centreboard box fits against it.

The keel is now to be bent into the form. To do this it will be necessary to thoroughly steam it, preferably by putting into a steam box, but if this is not at hand it can be steamed by wrapping it with cloths and keeping the latter saturated with boiling water for some time until the keel is limber enough to bend to shape easily. The ends, where there is no curve do not, of course need steaming. When it is limber enough to almost bend of its own weight it can be laid into the form and braced into place, being sure that the mould lines on it coincide with those on the foundation. Braces are placed as closely as possible, bearing against the beams overhead. These braces can be cut rather long, and by fixing the top and sliding the lower end along the keel, a wedge action may be obtained. All the braces should be forced down together to avoid straining in any particular place. It will be well to place a piece of board under the lower end of each brace to avoid any tendency to concentrate the pressure and split the keel.

The centreboard slot would best not be cut until after the keel has been bent, unless the builder is a

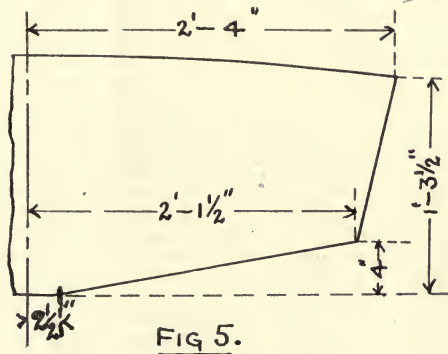

FIG 5.

The keel is formed of a 2" oak plank about 20' long, and 10" wide. The half breadths at each mould point are given in line 6 of the laying off table, except that $1\frac{1}{2}$ " must be added to each one to allow for the back rabbet mentioned above, and shown in Fig. 4. This will make the greatest width 10" on numbers 3, 4 and 5, the others being $4\frac{1}{2}$ ", $5\frac{1}{2}$ " and $5\frac{1}{2}$ " respectively. The width at the sternboard is 5" and where the stem joins the keel it is 4". It should be noted that the positions of the moulds as marked on the keel will not be evenly spaced, as the distance between them is not measured horizontally, but around the keel mould, as the keel is to be finally bent. This spacing can be obtained by measuring from one to the other around the keel mould. The batten is again used to draw the curved lines as before. The keel is trimmed to shape

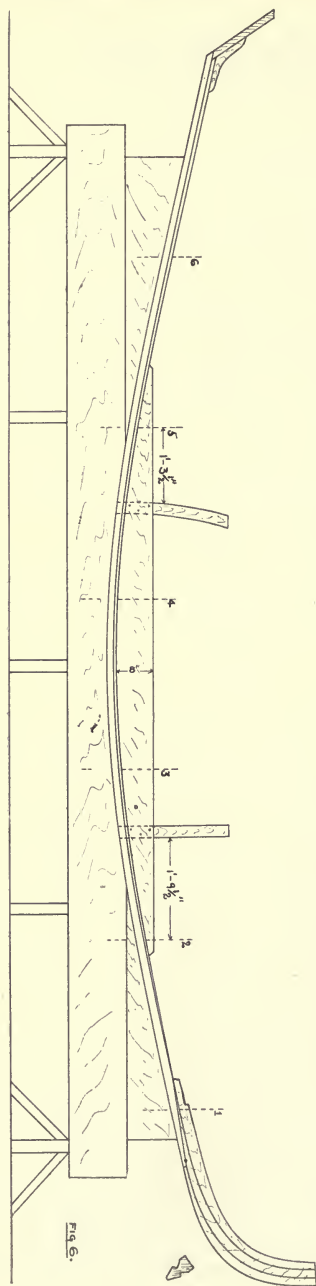

Fig. 6.

very skillful workman, as the removal of the material of the slot will cause a tendency to a sudden bend at the ends of the slot, which may be rather difficult to get out. The keel should be allowed to rest for a day or two until thoroughly dry, before being disturbed. Indeed the braces should never be entirely removed, and if, for any purpose one is taken away it should be replaced as soon as possible. It is a long time before a bent timber entirely loses its tendency to spring back. After the keel is in place the mould should be laid upon it to make sure that it is to the exact shape.

The centreboard slot should be next cut. The dimensions for the length are as shown in Fig. 6 and it is $1\frac{3}{4}$ " wide. It should be perfectly straight and square all through. Holes should be bored along the centre line with a $1\frac{1}{2}$ " auger and the remainder trimmed out. Braces may be removed one at a time while it is being cut. The centreboard logs are next carefully fitted to the top of the keel, one on each side of the slot. This joint, as before stated, is one of the most important in the boat and ought to be very carefully made. The uprights at each end of the box are $1\frac{3}{4}$ " thick, 3" wide and about 27" long.

The forward one stands plumb, and the after one is curved on about a 5 ft. radius from the pin on which the centreboard is hung. As will be seen, these pieces extend down through the keel. They should be put into place and the logs clamped to them and the whole clamped to the keel and carefully fitted into place before any fastening is done. The centreboard logs are to be held in place by long rivets extending down through the keel. These rivets are galvanized iron $\frac{3}{8}$ " diameter, driven from the bottom. The washer on the top of the rivet is set down below the surface by boring down about $\frac{1}{2}$ " with a bit slightly larger than the washer. This is necessary, to not interfere with the next board of the box side. Before boring the holes for the rivets, the pieces should be taken down and all surfaces given a coat of thick lead. A thread of cotton, saturated in lead is now placed between the logs and each vertical piece, and a long thread is also laid along between the logs and the keel, quite close to the inside edge of the log, so as to be inside of the line of the fastenings. The whole may then be clamped up again into place, being sure that the centreboard uprights are back to the extreme ends of the slot and that everything is in its former place. Holes may now be bored for the rivets, and each rivet should be driven as fast as bored for, to avoid any chance of any parts slipping. To get these logs into place the braces will need to be removed, but they may be replaced, resting on the logs themselves, and thus aid in keeping them in position.

When the logs have been fastened into place the vertical pieces may each have three short rivets about $\frac{3}{8}$ " diameter driven through them and the logs. It will be seen that this makes a very strong back-bone for the boat and tends to keep her in shape. The stem is now to be fitted on the scarf at the forward end of the keel. It is so fitted that when in place it

and the keel will follow the mould. The scarf, or diagonal joint, should be about 15" long, and as good a fit as is possible to get. The keel should be tapered down to about $\frac{3}{4}$ " thick at the forward edge. They are fastened together with $\frac{1}{4}$ " rivets, about four being used. The after two can be left until later if the foundation interferes with driving them now. The stem must be exactly in line with the two centerboard uprights, and also plumb. The after end of the stem is jogged down to allow the maststep to fit over it. The rivet through this part must, in any case, be left until the step is in place.

The sternboard, Fig. 5 is $1\frac{1}{4}$ " thick, and is cut to those dimensions. The stern knee is 2" thick, each arm being 9" long. It should be natural growth if possible. The angle is obtained from the keel mould or from the original draft on the floor. Where the sternboard fits on to the keel, it is cut down $\frac{1}{4}$ " thus allowing the edge of the sternboard to lie even with the underside of the projecting back rabbet and allows

the plank to fit on both the rabbet surface and the sternboard, as shown in Fig. 6. The under edge of the sternboard is beveled to fit the jog thus made in the keel. The centerline should be left on the sternboard to use in setting up. The sternboard and the knee should be clamped in place and adjusted until the centerline on the sternboard is in line with the stem and centreboard uprights already set up. The sternboard must also be square with the fore and aft line of the keel. These adjustments will be made easy by stretching a line from the centre of the sternboard to the centre of the stem. A sliding line carrying a plumb bob will then tell whether the parts are in their correct positions.

When the sternboard is adjusted, it and the knee may be fastened in place with galvanized screws. It will be found that a little soap or lead on the threads of the screw will make it drive much more easily. The whole should now be painted to prevent checking during the time the boat is being built.

PRINTING FOR BEGINNERS.

FREDERICK A. DRAPER.

IV. Composition.

We have now reached that part of the work in which use will be made of all the materials and furnishings previously described. Other necessary adjuncts will be considered when treating of the special work occasioning their use. With a case of type inclined at a suitable angle on a stand before the compositor, the composing stick, fitted with composing rule, held in the left hand as shown in the illustration, the type is gathered with the right hand from their several boxes and placed in the composing stick. This may seem merely a matter of learning the location of the boxes, but experience will show that much enters into it, not noticeable by the casual observer. The beginner should make every effort to follow the methods which long experience have shown to be necessary when quickness and accuracy are to be acquired without undue fatigue to the limbs and body.

One important matter is that of the attitude assumed, a correct one requiring the front of the case, (lower case if a pair) to be level with the elbow, and a platform should be used by short people to secure the correct height. While not keeping the body rigid, excessive motion is to be avoided as tending to tire the worker. The eye should precede the movements of the hands about the case, the types to be taken being observed with special reference to having the hand secure each one with a single attempt, and not have to make several trials before succeeding. It will

be found easiest to do this if the forefinger and thumb are held nearly vertical, and the type taken up by the top ends, the eye having previously located the type to be taken. While carrying to the stick, the fingers turn the type, when necessary, so that the correct end shall be uppermost, and the "nick" on the upper or open side of the stick.

The beginning of a line is at the end of the stick nearest the wrist or adjustable end, and if part of a paragraph, the first line is indented an em quad. In book-work an indention of one and one-half or two em quads is sometimes given, according to the length of the line, and whether widely leaded or not. Immediately after securing one type, the eye is directed to the box for the next one, as, to become a rapid compositor, every movement of eye and hand must be that which will do the most work with the least exertion, and in the shortest time. When the foot of the type has been placed in contact with the one previously placed, release the hold of the fingers, allowing the type to drop into place with a slight "click." In the smaller sizes of type, the end of the left thumb is lightly pressed against the type, and gently lowers it into the stick. Before each word put a "thick" or 3 em space. With very "extended" advertising type, an em quad is often used for spacing. When a line is about completed, observe the words which follow, and select the word or syllable with which to

begin the next line. It will frequently happen that the last word or syllable does not exactly fill the line, being a trifle short or over the needed length.

In such a case the thick spaces are replaced with en quads or middling spaces as the case may be. Such changes in the spacing are made, where possible, between words which do not end in the same vertical line with those in the line above; i. e., the aim in spacing should be much the same as with shingling a roof, to "break joints." This idea can be followed only to a limited extent, however, and is qualified by another equally important one of avoiding the division of words and use of the hyphen, wherever possible to space out the line without using too wide or too thin spacing. In setting very narrow measure, words may occur in such order that no division in the end word is possible, and to put this word on the following line would require objectionably wide spacing in those remaining. In such a case "thin" spaces are put between the letters of one or more words to lengthen them and thus reduce the spacing between words to correct space.

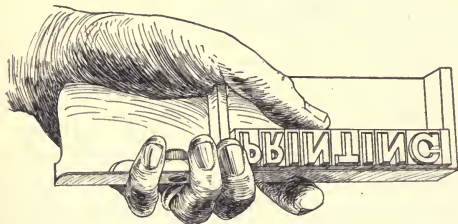

The aim in spacing is to have all lines of exactly uniform length, and much care must be used to secure this, otherwise, the type cannot be firmly locked up in the chase. A "pied" form will take far greater time to make right than will be required to secure correct spacing. It frequently happens that in setting a line, the type will incline a little to one side, thus preventing the final spacing. This is avoided as much as possible by the pressure of the left thumb, but may be entirely removed by lifting the end of the line towards which the types lean, putting in the last space necessary to justify the line, and then pressing the type down into the stick.

The following punctuation marks are usually cast on a thin body, and should each have a thin space between it and the preceding word: — ; ! ? . For the quotation, commas are turned (") the opposite way from that when used regular; two apostrophes (") being used at the end of the quotation. Parentheses () and brackets [] are not separated by spaces from the words they enclose, the same character answering

for both ends by turning one. Place a thick space after the comma.

As composition proceeds, it is desirable to glance along the line, before finally spacing out, to see if the correct letters have been obtained. The experienced compositor does this with the faces of the type upside down, and to the beginner this will be rather confusing, but practice will soon make it easy to do this. Corrections are more easily made if the line has not been spaced, and require much less time and trouble than when made in the galley or form. A "clean proof" should be the aim of every compositor; one full of errors indicates either carelessness in setting up, or in the previous distribution, and is quite likely to share in both these faults. The copy is usually read when picking up the spaces, close observation not being necessary to secure them. The varying thicknesses of letters will frequently help to detect a wrong letter which has been dropped into a different box from that to which it belongs.

Some job fonts contain two styles of the same letter, as here illustrated, *s* and *ſ*, the custom being to use that of eccentric shape only at the ending of a word or line. The words "*ſ*" and "*ſhe*" are also included in some job fonts, their use being regulated by the make up of the surrounding type. Upon the completion of one line, the next is begun after placing a lead, if single leaded, or two leads if double leaded, against the line of type.

LIGHT.

When we speak of an instantaneous exposure, we think we have given something very short. And it is very difficult to realize that our conception of time, according to human standards, may be very far away from what actually takes place. Now, light is estimated in round figures to travel at 190,000 miles per second, and if we estimate the length of the beam that is admitted by our shutter when making a snapshot, we shall get some idea of the enormous possibilities of energy expended in producing the image. For instance, we set our shutter for the 1-20th of a second; that means that a stream of light 9,500 miles long has entered our lens and impinged on the plate, and even for 1-1000th of a second exposure means a stream 190 miles long to work with; or, again, if we have occasion to give five minutes exposure, the light that enters the camera last had not left the sun's surface when we began the exposure.

Photographic News.

Prof. Himstedt, of Freiburg, claims to have made an interesting discovery respecting radium, which seems to show that its existence is far more widespread than heretofore supposed. His experiments are asserted to prove that all products of water and petroleum sources yield a heavy specific gas, closely resembling, and probably identical with the emanation of radium.

THERMIT, THE NEW COMPOUND.

A. FREDERICK COLLINS.

As wonderful in its production of high temperature as liquid air is in its cold producing properties, ranks thermit, the latest invention. This marvellous new compound, to which its inventor, Dr. Hans Goldschmidt, of Essen, Germany, has given the name "Thermit," is made by combining in the proper proportions two elements most frequently occurring on the earth's surface, namely oxygen, in the form of oxides, and aluminum, the metal found in common clay. When these two substances are combined and then ignited, an enormously high temperature, equal to the intense heat of the electric arc light, is instantly produced.

The exact method of making the compound, the simplest way of obtaining the highest caloric value, and the most practicable manner of utilizing the resultant energy created by this process of combustion, have opened a new field of unlimited application, and thus another science is brought into the realm of those termed exact. While the reducing properties of aluminum were discovered at least fifty years ago, the scientific investigators who studied these phenomena overlooked entirely its most essential characteristic. It remained for Dr. Goldschmidt to point and invent a thermit mixture which, when once ignited in a single place, continued its self-combustion throughout its whole mass without any external source of heat. Thus a crucible filled with a seething mass of thermit hot enough for the production of artificial diamonds or the welding of a crank-shank can be held in the hands with impunity, and many other equally interesting and useful experiments may be performed utilizing a temperature diametrically opposite to that of liquid air and in every way as spectacular.

But, unlike liquid air, the commercial value of thermit has already been proven beyond peradventure of a doubt. Its application in the production of pure metals and the faculty with which gigantic pieces of metal are welded together are in evidence in many cities throughout continental Europe.

The thermit compound is a grayish black powder, very like coarse gunpowder in appearance. When it is desired to obtain molten iron either in its pure state, for the arts, or for welding purposes, the aluminum powder and ferro-oxide, or iron rust, are placed in a crucible made of magnesia or other suitable material having high heat resisting qualities. Graphite or clay crucibles will not answer the purpose, for the heat is so intense that under its influence they commence to bulge until their distortion causes them to crack.

The thermit is ignited by putting in a small pinch of peroxide of barium, and a fuse is led to this and ignited. A reaction takes place almost immediately, and the solid oxygen contained in the iron oxide combines with the aluminum, forming an aluminum oxide, while the iron contained in the oxide of iron runs to the bottom of the crucible, in virtue of being heavier than the aluminum slag separated from it. The reaction producing this remarkable result takes place in less than one minute, without regard to the quantity of thermit used. The result is an enormous heat, developed with safety, while in other and older experiments of external combustion there have been violent and explosive effects, and therefore only the smallest quantities could be tested. The chemical reaction provides a rapid evolution of heat, which when started from a given point, raises the next nearest portion of the mixture to a temperature sufficiently high to cause another reaction, and this mode of heat propagation continues until finally the entire mixture is ignited.

To find a method for the initial ignition of the thermit was in itself no easy task, and while barium peroxide is now used for the purpose of ignition, a long line of experiments were made before it was definitely ascertained that it offered the best medium that could be found. Second only in its usefulness to the production of pure metals, but capable of a more spectacular demonstration, is the thermit welding process. As a method for welding, thermit begins where the blacksmith's forge ends.

It is not intended to use the new process for welding small pieces of iron or steel, but where broken pieces of metal of great size are to be repaired, especially *in situ*, it fulfils a place unsupplied by any other method known. Every up to date road may quickly and cheaply have its rails welded together so that a smooth surface may be obtained. It is therefore readily seen what a useful compound it is.

The Mineral Collector.

A new gasoline motor has appeared with a mechanically operated valve, serving for both admission and exhaust. It is worked by the aid of a sliding sleeve, which surrounds the valve, and a peculiar-shaped cam giving two degrees of lift to the valve. Though the means may be new, the result is not, as a combined inlet and exhaust valve has long been a feature of some horizontal motors.

JUNIOR DEPARTMENT

For the Instruction and Information of Younger Readers.

BOOT BLACKING STAND

FRANCIS L. BAIN.

When making any article of furniture it is advisable to first, plane and finish to the proper size, all the smaller and narrower pieces of wood when possible, then finish up the large and wider stock. If this method is adopted the wide stock (such as table tops, box covers, etc.) has very few opportunities to become warped or checked while lying around waiting to be used after it has once been planed to its proper size.

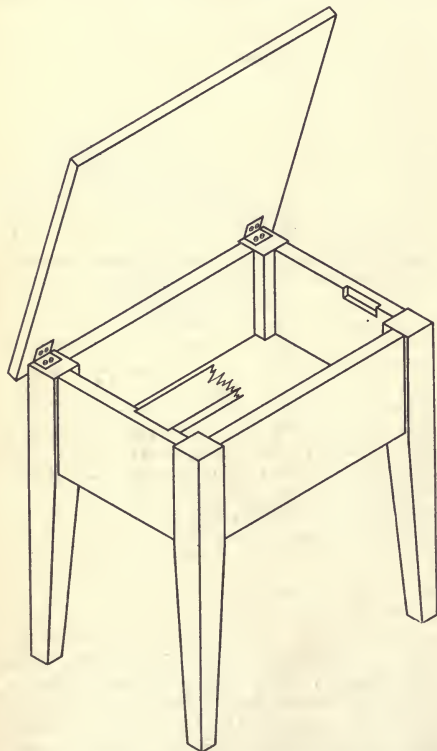

For this reason the legs of the boot-blackening stand will be considered first of all, then the rails, and lastly the bottom and cover. Any kind of stock may be used for this stand, but pine or whitewood represent the

usual choice. The four legs are to be cut from a piece of $1\frac{3}{4}$ " or 2" plank, and they should be planed and finished very accurately to the following dimensions, length 15", width $1\frac{1}{2}$ ", thickness $1\frac{1}{4}$ ". After planing, number the first two adjoining sides on each piece (in the order in which they were planed) with small figures 1 and 2 and across these two sides on each piece a line is to be squared $5\frac{1}{2}$ " from one end, and the surfaces are to be tapered with the plane from this line to the opposite end until the latter (which we will now call the bottom of the leg) is $\frac{7}{8}$ " square. When the stand is put together, the two tapered sides face the inner part, while the two straight sides face the outer, or exposed part. A centre line for the dowel holes should now be drawn on the upper end of side No. 1, $\frac{3}{4}$ " from and parallel with the adjoining straight side, and commencing at the top of the leg, the following measurements should be marked off, $\frac{3}{8}$ ", $1\frac{1}{4}$ ", $1\frac{1}{2}$ ". Taking each of these points as a centre, bore a $\frac{3}{8}$ " hole $\frac{3}{4}$ " deep. Repeat this process on the No. 1 and No. 2 sides of each leg, and place them aside until the rails are made.

The rails should be made from $\frac{7}{8}$ " or 1" stock, the two long rails finishing 11" long, $4\frac{1}{2}$ " wide, $\frac{3}{4}$ " thick, and the two short rails finishing 7" long, $4\frac{1}{2}$ " wide, and $\frac{3}{4}$ " thick. A line should now be drawn on both sides of each piece, which will be just midway between and parallel with the two broad sides of the rail. Commencing at either edge of the rail, mark off the following measurements, and as before bore a $\frac{3}{8}$ " hole $\frac{3}{4}$ " deep, $\frac{7}{8}$ ", $1\frac{1}{2}$ " $1\frac{1}{2}$ ". Then cut off 24 pieces of $\frac{3}{8}$ " dowel, each $1\frac{3}{8}$ " long, and having put some liquid glue in the holes in the end of each rail, drive these dowels in as far as they will go; then put some glue into the holes in two of the legs and join them by fitting in place one of the long rails. Repeat this process with the other long rail and the remaining legs, and place each set in a cabinet makers' clamp, screwing it up firmly in order to draw the legs and rail securely together. After the glue has hardened or "set" remove from the clamp, and finish setting up the frame by gluing in place this short or end rail. Apply the clamps properly on each side and allow the frame to set for eight or 10 hours.

The bottom, which is to be made next, should finish up $12\frac{1}{2}$ " long, $8\frac{1}{2}$ " wide and $\frac{1}{2}$ " thick, and a little square corner is to be cut out of each corner of the legs. The size of the corner to be cut out is $\frac{3}{8}$ " square. The foot rest for the stand consists of two parts, the cast iron "shoe rest" (to be obtained at any shoe finding supply house and at many hardware stores) and the wooden base or support, which is next to be

made. The finished size of this base is $12\frac{1}{2}$ " long, 2" wide and $\frac{1}{2}$ " thick, and the cast iron "shoe rest" is to be attached to this piece by means of $\frac{5}{8}$ " wood screws. The top is the last piece to be made, and for this purpose a piece of stock must be selected that is free from any warp or check of any kind. This piece is to finish up $15\frac{1}{2}$ " long, $11\frac{1}{2}$ " wide, and $\frac{3}{4}$ " thick, and in order to give a little better finished effect, the edge can be "quarter rounded" with a plane.

After taking the frame from the clamps, it is to be sandpapered thoroughly inside, the bottom then being placed in position, with the under side flush with the bottom of the rails all around. Then drive two $1\frac{1}{2}$ " steel wire brads through the lower part of each rail into the edge of the bottom in order to hold the latter in place. The slots or receptacles must now be cut in the inside of the ends, or short rails, as shown in the illustration. This slot is 2" long, $\frac{1}{4}$ " deep, and $\frac{1}{2}$ " wide, and it starts 1" from the inside face of the leg.

The figures given for the size of the top show an allowance of $\frac{1}{2}$ " for an overlapping edge all around, so before marking out the location of the hinges, place the cover on the frame, making sure that the proper margin extends over the outside of the legs all around, then with a pencil, mark around the tops of the legs on the under side of the cover. This will determine the distance from the edge at which the hinges should be placed. The hinges should be attached first to the cover, and afterwards the cover should be attached to the tops of the legs as shown clearly in the illustration. The final work is a thorough sandpapering, first with No. 1, then with No. 0 sandpaper. When not in use, the foot-rest may be removed from the slots and placed in the bottom of the box. The finish may be as desired by the maker.

II. A MODEL STEAMBOAT.

CARL H. CLARK.

The Turbine described in the January number will serve very nicely to propel the steamer. Its position in the boat should be about on section No. 3. A small seating or foundation should be built for it to rest upon. To hold it in position small brass angle lugs are used. These are made by bending a strip of brass at a right angle and drilling a $\frac{1}{8}$ " hole in either leg. One of these may be slipped over each of the two lower bolts before inserting them, and another is put on under the nut on the other end. The other four holes may then be used to fasten the turbine in place.

The shaft hole should be bored $\frac{1}{4}$ " diameter and about $1\frac{1}{2}$ " above the bottom of the keel. It runs horizontally and the seating is built up until the driving shaft is in the same line as the hole. For the shaft, a piece of 3-16" steel rod is used, and is connected to the turbine shaft by a sleeve coupling. The after end of the shaft is filed down square for a length

of about $\frac{5}{8}$ ". The last $\frac{1}{2}$ " is again filed round, and a thread cut, which allows the propeller to put on the square part and a nut to be screwed up against it to keep it in place.

Some sort of stuffing box must be provided at the stern to prevent water running in around the shaft; all that is necessary, being an annular space filled only with packing and held in place. The propeller should be cast and filed up bright. It should be about $2\frac{1}{2}$ " in diameter. The shape and proportions can best be gotten by seeing either a large propeller or some picture of one. The hole in the hub is worked out square to fit end of the shaft and a nut provided to hold it in place. The shaft is inserted from the inside and the propeller is put on. Connection is then made with the turbine. If necessary a bearing may be provided at about the middle of the length of the shaft to prevent its sagging. The exhaust pipe is $\frac{1}{2}$ " diameter and is let up into the stack. The steam pipe from the boiler will be described in connection with the boiler in the next issue.

TOOLS AND THEIR USES.

COLD CHISELS are used for cutting metal. The more commonly used shapes are here illustrated. The *Flat* is used for wide cuts of no great depth. The *Cape* is used for narrow cuts, and in the hands of a skilled workman such accurate work as keyways in



FLAT, CAPE AND ROUND NOSE COLD CHISELS.

shafting can be done with this tool, a file being used for finishing. The *Round Nose* is used in corners, and where its shape makes it more desirable than the two previously mentioned. The chisel is held in the left hand, at the angle best suited to the cut, and given forcible blows with a machinist's hammer, the latter being made of hardened steel to prevent the face from becoming indented. Considerable practice is necessary before the worker can do efficient work with a cold chisel, and yet avoid mis-strokes with resulting damage to the knuckle of the forefinger.

COMPASSES, or as they are now more commonly termed *DIVIDERS*, are used to lay off circles, angles

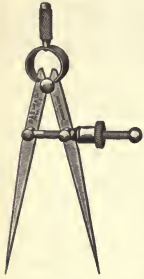

and arcs;] to take measurements, and lay off the same on drawings or work. Also used as a "Scriber" to take of the line of a surface on work, one point following the line of the surface and the other marking the same on the work. The knurled handle projecting above the bow is of great assistance when striking circles, arcs, etc., giving ease of movement and an unobstructed view of the work. For large circles, arcs, etc., *Trammel*

Points on a long beam are used. Crude points for such work can be made by putting pointed wire nails through a strip of thin wood, these serving where no great accuracy is required.

COTTERS are used for holding wheels, pulleys, and other parts of mechanism upon a shaft or similar bearing where a nut or other part has a tendency to work apart. Pins in moving joints are retained in position by cotters at the ends, these uses requiring a split cotter. In piston rods for pumps and engines, they are solid and serve to keep the parts of a bearing or joint in position.

COMPASS SAW, See *Saws*.

COUNTER-SINKS, are used in machines or bit brace for giving a V shape to the outer end of a hole in metal or wood to receive the head of a screw. The *Snail* countersink is used in wood; the *Rose* may be



used in either wood or metal, but for metal work that shaped similar to a diamond drill is preferable. When used in a machine the shanks are straight, and as each shape is made with shanks for either bit-brace or machine, when ordering by mail the method of use should be specified. A combination drill and countersink is a very handy tool when numerous holes for screws are to be made, the hole ready for the screw being made without being obliged to change tools.

CORRESPONDENCE.

No. 70. PHILADELPHIA, PA. Jan. 18, 1904.

I would like to know if you could give the approximate cost of building the sailboat described by Carl H. Clark in the Jan. '04, issue. Also, if a gasoline engine could be placed in the boat, as an auxiliary, without very great change in the boat.

G. G. M.

The cost of materials will vary with the locality; between \$30 and \$40 for the lumber, exclusive of spars. Metal work, about \$10. Sails and rigging \$15 to \$25 according to quality.

A small engine could be installed by cutting away a piece of the deadwood aft, using a balanced rudder, and making water-tight around the shaft where it passes through the keel. The engine would have to be placed in the cabin, or extreme forward part of the standing room.

No. 71. SCHENECTADY, N. Y., Jan. 31, '04.

I would like to know if it is possible to obtain a set of castings for the model steam turbine described in the January number?

J. J.

No castings for this turbine are obtainable in this country, the description being of one made in England. Should a sufficient number of our readers make requests for these castings, they will be offered as a premium.

No. 72. BRIDGEPORT, CONN., Jan 30, '04.

I wish to know if there is any storage battery which will supply current to light six or seven incandescent lights in a satisfactory manner. If so, please tell me where to get them, and the chemicals for charging?

H. F. P.

Your inquiry does not state the size and voltage of the lamps you desire to use. If miniature lamps of 3 or 4 volts are intended, storage batteries are to be had which will do this nicely, of any large dealer in electrical supplies, but the expense for same will be considerable. They will also have to be charged by current from a dynamo, unless another set of cells of another type are obtained for charging, the latter being a rather unsatisfactory way. The Pullen cell manufactured by the Pullen Electric Co., Chestnut St. Philadelphia, Pa., is a cell which may be charged by chemicals, and recharged, when exhausted, in the same way. Twelve to fourteen of these cells would be required for the work above mentioned.

No. 73. PROVIDENCE, R. I. Jan. 30, '04.

Will you kindly inform me what the electrical resistance is of No. 23 guage German Silver wire per foot. Will you please tell me of some firms who make wood turning lathes?

P. H. F.

German silver wire varies considerably in the proportions of its constituents, and consequently the resistance would vary from the same cause. The resistance for 1000 feet, standard quality would be approximately 271.6 ohms. If great accuracy is required for some electrical instrument, the resistance should be obtained by testing with suitable instruments. These can be found at most electric light stations, and those in charge will usually render services of this kind if approached in a suitable manner.

Turning lathes are advertised in our advertising columns by several firms who will send catalogues upon request.

AMATEUR WORK

A MONTHLY MAGAZINE OF THE USEFUL ARTS AND SCIENCES

Vol. III. No. 5.

BOSTON, MARCH, 1904.

One Dollar a Year.

A HOT AIR ENGINE.

W. C. HOUGHTON.

It is the purpose of this article to describe a small caloric or hot-air engine, which may be used to drive a dynamo, small lathe, sewing ma-

eral principles upon which they operate, may be in order. A hot-air engine is much less efficient as a producer of power than a gas engine, and must be several times larger to produce the same amount of power. It will compare fairly well with a small steam engine in power pro-

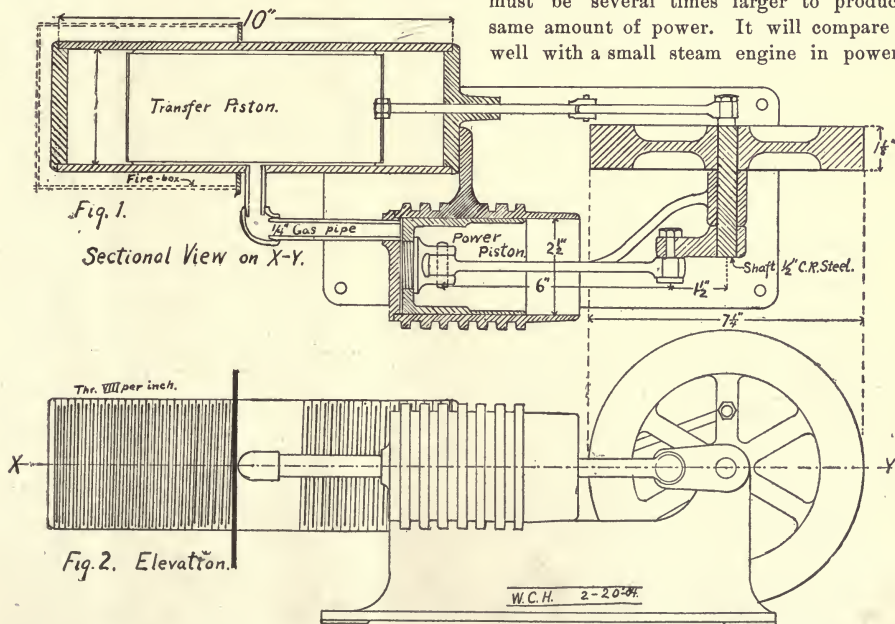

chine, or for any similar purpose not requiring more than one-eighth horsepower. As such engines are not in very common use a few words as to their efficiency, their limitations, and the gen-

duced for a given amount of fuel, but has the advantage of great simplicity and few moving parts. There are no valves, ignition devices, batteries, etc., and no boiler, gauges, pumps, etc., to look

after, and nothing which could possibly cause danger. Such an engine is not, however, adapted to any use requiring great power, or absolute steadiness under variations of load.

It is well known that all substances expand more or less when heated, and contract again when cooled. Air can be expanded to many times its original volume if slightly heated. This fact is made useful in the caloric engine. A small quantity of air, confined in an iron cylinder, is quickly heated, and as it expands is made to push a piston in a connected cylinder. The same air is then cooled, and allows the piston to return, the process being then repeated. This alternate heating and cooling may be accomplished 100 to 150 times per minute, giving as many revolutions of the engine. The way in which this is done may be understood by reference to Fig. 1. The larger cylinder, shown in section at the top, is for heating and cooling the air. All but the middle portion of this cylinder is deeply threaded to give greater radiating and heat absorbing surface. The left hand end is enclosed in a fire-box (not shown) and a suitable burner placed beneath. A gas, oil, or alcohol burner may be used. The right hand end is for cooling, and may be provided with a small fan-wheel driven by the engine to increase the air circulation, and thus cool the air inside more quickly. In the drawing the loose fitting transfer piston operated by a connecting rod from a crank-pin on the fly-wheel, is about at the middle of its stroke to the right. This will displace the air from that end, forcing it to the hot, left hand end of the cylinder. As it expands it pushes its way through the pipe leading to the power cylinder and drives the piston outward. At the end of the out stroke, the transfer piston will have moved so as to send most of the air to the right hand end of the cylinder, where it cools and allows the piston to return. The transfer crank is set 90° ahead of the power crank in order to give time for heating and cooling.

The construction of the engine will now be taken up. The bed-plate, power cylinder and bearing pedestal are cast in one piece, with the cylinder cored straight through for convenience in machining. The cylinder has a bracket cast on the back for attaching the heating cylinder. The construction might be somewhat easier if the cyl-

inder were made of tubing, but cast iron is the only really suitable material for such parts. First, file or plane off the feet on bottom of bed plate so that it will stand firm. Then bolt casting to tool carriage of an engine lathe and bore out cylinder with a boring-bar and fly cutter. The last cut should finish as smooth as possible to a diameter of $2\frac{1}{2}$ ". The ends of cylinder should also be trued up by setting the cutter out and grinding it so that it will cut on both sides. Next locate centre of bearing on a level with centre of cylinder, and drill to $3\frac{1}{4}$ " diameter, and ream to $\frac{1}{2}$ ". Face off ends of bearings to lengths of $1\frac{1}{2}$ " with a counterbore in lathe or drill press. To finish cylinder, make a lead lap, by casting a cylinder of lead about 4" long, and $2\frac{5}{8}$ " diameter around and near one end of a piece of round iron or steel about 12" in length and provided with suitable centres. Turn lap down to a trifle less than $2\frac{1}{2}$ " diameter. Put some fine emery powder on a board, or better, a flat piece of iron. Smear lap with oil and roll in the emery, pressing hard enough to embed emery in the lead. Slip cylinder on the lap, put lap in the lathe, and grind inside of cylinder smooth and true, using the highest speed of lathe, and oiling the lap often enough to keep from running dry. This will produce a cylinder that is truly round and highly polished. If the piston be finished in a similar way and made a good fit, there will be no need of packing rings to keep piston air-tight. The cylinder head is turned off with a shoulder making a drive fit with end of cylinder. The hole is drilled and tapped with a $\frac{1}{4}$ " pipe tap. Head may be threaded and screwed into cylinder if desired. If not screwed in, it should be secured by four pins driven into holes drilled through cylinder walls into head. In either case the joint should be made tight with red lead.

The piston should be cast with a 1" hole cored through the back end. Hold in a chuck by this end and bore out inside enough to clean up. Also face up bottom around hole for wrist-pin fork to screw against. Reverse piston and drive on a piece of iron held in chuck and turned to fit. Turn off outside to $2\frac{1}{2}$ " diameter, face off end, bore and thread hole $1\frac{1}{4}$ " diameter by 20 threads. The outside of cylinder should be finished very smooth and true with a dead smooth file and emery cloth. It may be left a trifle tight

fit for the cylinder and the two ground together with flour emery and oil. The wrist-pin fork, which should be a brass casting, may be held in a four-jaw chuck, the end faced off and shoulder turned down and threaded to fit hole in piston. Also drill a hole in end, taking care not to go through, and tap out $\frac{1}{4}$ " x 20 threads. Then take out of chuck and screw to an angle-plate, centering by turned base and height of boss, and drill for $\frac{5}{16}$ " wrist pin. The wrist pin may be made of cold rolled steel cut off to the right length, and secured by drilling and pinning through one boss after connecting rod is in place. The sides of fork may be faced off in lathe by mounting on back of face plate, but in same position as for drilling wrist-pin hole. The connecting rod should be a brass or bronze casting, but it may be made of bar steel $\frac{3}{8}$ " x $\frac{5}{8}$ ". Lay out centres in bosses at each end 6" apart. Drill with No. 10 drill and tap $\frac{1}{4}$ " x 20 thread then fasten to face plate by machine screws through slots. The bosses may now be turned off on one side, the rod turned over and faced off on the other side to $\frac{3}{8}$ " thick, to fit fork. Then enlarge holes to $\frac{3}{8}$ " and $\frac{5}{16}$ " respectively for crank-pin and wrist-pin. The balance wheel should be drilled and reamed to $\frac{1}{2}$ ", then mounted on an arbor and the rim turned on edge and both faces; diameter, $7\frac{1}{4}$ ", face, 1". A wheel suitable for this purpose may often be found in the scrap iron pile at a junk dealer's or taken from some old machine. The exact dimensions are not essential, but it should be fairly heavy and run true. If the builder makes his own patterns, it may be found easier to make a solid webbed wheel rather than one with spokes. Both ends of hub should be turned true while wheel is on arbor. The crank is a small iron casting which should be drilled to $\frac{1}{2}$ " in the shaft end. The crank pin end may then be drilled and tapped with $\frac{5}{16}$ " standard thread, just $1\frac{1}{2}$ " from centre of shaft hole. Care should be taken to get the holes parallel. The shaft may be made of cold rolled steel and will need no turning. Crank pin may be turned from the same stock. Balance wheel may be secured to shaft by a set screw, and the crank by a taper pin driven through both. This method of fastening would not do in a gas-engine where there are severe shocks to take care of, but the motion of a caloric engine is very smooth and easy.

The heating cylinder and transfer piston may now be taken up. The cylinder is made of a piece of 3" iron pipe 10" long. It should be threaded for four inches on each end. The threading may be done by the steam fitter who supplies the pipe, or it can be done in a lathe by mounting on a rough arbor. A piece of hard wood will do for an arbor, if supplied with iron centres. It should be made with the large part a little shorter than the pipe so that the ends may be trued up and bored out inside for a short distance. The inside of the ends may be threaded so that the heads can be screwed in if desired, but this is not necessary. The back cylinder head is simply turned up, with a shoulder making a drive fit with the end of cylinder, or threaded to fit as the case may be. The front head is the same, except that it has a hole drilled and reamed for $\frac{3}{16}$ " piston rod. Both heads are cast from one pattern, the central boss on the back head being used as a chuck piece and then cut off. If the heads are not screwed in they should be fastened by drilling and pinning. In either case, the joints are to be made tight with red lead. The transfer piston may be made of 18 or 20 gauge sheet iron seamed together at the joints. This is a tin-smith's job and should be left to him. The heads of piston should be of heavier iron. The piston rod should be secured to the front head, and three strips of sawed brass about $\frac{1}{16}$ " thick and $\frac{3}{16}$ " wide, should be riveted along the sides before piston is put together.

These are for the piston to slide upon inside cylinder. Diameter of transfer piston is scant $2\frac{1}{8}$ ". The joints in the piston need not be particularly tight, and one or more small holes should be drilled through the side to prevent air pressure on inside when heated. The piston rod is a piece of cold rolled steel $\frac{3}{16}$ " diameter and $5\frac{1}{4}$ " long, threaded at each end. The outer end is screwed into a small knuckle joint, which may be made of sawed brass. The connecting rod is also made of sawed brass, $\frac{1}{8}$ " x $\frac{5}{16}$ " and is 4" from centre to centre of holes. The crank pin for transfer piston is turned up from soft steel, driven into a hole in one spoke of fly wheel, $1\frac{1}{2}$ " from centre, and riveted over on back. The outer end may be drilled for a small split pin, and the connecting rod held on by a washer under the pin.

This completes the work on the moving parts of the engine. The bracket on side of power cylinder should now be drilled, the holes spotted through on to the front head of heating cylinder. These holes should then be drilled and tapped for fastening on the cylinder. A hole should now be drilled in the side of the cylinder and tapped for $\frac{1}{4}$ " pipe. A short nipple is screwed into this, and an elbow and another short piece attached to connect with power cylinder. After the piping is made up, the screws fastening to the power cylinder may be put in. All that now remains is to provide a casing or fire-box on the

hot end of the large cylinder. The foundation of this is a ring of heavy sheet iron cut out to fit tightly around the cylinder. The shell of the fire box is made of two layers of sheet iron with asbestos between. It should be open at the bottom for the burner and have a suitable flue at the top through which the products of combustion may escape. As the exact shape of the fire box will depend on the burner, this is left to the builder. In any case there should be a space at the sides and end of the cylinder, to give all possible heating surface. The description of a kerosene burner for this engine will be given in a future issue

MICROSCOPY FOR AMATEURS.

S. E. DOWDY, M. P. S.

V. Testing the High Power Lens.

Now, with regard to the question of the aperture of the lens, suppose, for example's sake, we were observing the minute markings on a diatom valve with a narrow apertured lens of good workmanship. If the diatom was a suitable one, we should probably see a series of fine lines close together, these becoming more apparent if oblique illumination is used. If a wide apertured lens was now substituted, though of exactly the same magnifying power, it is very probable that these lines would be shown as what they really are—vis. a series of beads or dots, thus affording an example of the value of aperture in an objective. Supposing we now replace our narrow-angled lens and tried the effect of various eyepieces on the image yielded by it, we should find that when we got to eyepieces magnifying more than about ten diameters the image would greatly deteriorate in quality and break down, as it is termed. On the same object, however, the wide-angled lens would work with much more powerful eyepieces without showing much falling off. This is, of course, explained by the theory on which images are formed in compound microscope. The primary image formed by the objective is magnified by the eyepiece; any imperfection is, therefore, shown in proportion to the magnifying power of

the eyepiece employed. This is the reason why powerful eyepieces are of little use to the student, because his lenses, owing to their want of aperture, would break down, or else not admit sufficient light with such eyepieces. The real value of aperture, therefore, is that it imparts brilliancy of image, better definition and resolving power to a lens. It should not, however, be forgotten that increased aperture means vastly increased skill to impart the necessary corrections for the elimination of spherical and chromatic aberration; so that, unless the workmanship be really good, the increase in aperture may be more than counter-balanced by the presence to a certain extent of these defects.

If possible, it would be a good plan for the student to beg the loan of a large-apertured $\frac{1}{4}$ " lens, and try it under these conditions against his own *comparatively* narrow-apertured objective of the same focal length. I say "comparatively narrow-apertured," because, as before mentioned, students' lenses are now mostly made with wider angles than they used to be, owing to the recognition of the fact that increase of aperture, with good workmanship, means increase of resolving power and improvement in definition. Unfortunately for those of limited means, increase of

aperture involves a big increase in price, owing to the skill and care required to eliminate spherical and chromatic aberration under such conditions. If possible, though, it is a good plan to pay the extra money asked for, and substitute a fairly wide angled 1" lens for the lower apertured one likely to be supplied with a student's stand. The increased cost will be fully repaid, because the wide angled objective, if by a good maker, will admit more light, define better, and, what is an important point to anyone not provided with a large selection of lenses, will stand much deeper eyepiecing. It may have a shorter working distance; but that is not a very grave defect, providing the focal length is anything over $\frac{1}{2}$ ". A low-power lens can be satisfactorily used, even by the beginner, except perhaps for dissecting purposes.

I should not advise the student, however, even if he can afford it, to purchase a large-apertured high-power dry lens, because such an objective, though yielding finer results in experienced hands, is not an easy thing for the beginner to manipulate. For one thing, a slight alteration in thickness of cover or length of body-tube will impair the image shown by it; but the most serious drawback would be that its working distance would be extremely short, perhaps so much so that only the thinnest of cover-glasses could be used over objects viewed through it.

The term "dry lenses" has been used several times in explaining the manipulation of the ordinary objectives the student is likely to require. The adjective is used to distinguish such lenses from those which have their fronts immersed in a liquid, such as oil or water, and which are therefore known as "immersion objectives." It must suffice to just mention their existence, as unless the student is taking up the study of bacteriology, he will not require a lens of this kind. Without therefore, entering into an explanation of the principle on which this type of lens construction is based, which would involve the introduction of such terms as refraction and dispersion, and imply a previous knowledge of optics on the reader's part for a proper understanding, it will be, perhaps, sufficient to say that immersion lenses have a greater working distance than dry ones for the same aperture, and are

also less sensitive to thickness of cover-glass. Of this type of lens, $\frac{1}{15}$ " oil immersion is the one most frequently used in biological and bacteriological work. Such a lens having an aperture of 1.25 can be obtained for \$25 upwards, so it will be seen that an objective alone may cost much more than a complete student's microscope. Immersion lenses are not difficult to use, it being necessary merely to put a drop of either cedar oil or water, as the case may be, on the cover-glass surmounting the object. The objective is then lowered by the coarse adjustment until its front lens touches this liquid, when focussing is completed, without removing the eye from the body-tube, by means of the fine adjustment. After use the lens-front should be carefully wiped with absorbent cotton-wool before replacing it in its case. Enormous magnifying powers up to seven thousand diameters may be obtained by the use of such lenses and suitable eyepieces; but such magnifications are seldom required (except in bacteriology and similiar work) and cannot always be relied upon, like the images obtained with a lower-power lens.

To test an oil immersion or water immersion lens it should be tried upon stained bacteria, or suitable diatoms, but as such a lens does not comprise part of an ordinary student's outfit, we can leave the matter until the observer has sufficient microscopical experience to suggest the best method for such an objective. It will then be time enough for thinking of purchasing such an article. We have now shown how the lenses supplied with the microscope, or purchased subsequently, may be tested, and by the time the student has done this, he should have arrived at the best method of handling the instrument for ordinary working purposes. A few words, as to certain precautions that should be used in actual working may not be amiss at this point.

It is often thought that work with the microscope and artificial illumination ruins the eyesight. Such is not the case, if care be taken to only use sufficient light to clearly make out the details of an object, to only work when in good physical condition, and only so long as no strain is felt on the eyes. The yellow glare from the lamp employed should be toned by passing it through blue glass, and this can be done by either

using a blue glass chimney, or by placing a disc of the glass in the stop-carrier of the substage condenser. Powerful eyepieces should be avoided as much as possible, and only sufficient power used to clearly make out the detail looked at. It is also a good plan to get into the habit of using the right and left eye alternately, and to keep the one open whilst the other is at the eyepiece. This may seem difficult at first, but is easily acquired by a little practice. It has been noticed that whilst the eyes of one accustomed to use the microscope to a great extent may be rendered less susceptible to intensity of light, they become much more sensitive with regard to perceiving fine detail, which is only what might be expected. With regard to using both eyes, the beginner may be tempted to say. "Why not purchase a binocular microscope, and always use both eyes? Unfortunately, however, binoculars cannot be used to much advantage except with low-power objectives, owing to loss of sight from the prisms and other optical reasons. Some of the best class of students' stands can now be obtained fitted with binocular body-tubes, but the novice is not advised to purchase one for reasons too numerous to mention to be gone into here, though, if he likes to obtain one in which the monocular body can be easily substituted, there will be occasions on which it can, as a binocular, be used to advantage.

Having described the instrument and its lenses, a word or two with regard to the use and purchase of the various adjuncts to it, known as accessories, may be said. The student will not be long in finding that to successfully carry out many operations with the microscope he must employ one or other of these adjuncts. For instance, if he wishes to look at an opaque object, *as such*, he must have recourse to the use of what is known as a "bull's eye condenser," or if he wishes to rapidly change his lenses he must, unless he unscrews them every time, employ a nose piece, and so on.

Accessories can always be purchased separately or picked up second-hand, and such should include, besides the bull's eye condensers and nose piece just mentioned, a live box, micrometers, a cheap form of camera lucida, and some form of polarising apparatus. For mounting objects a

pair of forceps, scissors, watchglasses, slides, covers, and the usual paraphernalia will be requisite, besides a good form of hand lens, either the ordinary single lenses in frames or, preferably a compound lens, such as those termed aplanatic, etc., by the makers.

Space will not allow of more than the briefest indication of the use of each of the more generally required accessories, and the beginner is advised to first procure as good a textbook on microscopes as he can afford, and to carefully make out the specific use and scope of each article before purchasing it; otherwise he may obtain his experience in a not unusual fashion by paying rather dearly for it. I would, however, warn novices from buying old and out-of-date works on the microscope, as in the light of recent improvements and discoveries they are only misleading, and apt to create erroneous impressions. For the benefit of those quite ignorant of the use of the microscope and its accessories I might briefly describe those adjuncts which I have mentioned as being required to complete the student's microscope outfit.

The Bull's-Eye Condenser.—This useful piece of apparatus consists of a plano-convex lens, mounted in a sliding arm attached to a pillar so that any required position of the lens may be attained with a little manipulation. The specific purpose of this accessory is to illuminate opaque objects by concentrating and bringing to a focus light from the lamp upon these specimens, which could not from their opacity be viewed by transmitted light from the mirror. It can only be satisfactorily used with low power objectives, so that its usefulness is to a certain extent restricted, still, it is a useful accessory for all that. Bull's-eye condensers vary in price from about \$2.00 upwards, according to size of lens and method of mounting, but a small one will answer the beginner's requirements.

The Nose Piece.—This is one of the most useful and time saving devices the worker with the microscope can possess. It consists of a peculiar shaped revolving double collar, rather difficult to describe, but very simple in construction and working. By its means objectives of varying focal length can be employed and rapidly changed without unscrewing or screwing in the lenses each time into the body-tube of the instrument.

Both time in working and wear and tear on the objective screw threads are saved, thus constituting this little addition to the outfit a most welcome. Nose-pieces are made in either brass or aluminum to carry two, three, or sometimes four objectives. The student is advised, however, to obtain one to carry two only, because all the weight in some forms of instrument comes upon the fine adjustment, and a quadruple nose-piece loaded with four objectives is no light weight for a delicate mechanism and stand. The price of this necessary ranges from \$2.50 upwards, for simple as it is in appearance, it requires to be very carefully made to insure accuracy in centring the lenses. One of its chief uses to the student would be in finding objects when high magnifying powers were being employed. For instance in picking out a certain diatom on a mixed slide, a low-power lens would be used, the diatom being put into the centre of its field; the nose piece would then be rotated to bring the high-power lens to bear upon it, when, on focussing, the diatom should appear in the centre of the field of the higher-power lens.

A *Live Box* consists of a raised ring of brass mounted in a small brass plate, and having a circular glass resting upon it. Over this ring another is made to slide, this upper ring also encircling a glass cover. Any object placed on the lower glass, and the cover put on, is therefore in a sort of box or cage. This piece of apparatus,

costing anywhere from 75 cents upwards to \$2.50 or thereabouts, is principally used in observing pond life, but can be put to a variety of purposes. It can, however, be dispensed with, as an ordinary shallow cell can be made to answer fairly well in its place.

Micrometers consist of glass slides or circles, ruled in minute parts of an inch, or in millimeters. They are, of course, for measuring specimens viewed under the microscope, and are also of use in determining magnifying power. The methods of using them can be seen in any good textbook, and they are useful little appliances. Two would be required if the student wished to determine visually the dimensions of objects, one ruled and mounted as an ordinary 3" x 1" slide, the other as a circle to drop into the eyepiece. The usual cost is \$1.00 each for those ruled to the $\frac{1}{100}$ " and $\frac{1}{1000}$ ".

A *Camera Lucida* for the microscope is an appliance for making accurate drawings of objects. The simplest form, and the one most suitable for the student is what is called Beale's neutral tint reflector, costing about \$1.50. There is a certain knack in using both forms of camera lucida; but when once picked up it is not readily forgotten, and accurate drawings, or rather tracings to scale, may be made by anyone.

Photography is, however, rapidly displacing this method of recording observations, though, of course, photography is not always applicable.

English Mechanic.

LANTERN SLIDE MAKING.

R. G. HARRIS.

II. Slides by Reduction on Commerical Plates.

In the previous chapter a very elementary description was given of the production of a lantern slide with the aid of a printing frame. The method given would scarcely satisfy any but a beginner anxious to produce a lantern slide without venturing too far into the intricacies of the subject. Complications and refinements are sure to attract the worker before long, the printing frame will be discarded for the camera, and the black colors gradually give way to warmer

ones. To anticipate the desires of the worker, it will be desirable to devote the present chapter to the description of some arrangement for producing lantern slides by reduction with a camera, involving the use of both artificial light and daylight.

It was remarked earlier in these chapters that for any negative larger than quarter-plate it was essential to resort to camera reduction for producing lantern slides if the whole of the subject

was wanted in the slide. The opinion may also be hazarded that as the lantern slide worker becomes more competent he will incline more and more towards camera work as a means of slide making. Some processes for making lantern slides, though giving most excellent results, are too slow to permit of exposures in the camera, and one is compelled to reserve them exclusively for contact use, but in case of a plate like the lantern plate of commerce, which is available either for contact or reduction, the camera will be found to be the most satisfactory means of obtaining a lantern slide. Even in the case of quarter-plates, which have been taken with a lens of fairly long focus, it is seldom that the slide would not have been better for the inclusion of the whole of the subject.

The camera for use in making slides by reduction may be the ordinary field camera if it is of the "stand" camera pattern, but where lantern slide work is followed systematically it is most desirable to have a camera relegated to the work of lantern-slide production. The arrangement which is used by the writer is simple in construction, and does all that is required in making lantern slides by daylight reduction. It consists of a baseboard about four ft. long and one ft. wide; between two parallel guides running the whole length of this baseboard slides a block of wood the same size as the base of the camera, and having a ledge at either end to hold the camera firmly. A negative holder, with carriers for various sizes of negatives, slides at the other end of the baseboard, and the whole enables lantern slides to be obtained from negatives 15" x 12" down to $4\frac{1}{4}$ x $3\frac{1}{4}$. The camera used on the baseboard is a square half plate, but, of course, any camera can be adjusted for use in a similar manner. A very convenient instrument is one of the square sliding-body cameras made for wet plate work, which might be bought for a small sum. If a camera of this description is firmly affixed to the block sliding between the parallel guides, it makes a most efficient camera for lantern slide reduction.

The lens should not be of very long focus, or the exposures will be inconveniently protracted. Four and a half inches is a convenient focal length, and although a single landscape lens is permissible, it is better to use a lens of rapid

rectilinear form to avoid any possibility of distortion. The whole arrangement is inclined so as to command a clear view of the sky. If it is possible to exercise any choice, a northern aspect should be selected, as then no trouble is experienced from sunlight striking the negative. Should a north or northeastern aspect be unobtainable, or should such objects as trees and chimneys project into the field of view, it is convenient to cover that part of the window used with one or two thicknesses of tissue paper, or, which is even better, a single thickness of white demy paper. Two rods are used connecting the camera and negative holder; these are simply loose rods laid across to bear the focussing cloth, which is thrown over previous to exposure, to make a dark chamber between the lens and negative, a precaution that prevents any diffused light operating on the negative from the rear. Using the arrangement for daylight exposures, with a four and a half inch lens and $\frac{1}{16}$ " stop, the exposures with ordinary lantern plates will be about twenty seconds for black colors and up to three minutes for warm colors, the negative reduced being a half plate, and the light outside good, diffused spring light.

It will be impossible here to go into the question of conjugate foci, so intimately associated with all matters of enlarging and reduction. The better plan for the beginner is to arrive at the correct distances that are necessary between the lens and plate on the one hand, and between the lens and negative on the other, by a system of trial and error, remembering that the greater the reduction the further the negative has to be from the lens, and the less camera extension needed. Once the correct distances have been found, marks made on the baseboard for the positions of the camera and negative holder will enable them to be speedily adjusted on all subsequent occasions. As a rough guide for preliminary trials, the accompanying table may be of assistance to the beginner.

Reduction in the camera by the aid of artificial light is quite easily accomplished in the absence of daylight, and the majority of lantern slide workers will find artificial light more convenient, as work can be carried on in the evening. The apparatus is that used in daylight reduction so

far as the baseboard and camera are concerned, but is is, for convenience sake, used horizontally upon a work bench. Two Welsbach burners constitute the source of illumination, and the light is diffused by passing through two thicknesses of tracing paper placed over the negative holder. The burners require adjusting at a sufficient distance from the tracing paper to give even illumination, and to this end they are fixed on a sliding stand.

It will be seen that this method of work has very serious limitations. Should it be necessary to enlarge slightly the image so as to exclude from reproduction some unessential portion the camera fails utterly. Nor is it possible to use it for any other size than for which it has been made. Printing by "contact" necessitates little apparatus beyond the ordinary printing frame as used for paper prints. Ingenuity has been expended in devising printing frames specially for

Focus of lens	Half-plate Negative to $3\frac{1}{2} \times 3\frac{1}{2}$	Whole Plate ($8\frac{1}{2} \times 6\frac{1}{2}$ to $3\frac{1}{2} \times 3\frac{1}{2}$)
	14 inches negative to lens	21 inches negative from lens
$3\frac{1}{2}$ inches	$4\frac{1}{2}$ in. focussing screen to lens 18 in. negative from lens	4 " screen " " 27 " negative " "
$4\frac{1}{2}$ inches	6 in. screen from lens 20 in. negative from lens	$5\frac{1}{2}$ " screen " " 30 " negative " "
5 inches	$6\frac{1}{2}$ in. screen from lens 24 in. negative from lens	6 " screen " " 36 " negative " "
6 inches	8 in. screen from lens	7 " screen " "

The lens for use with artificial light should have as short a focus as possible to secure the maximum amount of illumination. A $3\frac{1}{3}$ " rectilinear is very convenient if of good quality, so as not to require stopping down before definition can be obtained. In place of the Welsbach burners an arrangement may be substituted by burning magnesium ribbon, or a flash lamp. The burners, however, are by far the most reliable illuminant. Magnesium ribbon is most convenient for contact exposures with very slow plates, but for reducing purposes its use is attended with some degree of uncertainty.

The simplest way of camera reduction, when the negatives are all of one size, is to use a "fixed focus" camera. A rectangular box of the size of the negative to be reduced has provision made for holding the negative at one end. At the opposite end of the box is a frame with $3\frac{1}{4} \times 4$ " aperture, into which a lantern plate is placed and held in position by a spring, a light tight lid fitting on the end of the box. The lens is fixed near the middle of the box in a rigid frame, in the position to focus accurately upon the lantern plate. All that is necessary is to place the negative in position at one end of the box and a lantern plate at the other, to cover up both ends until the apparatus has been illuminated, and then to expose by removing the cover of the negative.

use in lantern slide work. They are convenient when a slide is printed by contact from some portion of a negative very much larger than the lantern plate. But the slide maker may be contented with an ordinary printing frame, merely putting underneath the negative a piece of plain glass the size of the frame for the negative to rest upon. By so doing, no danger of fracturing the negative from the unequal pressure of the lantern plate may be feared.

Photography.

In Algeria, steps are now being taken for the production on a large scale of natural soap from the tree known as *Sapindus utilis*. This tree, which has long been known in Japan, China, and India, produces a fruit which, when ripe, is about the size of a chestnut, smooth and plump. The color varies from yellowish-green to brown, and the inside is of a dark color and contains an oily kernel. If carefully chosen, a cutting from this tree in the course of two years reaches the height of 6 ft.

It does not, however, reach maturity until its sixth year, when it bears from 25 to 100 kilogrammes of fruit, which are ready for picking towards the end of autumn. The methods of treating the fruit to obtain from it its saponaceous properties are varied, water or alcohol being generally used.

PATTERN MAKING FOR AMATEURS.

F. W. PUTNAM.

I. Something about Suitable Wood.

This series of articles on pattern making will be so written as to be of value to those amateurs whose stock of tools is not large, and to those whose practical experience with model making is very limited. It is surprising to see the amount of ingenuity displayed by some model makers in attempting to supply a lack of pattern making ability. If the same amount of time and patience had been properly directed, the model maker would have been able to make patterns, not for one model alone, but for about anything else he wished to make.

It is not pleasant, after much time and labor have been expended upon the wooden model, to hear the decision of the founder that it is quite impossible to mould and cast it in metal. Yet nothing is more common, and the cherished pattern has frequently to be cast aside and replaced by one of totally different construction. A pattern maker, in addition to skill in the use of tools, must be able to make drawings and sketches as well as read them, as it frequently happens that the pattern must have a shape differing from that shown in the drawing. He must therefore be able to make the modified drawings necessary for his work, and so must thoroughly understand the methods of the foundry. With these thoughts in mind the present series of articles are written.

These articles, then, are to take up also the principles of moulding and casting, and the series will be long enough to give instruction to such an extent that the model maker will be able to embody his ideas for castings in patterns, to adapt means to ends, and to avoid making the final results subservient to means. I hope to be able to explain foundry practice in such a way as to prevent the reader from making any mistakes in his designing, which might lead to expensive castings because of their being impractically de-

signed and thus costly to make through defective knowledge of moulding.

Having finished our introduction, let us first examine very briefly something of the history of pattern making. The art of moulding has come down to us from a very remote period we find evidences of its practice by the most ancient nations in articles found among the ruins of temples, palaces, fortresses and cities. Those learned men, who have read our old earth's unwritten history, tell us that in ages far remote, men made tools and contrivances of bronze, which being an alloy, necessitated the fusion and casting of the metal. This casting involves the use of patterns, and pattern making may therefore lay claim to the highest antiquity.

Lack of space forbids any lengthy review of the history of pattern making, and I will only say that, whatever the source of the technology of the art, we in our own day can show nothing superior, either in design or execution, over the work of men whose names and methods are lost. The more modern idea of the division of labor has made pattern making a distinct art. A generation ago a machinist was required to be able to work upon both wood and metal; he constructed his frames of wood and made the patterns for his cast metal work; he was today a woodworker, tomorrow a lathe hand and the following day a vise hand.

In this art, there are to be considered many details that are seldom or never shown in drawings, such for instance, as the amount necessary to allow on the pattern for finishing certain parts of a casting, and on what part such allowance is required, and the method which has been proved by experience to be the safest and most expeditious in moulding a certain kind of pattern. But above all these considerations lies the fact that drawings merely show the shape which the fin-

ished pattern is required to have, leaving it entirely to the judgment of the pattern maker to select in what way the various pieces of wood (of which the pattern is constructed) shall have the grain lie, and how they shall be fastened or held together. Experience is a great teacher, and the amateur should always keep a record of the work which falls under his observation, in which record the sizes and proportions of the work, the method of putting it together, the time taken in its production, and (if possible), whether the

it lies for some time in a dry and airy place it will lose nearly half its amount of water by evaporation. During the process of drying, timber decreases in volume or *shrinks*. If exposed again to moisture it increases in volume or *swells*.

Timber is often used under condition which do not permit it to shrink or swell freely in all directions; consequently it shrinks or swells more in one place than in another. When one part of a piece of timber shrinks more rapidly than an adjacent part, the wood *cracks*. If, on the other

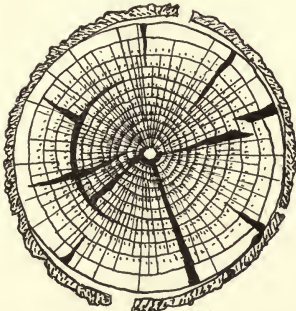

FIG. 1.

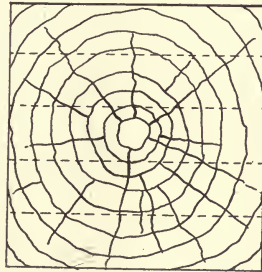

FIG. 2.

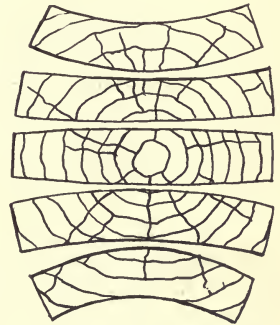

FIG. 3.

castings were satisfactory, noting the defects in the latter, if any, together with suggestions for the remedy for those defects. A pen and ink sketch of the patterns made in the margin of the record will add to its usefulness, besides accustoming the hand to make correct sketches and a clear explanation of the work done. The operative's intelligence will be much exercised in the shaping and building up of patterns, depending as this does on the strength of the material of which the casting is to be made, the strength of the pattern itself and the desirability of its moulding well.

Before we commence the actual making of patterns it will be well to give some instructions as to wood and other materials to be used in this work and also to anticipate some of the difficulties that may be met in the use of tools, etc. In selecting stock for patterns the following must be considered:—First, its tendency to warp; second, its tendency to bend, and third, its tendency to shrink. Newly felled timber contains sometimes as much as 50 per cent of its weight of water. If

hand, one part swells more than another, or if the adjacent part meets with some obstacle to its expansion, the timber changes in shape, it becomes *warped*.

In many kinds of trees, when the trunk is sawn across, a considerable difference may be observed between the appearance of the inner and older and the outer and younger concentric annual layers. The inner layers making up the *heart* of the tree are generally firmer and closer in texture and darker in color than the outer or *sap* wood; these outer layers being less compact, lighter in color, and full of sap. The parts nearest the sap wood shrinks more rapidly than the heart wood and cracks or checks are the result.

Fig. 1 is a sectional view of a log showing very clearly the annular rings and the checks as just referred to. Fig. 2 is a sectional view of a log with the round edges removed, the dotted lines indicating the cuts taken in sawing the log into parallel longitudinal cuts. Fig. 3 shows how the planks will shrink as the moisture dies out. The broadest portion shown shrinks least in breadth,

most in thickness; least nearest the centre, most near the sides. The outside planks, however, shrink most in breadth, in the direction of the annual layers, and least in thickness. The planks lying between shrink differently on different sides, and become convex nearest the centre and concave toward the outside because of the corners being drawn up.

It will be seen then that planks containing the most heart wood warp the least, and so, in order to reduce the tendency to warp, the boards or planks are sometimes sawed at right angles to the annular rings, making four pieces. Each piece is then laid back down and sawed into boards. This method, called *quarter-sawing*, is wasteful in lumber but reduces warping to a minimum, and in certain kinds of wood, as oak and sycamore, produces very beautiful results on account of the manner in which it intersects the medullary rays.

For our work, pine will be the most servicable of the different kinds of woods used by the pattern maker. Good stock, straight grained and free from knots should be procured, as the difference in cost between good and inferior wood in the small pieces required for each pattern is as nothing in comparison to the value of the work put into it, and a pattern may easily become valueless through the wood being checked or not thoroughly seasoned.

Pine, if carefully selected, is easily worked and possesses, at the same time, strength enough for all but the most delicate kinds of patterns. The chief objection to pine for small patterns is that it is soft and soon gets dented from repeated moulding, but this objection we need not consider, as the reader is not likely to need more than three or four castings from the same pattern. Also, by carefully shellacing the pine patterns, we shall be able to make the surface very nearly as hard and glossy as hardwood ones, and so secure the same smooth castings.

When pine is straight grained, the marks left by the saw on a plank will show an even roughness throughout its length, the softer the plank the rougher the appearance of the edges. If the surfaces sawed seem to be smooth, the stock will generally be found to be hard and difficult to work. When the surfaces sawed are rough in

spots and smooth in others, the grain is crooked and it will be found that in planing, the grain tears up and a smooth surface is impossible.

When a great many castings for fine work are required from a pattern, a pattern is made for an iron casting to be finished as a pattern. These iron patterns are very durable, leave the sand easily and will not warp. They are, however, expensive to make, and so mahogany is very extensively employed for fine or durable pattern work. Mahogany warps but little and does not decay, so it is really the most desirable of all woods used in pattern making, where the first cost need not be considered.

Bay wood, an inferior and much cheaper kind of mahogany is much used, especially in England. If you buy bay wood, choose it light colored and get it as straight grained as possible, and without any fancy markings. Avoid a board that is "fuzzy" or "wooly" on the surface as it does not work well, this being opposite to the grain of pine stock, which when rough from the saw is generally soft and easily worked.

Next to mahogany we may rank cherry. It is a very durable wood, but is much more liable to warp or twist than mahogany and is rather hard to work. Small patterns and core boxes are sometimes made from hard maple, while for very fragile patterns sycamore is sometimes used, as it is so white and close grained that you can draw neatly upon it, and see your lines distinctly when paring or carving, a most important point in accurate work. In buying small pieces of wood, I may say that most lumber dealers are willing to cut off a piece of board at a little extra cost per square foot. Do not buy, however, from a builder or cabinet maker if you can avoid it, as they will generally charge a much higher price.

It is reported that some students of Missouri University, at Columbia, Mo., have discovered that if an ordinary telephone transmitter be connected in a certain manner with an electric arc lamp, the latter will produce whatever sounds are made before the transmitter, and with greatly amplified volume. The arc lamp appears to act as a giant receiver, reproducing speech, shouts, laughter, etc., with immense volume.

BOOKS RECEIVED.

SILVERWORK AND JEWELRY. H. Wilson, D. Appleton & Co., New York, 7 $\frac{3}{4}$ x 5, 346 pp. 169 illustrations and 16 page plates. \$1.40 net.

WOOD CARVING. George Jack, D. Appleton & Co., New York, 7 $\frac{3}{4}$ x 5, 310 pp. 77 illustrations and 16 page plates. \$1.40 net.

These two books are the second and third to appear in the "Artistic Crafts Series of Technical Hand Books" which is destined, as the number and range increases, to become a valuable source of information and instruction. In the first book above mentioned, the author gives practical instruction in the use of the tools and the making of quite a range of metal work, including the hammered work now so popular in many manual training schools. The numerous examples illustrating the different kinds of work are all well selected and artistic.

The treatment of wood carving is essentially artistic, and because of this fact has decided value to a student of the subject who would avoid being misled in the early stages of his work, before his mind has been trained to clearly distinguish between good and poor design. The "technique" is described as clearly as the subject will permit, the tools and their appropriate uses, being shown by numerous illustrations. An excellent book.

MACHINE DESIGN, PART I. Charles L. Griffin, S. B. American School of Correspondence, Chicago, Ill. 9 $\frac{3}{4}$ x 7, 74 pp.

To those who are unable to attend a resident technical school, the correspondence system of instruction is of decided value. Thousands of men have utilized this method of increasing the knowledge with manifest advantage, both intellectual, and financially, to themselves and their associates. It is necessary, from the nature of the methods used, that instruction papers be plain and as complete as possible, to enable the student to make suitable progress without unnecessary loss of time. This paper on machine design certainly complies with these requirements, and contains much excellent instruction as to proper methods of working when original work is attempted.

"TECHNICS" is the name of a new magazine published by George Newnes, Ltd., London, for "technical students." If the high standard of the first number be maintained, it should certainly find many readers. Among the subjects there presented are:—Charlottenburg, the Berlin Technical High School; Radium, Mural Decoration, Modern Art of Dyeing, Textile Design, Elementary Technical Education, Continuous Current Dynamo, Rapid Cutting Steel, and others. The International News Co., New York, are American agents.

A new metal which is similar to aluminum, but still of lesser weight, has been discovered by the French engineer Albert Nodon, and called "nodium," after him. It is manufactured by an electric process. In color, luster, and structure it is almost exactly like steel. Its specific weight when molten is only 2.4. Its resistance against breaking is given as about 20 pounds per square of 0.04 inch. Its constancy in the air is higher than that of aluminum. Its ductility is between 6 to 8 inches; the malleability can be compared to that of bronze. It melts at about 600°. It is suitable for being cast into forms. The conductivity for the electric current is as high as that of copper of equal weight. If natural power especially water power, can be used for its manufacture, the cost in round figures is about 15 cents per pound. The inventor expects numerous uses of nodium in the near future, especially for electric wires and cables, for light but strong parts of motor cars, torpedo boats, men-of-war, street cars, military outfits, air ships, etc., and for castings in place of bronze, German Silver, and similar metals. Nothing definite has yet been communicated as to the chemical composition of nodium nor as to the mode of its manufacture.

One of the points of interest in the motor-car or automobile development is the fact that the facilities offered by up-to-date automobiles for traveling long distances quickly and easily, and without regarding to fixed time tables, increases the radius of the residential section of a city, thus combining the advantages of country life, with a command of city conveniences.

AMATEUR WORK

77 KILBY ST., BOSTON

DRAPER PUBLISHING CO., PUBLISHERS.

A Monthly Magazine of the Useful Arts and Sciences. Published on the first of each month for the benefit and instruction of the amateur worker.

Subscription Rates for the United States, Canada and Mexico \$1.00 per year. Single copies of any number in current volume, 10 cents.

TO ADVERTISERS.

New advertisements, or changes, intended for a particular issue, should reach the office on or before the 15th of the previous month.

Entered at the Post-office, Boston, as second-class mail matter
Jan. 14, 1902.

MARCH, 1904.

The article on the "Hot Air Engine" in this issue is to be followed by one on a "Dynamo" and one on a "Storage Battery;" all of about the same capacity, making together a nicely designed combination which should be of much interest to our readers.

Our premium offer of turning lathes is meeting with the success which we felt certain it would when making the same. Two letters received from fortunate winners, and given in this issue, are the best testimony we can offer as to the value of these premiums. As a lathe is such a necessary tool to the amateur, and as our offer places a good lathe within the reach of nearly every reader of the magazine, we feel confident that many others will be equally successful in securing lathes at an early date. As we have a large stock on hand, and in process of manufacture, premiums will be sent promptly on receipt of the necessary subscriptions. We also announce that the following accessories are being designed and made, which will add materially to the usefulness of the lathe;—Saw table for circular saw, 3 inch for metal and 5 inch for wood; saw arbor for same and for 5 inch emery wheel; drill chuck for holding drills, and fret saw attachment. We shall probably be able to announce terms for securing these attachments in the next issue.

The financial demands of model making and experimental work are frequently greater than some of our younger readers find it convenient to meet with their ordinary income. If they could carry on a little business, which would be dignified and agreeable, and yet not interfere with school or home duties, their income could be considerably increased. To assist such of our readers as will be interested in a business of this kind we make the following offers;—The premiums given for three subscribers will be given;

1. For the best article telling how boys can make money, without capital, in a place over 10,000 inhabitants.
2. For the same, without capital, in place under 10,000 inhabitants.
3. For the same with a capital not exceeding \$5.00 in a place over 10,000 inhabitants.
4. For the same in a place under 10,000 inhabitants.

All articles must be received not later than April, 10, 1904. Articles not awarded a prize, but which are of sufficient interest to publish will be awarded a premium given for one subscriber. Articles should contain not over 300 words, be written on one side of the paper with one inch margins on all sides.

WEST LYNN, March, 3, 1904.

DRAPER PUB. CO.,
BOSTON, MASS.,
Gentlemen:—

The lathe was received in O. K. condition, and I want to state that it is a little beauty; more so than I expected. I set it up the same afternoon received, and had it running. It is a very smooth running machine, and will make a very handy tool. I would like to recommend it for both amateurs and professionals; especially the easy way of getting it. I shall be pleased to show it to anyone interested, living in my locality. It is worth trying for twice over.

C. A. Carlsson.

ALLSTON, Mass, March, 2, '04.

DRAPER PUB. CO.,
BOSTON, MASS.,
Gentlemen:—

The lathe received and in first class condition. The scraped bed was an additional surprise to me. The alignment was correct and the bearings stood four hours continuous running without heating. I am much pleased with the lathe, and earnestly recommend it to all readers of AMATEUR WORK.

A. Gordon Hentz.

HOW TO MAKE A SET OF WEIGHTS.

ROBERT GIBSON GRISWOLD.

The following described set of weights is intended to go with, or be used with, the balance described in the last issue of AMATEUR WORK. The balance cannot be of much use without a set of good, accurate weights, and while the set if purchased from the maker's would be very accurate, they would cost about \$10. Since every weight must be made by hand, however expensive it may be, the amateur can make them as well as the manufacturer.

In the first place, a set of weights need not be exactly a counterpart of the international standard, which the manufacturers always make them. The value of any set of weights lie in their being exact multiples or sub-multiples of each other, as every weight is simply relative and nothing absolute can be made. The system of weights generally used in all technical work, especially chemistry, physics and photography, is the international gram, the equivalent of which is a cubic centimeter of distilled water at its maximum density.

Now when a formula requires that the weight of a certain substance shall be say 9.647 grams, and that another ingredient shall weigh 7.523 grams, it makes no difference whether the weights with which the above ingredients are weighed out are exactly duplicates of the international standard or not, so long as the system to which the respective weights belong exactly agrees with its several units. To make this still plainer, the weights merely express the number of parts to be taken, so that if the unit to which the part is referred is the same in each case, the ratio between the ingredients will be correct.

Now in order that a starting place may be had from which to work, it will be necessary to borrow from some druggist or chemist a few weights for comparison. We will consider the making of the set of metric weights specified in the accompanying table denominations.

The above set will permit accurate weighings to be made from 200 grams down to 1 milligram, a range that is generally sufficient for all purposes. The combination given will permit any weight

being readily ascertained with the greatest ease, giving the least number of trials. The writer prefers, in the case of the small weights, to make them of aluminum wire, as the pieces are larger and more readily handled than those made of foil. For the milligram weights use No. 34 B. & S. gauge; for the tens of milligrams, use No. 28 or 30, and for the hundreds use No. 20 or 22. The larger weights are turned out of brass rods to the dimensions given below.

100 grams.	.5 grams = 500 milligrams.
50 "	.2 " = 200 " (2)
20 "	.1 " = 100 "
10 " (2)	.05 " = 50 "
5 "	.02 " = 20 "
2 " (2)	.01 " = 10 " (2)
1 "	.005 " = 5 "
	.002 " = 2 " (2)
	.001 " = 1 "

We will start with the milligram weight first. Adjust the balance accurately so that the needle swings to zero and stops there. Now place one of the borrowed milligram weights thereon and place on the other pan a short piece of the No. 34 wire and keep repeatedly trimming off the end with a sharp pair of scissors, or better yet, a sharp penknife, cutting down on to a piece of sheet zinc until it almost balances. Now remove the milligram weight and place on the pan holding the wire, which has been removed, and exactly balance it with small grains of sand. This balance must be absolutely exact or else the following process will be of little value.

When a balance has been affected, remove the milligram weight and replace it by the piece of wire just cut. Now with a very smooth cut file, that has been boiled in soda to remove the film of grease always present on new files, and thoroughly dried, carefully file off the end of the wire and try its weight until it exactly balances the sand on the opposite pan and the needle stops at zero when through swinging. This is known as the method of substitution, and is the most accurate method of weighing in the ordinary balance that is yet known. It insures that the com-

pared pieces shall be of exactly the same weight, regardless of the difference in the length of the two beam arms, however small this difference may be. This finishes the milligram weight. It should be particularly impressed that no weight should ever be touched by the fingers; always pick them up with a small pair of tweezers and if it is necessary to hold them in the fingers, do so with a piece of linen or silk between them and the skin. The skin is continually exuding moisture which will tarnish them.

Now place the two milligram weights on the pan together, and add more sand to the opposite pan until a balance is again secured. Cut off a piece of the wire slightly more than twice the length of the first piece and carefully adjust this by the method just given until it weighs exactly two milligrams. Then make another exactly like it. In the table given above those weights followed by the figure (2) are to be made in duplicate. We now have two two-milligram weights and a one milligram weight, the sum of which is five. Place the three on the pan together and balance with sand as before. Then cut another piece of wire as long as the three and adjust in a similar manner. If the work has been carefully performed the weights will be exact multiples of the milligram weight and the sum will be ten milligrams.

Now balance the ten milligrams against the ten milligram weight of the borrowed set and see that they balance perfectly. If they do not, go over the work carefully and see where the error lies. The ten milligram weight must balance these four weights just made, and the two 20's and 50 are made in exactly the same manner. All these wires should be bent into distinct shapes, the two's and 20 being bent into a V shape, the two arms indicating the denomination, and the five and 50 being bent into a pentagon or five sided figure.

The hundred milligram weights are made in a like manner, great care being taken to see that a strict multiple ratio is obtained in each. These fractional weights are the hardest to make and require considerable patience, but if well made are more than worth the time and trouble; and, furthermore, one has the knowledge that they are strictly accurate with each other, which is far

more important than the material of which they are made or their respective shapes.

The larger weights are all made of brass and lacquered, the lacquer being put on and baked before they are adjusted. It is common to make the little handles loose and screw them into the weights, which permits of the adjustment being made on them by filing and then, when they are screwed into place, no bare metal is exposed to the action of dampness or fumes. Below is given a table of sizes to which a set may be turned up and afterwards adjusted. Of course it will be impossible to give a size that will be exact in every case, since the density of the metal will vary greatly in different compositions. But the figures will be a guide, and if the knobs are made loose and screwed into the weight, very little adjusting will be necessary and that only on the in side. If the weights are light, small pieces of tin-foil can be put in the hole before the knob is screwed in. This loose knob is provided merely to allow the entire outer surface to be lacquered, which it could not be if the adjustment had to be made by filing metal from the outside.

If the above set is carefully and properly made it will be well worth the time and trouble and with care in handling will last a lifetime. Weights should never be handled with anything but a pair of tweezers and they had best be ivory tipped. Make a neat wooden block and drill holes in it that will just fit the weights and always keep them in their respective places. The value of the weight may be stamped on its knob and also beside the respective holes in the block. Only slight depressions need be made for the fractional weights and they should be kept covered with a strip of glass. A cover should be provided for the block to exclude dust.

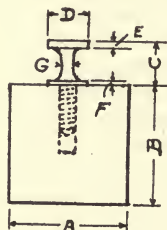

Value	A	B	C	D	E	F	G
1	13-64	9-64	17-64	5-32	3-64	1-64	3-64
2	15-64	5-16	15-64	11-64	3-64	1-64	3-64
5	33-64	3-8	1-4	3-16	3-64	1-64	1-16
10	7-16	33-64	17-64	7-32	1-16	1-32	1-16
20	9-16	19-32	1-4	1-4	1-16	1-32	1-16
50	25-32	25-32	1-4	1-4	1-16	1-32	1-16
100	11-16	55-64	1-4	5-16	1-16	1-32	1-16

HOW TO BUILD A SAILBOAT.

CARL H. CLARK.

III. Making the Frame.

The next things to be gotten out are the moulds, or temporary forms, upon which the boat is shaped. There is one of these for every cross section laid out on the floor. They are made to the inside line of the cross section, as already mentioned, since they fit inside of the plank. Numbers 2, 3, 4, 5 are made as shown in Fig. 7, being cut out to fit over the centre-board logs, while the others are made as in Fig. 8. For this purpose any kind of cheap stock may be used, but they must be well braced and strong, as they must

may be well fastened at the correct sheer height to make it easier to bend on the top strake of plank.

The moulds are set up in place on the keel at the proper points. It will be noticed that in the plan, the forward moulds are placed with their after faces on the mould line, and the after ones with their forward faces on the mould line. The reason for this is that the shape is desired at the mould point, and on account of the bevel, this would not be obtained otherwise. It will be necessary to bevel off the bottoms of the

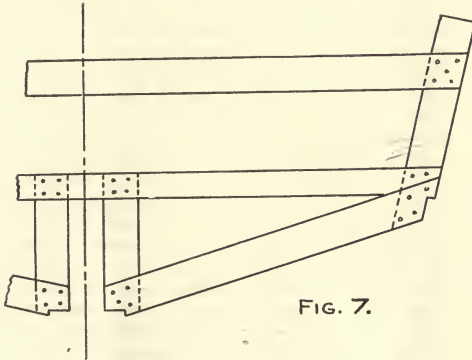

FIG. 7.

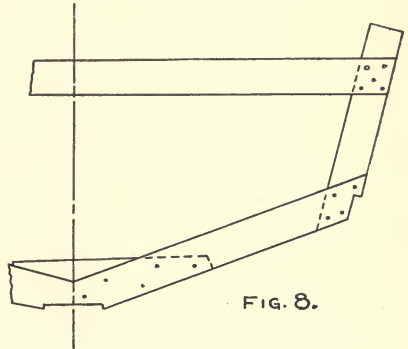

FIG. 8.

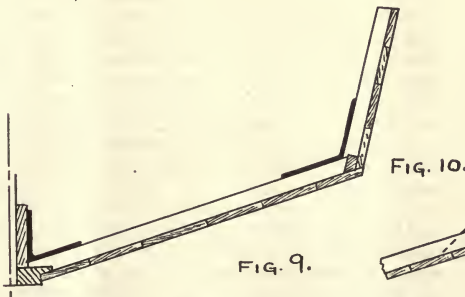

FIG. 9.

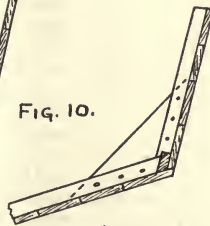

FIG. 10.

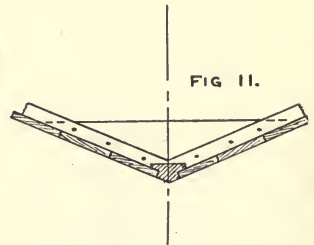

FIG. 11.

be able to stand a considerable amount of strain. They must also be an accurate reproduction of the lines on the floor, and be alike on both sides. The projecting side pieces are left to fasten braces to. The centre lines should be marked across the lower part and also across the top brace, for use in setting up. The notch in the corner is made to fit a $2\frac{1}{2}'' \times 1\frac{1}{2}''$ piece, which is to be later fitted into place and beveled off to make a smooth surface. The top cross brace

moulds somewhat to make them conform to the slant of the keel. They must be set up perfectly plumb or square with the W. L. and also square with the centre line fore and aft. The line already stretched from the middle of the stem to the middle of the sternboard, will help in setting them upright. A ribband $3''$ or $4''$ wide should be bent around near the tops and screwed to them and the stem and sternboard with screws to hold them in place. They may be test-

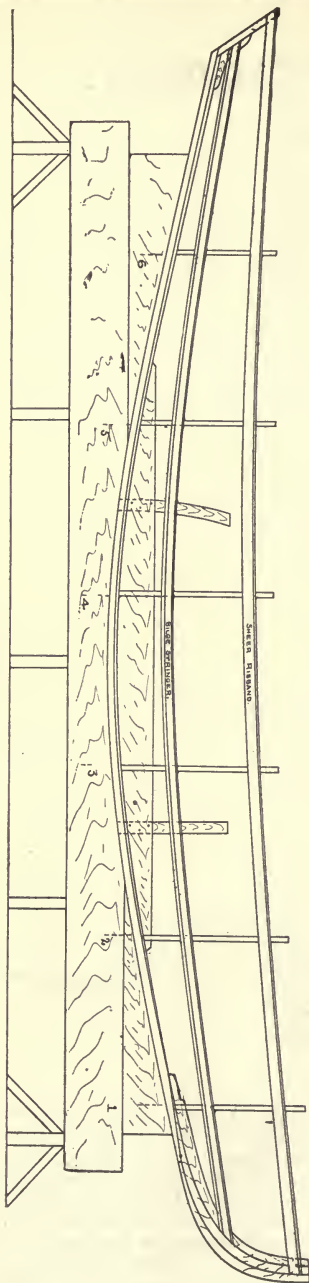

FIG. 12.

ed for squareness with the keel by measuring from the stem around this ribband to the mould, which should give equal lengths on both sides if the mould is square.

The center line marked on each cross piece will, when correctly set up, be directly under the line fore and aft. After the moulds are all adjusted, their fairness should be tested by bending a batten or thin board around them. If the board does not lie flat and even upon them the discrepancy should be noted and its cause looked up. It is always possible that small inaccuracies may occur during the process of transferring the shapes from the designer's drawing to the finished mould. Any small discrepancies may be left for correction until the moulds are ready to bevel.

The moulds are fastened temporarily to the keel by blocks of wood or small iron angle braces; the latter is best as fastening must be firm. When the moulds are all fairly in place they are braced diagonally from the braces overhead and also across the tops to each other and to the stern. In fitting the plank there is considerable strain brought upon the moulds and the bracing must be strong enough to stand it.

It has been noted that when the batten was laid on the moulds, it bore only on the corners. These corners must now be beveled off until it lies evenly on the surface, the whole thickness of the mould. The reason for placing the moulds as was done will now be seen, as the shape is only maintained at the edge nearer the middle of the boat; this edge being on the mould point. The corner piece $2\frac{3}{4}'' \times 1\frac{1}{4}''$ is bent around into the notches in each corner of the moulds. It must extend from the inside of the stem to the inside of the sternboard. At the stem it is let in a slight amount to give fastenings and on the sternboard it is fastened temporarily with small angle braces which are later to be replaced with knees. This piece is designed to afford fastening for the joint between the side and bottom boards. One face of it is now flush with the top side of the mould as shown in Fig. 9, and the lower edge must be beveled off to the line of the bottom face as shown by the dotted line. This angle changes all fore and aft and can only be gotten exactly at each mould, and between the moulds it must be cut by the eye. This allows the bottom plank to lie smoothly and be fastened to the bilge stringer.

The stringer is fastened temporarily to the moulds to hold it in place and keep it from springing out of the notches. The rabbet in the keel must now be cut out evenly all along to conform to the varying angle of the bottom. It must be so cut that when a piece of board is laid on the mould, it will fit squarely into the rabbet and make a neat joint. The angle changes at all points and between the moulds it must be trimmed until a piece of board laid on the bilge stringer will fit squarely into it. At the stem the rabbet can be fitted by bending a narrow piece of board around the moulds and cutting to the proper angle. This rabbet is to be carefully cut and fitted, as the

tightness of the garboard seam depends upon it. Before exerting any pressure upon the stem it should be braced sideways and have a brace under it extending to the floor to make sure that it is not forced out of line.

The planking should be either of pine, cedar, or cypress as is most convenient. It must be well seasoned and dry, in order not to check and shrink after being fastened into place. If possible, it should be in lengths long enough to extend the entire length of the boat without joints or butts, as this makes a smoother piece of work, besides being much easier. It should be noted that on account of the curvature of the side of the boat, the planks have a curve, or spiling as it is termed, which necessitates the board being considerably wider than the plank which is gotten out of it. The boards then, should be gotten as wide as is convenient, and planks worked out of them as wide as possible, up to about 6" wide. Too wide planks are not desirable, although they make fewer seams; the wide planks, however, are likely to check and split. It is not necessary that the plank should be entirely free from all knots, as small, tight knots are not at all a detriment, but rather add to the strength of the plank, and tend to prevent it from checking. Large, loose knots and weather checks, must however, be avoided. The plank should be $\frac{1}{2}$ " in thickness.

The planking may now be started. It is to be fitted on the topsides first, about four stakes being probably required. The top strake would best be fitted first, as it defines the sheer outline. The marks of the sheer are already on each mould and the stem, and it is only necessary to lay the plank on in place and mark it according to the marks on the moulds. With the batten, a fair line is drawn through these points. The width to be covered on each mould should be divided equally according to the number of plank it is intended to put on. The width of the top strake is then transferred from the moulds to the board, and a fair line struck through these points, thus outlining the lower edge of the plank.

The edges of the plank should be smooth and square. Where the plank joins the stem the curve can be obtained by clamping the plank on in place and marking across it to fit the rabbet. The end may then be allowed to spring out and be trimmed off to fit, the plank remaining in place. It may be sprung back and any further trimming noticed. It should be a neat fit for the rabbet and at the stern should project beyond. The plank for one side may be used as a pattern for the corresponding plank on the other side, thus saving all but the final trimming. The lower edge of one plank may also be used as a pattern for the top edge of the next plank below, and should be transferred to it before fastening in place. The top strake may now be fastened in place permanently. It should be clamped in place on the moulds and forced tightly into its place in the rabbet of the stem, where

it is secured with brass screws or galvanized boat nails. These fastenings should be countersunk by boring in about $\frac{1}{4}$ " deep with a bit large enough to take the head. The plank should also be fastened temporarily to each mould with long slender screws, working from the bow towards the stern. At the stern it should be fastened with brass screws, the same as at the stem. After fastening at the stern the plank should be cut off about 1" beyond and left rough. The second plank should be fitted in the same manner. The seam between planks should be close on the inside and just slightly open on the outside to allow the insertion of a thread of calking. These directions also apply to the succeeding strakes below.

The lowest strake of side planking should be fitted last. This strake extends to the lower edge of the bilge stringer and is beveled off to the same angle to take the bottom planking. This lowest strake, besides being fastened the same as the others is also fastened permanently to the bilge stringer throughout its whole length, either with brass screws, or galvanized boat nails driven through and clinched on the inside of the bilge stringer. If nails are used they should be clinched across the grain, and care taken not to split the bilge stringer in clinching. If it should be necessary to make a butt joint in any plank the ends should be brought together to a good fit and a block about 8" long fitted on the inside over the joint and the ends fastened to it with boat nails, clinched over. These joints must be so placed that the blocks will come between frames. There are three of the latter between each two moulds, 9" apart on centres. The proper position for the joint can thus be easily found.

The lower edge of the lower topside plank is to be beveled off to the same angle as the bilge stringer, so that the bottom plank will lie smoothly across both. This angle can be verified by bending a thin board over the moulds and trimming off to fit. The bottom plank is next in order. This plank is put on starting next to the keel and working outwards. The garboard strake or plank next to the keel is the first to be fitted. On account of the slope of the bottom, this plank will have a considerable amount of curvature and the "spiling" will require to be taken.

To obtain the spiling of the plank, a thin board with one straight edge is used. This board is laid on the moulds near the keel and clamped in place. The crossing of each mould is marked on the board and the distance measured from the edge of the board to the inside of the rabbet at each mould. The board is then transferred to the stock from which the plank is to be gotten out, and the same distances already measured, are laid off from the edge of the board. Through the points thus laid off a fair line is struck with the batten. The edge is trimmed to this line and is finally fitted by bending into place alongside the keel. These garboards must be very carefully fitted and lie fairly in the rabbet all fore and aft.

It is especially desirable that the garboard seam should be tight, as otherwise it is a source of much trouble and annoyance.

The upper edge of the garboard strake is left straight and at the bow is carried to meet the curve of the lower edge. This plank is fastened permanently to the back rabbet on the keel and stem and also to the sternboard if it extends so far. Owing to the width of the plank and its curvature it may taper out before reaching the sternboard, but it can be fastened securely to the keel. It is secured to the moulds with slender screws. The next, and the following planks, are cut in the same manner and fastened temporarily to the moulds with screws. The outer planks of the bottom will land across the bilge line, and are to be nailed to the bilge stringer and to the lower plank of the side. The bottom planking, where it extends beyond the bilge line, is now to be trimmed off even with the side planking and smoothed down. The bilge stringer, together with the side plank, give a double row of fastening and make a good tight joint. All the joints in the bottom should be close inside and slightly open on the outside. As fast as a plank is fitted on one side the corresponding plank on the other should be fitted, using the first as a pattern.

The frames are next to be put into place. They are of oak, or other hard wood, and are $1\frac{1}{2}'' \times 1\frac{1}{2}''$, and are put into the boat with the $1\frac{1}{2}''$ dimension vertical. As before stated, they are spaced 9'' on centres, or three between each two moulds. The frames are in two parts, one extending from the keel to the bilge stringer, and the other from the bilge stringer to the deck. The bottom frames are fitted between the keel and the bilge stringer, being notched out to fit the keel, and extending on to it as far as possible, to give a good fastening to it. A nail or two should be driven through the end of the frame into the keel, taking care not to split either the end of the frame or the back rabbet of the keel. The plank should be fastened to the frames with copper or galvanized boat nails. If the latter are used they should be bored for and clinched over across the grain of the frame, and carefully, to not split it. If copper nails are used they are cut off about $\frac{1}{4}''$ above the surface, a burr, or washer is slipped on and the nail is headed over, a heavy hammer or other weight being held against the head.

The copper nails are much to be preferred, as they draw the plank up very tight. Brass screws can be used for fastening the plank in place; in many instances they have given good satisfaction, but the writer does not recommend them for this purpose. The side frames extend from the upper edge of the bilge stringer to the top of the sheer strake already in place. This frame, being $1\frac{1}{2}''$ deep can be cut out to fit over the bilge stringer and make a clean corner with the bottom frame.

As the boat now stands she would be weak at the bilge and to remedy this, some sort of brace must be

fitted. A corner angle of galvanized iron $1\frac{1}{2}'' \times 3-16''$ is recommended as being very strong and taking up no room. It is fastened with rivets extending out through the plank. Fig. 9 shows the general idea of the frames and corner braces. If it is not desired to go to the expense of the corner braces, a corner piece of wood may be fitted as in Fig. 10, with the grain running as shown; a curved knee would, however, be better and would take up less space inside the boat. The tops of the side frames can be cut off even with the top of the upper strake of side planking. Towards the bow the bottom frames will require some fitting to make them conform to the twist in the surface. In fact, it will facilitate the fitting of knees and floors if all the frames are beveled so that they stand both plumb, and square with the centerline of the boat, and not square with the outline of the side.

Forward and aft of the centerboard box the frames, where they cross the keel are to have a floor, or cross piece fitted, to connect the two sides of the frame across the keel. These floors may be either of galvanized iron $1\frac{1}{2}'' \times 3-16''$ or natural crook knees set on the top of the floors, or a piece of oak about $1\frac{1}{4}'' \times 1\frac{1}{4}''$ may be steamed and bent into place across the keel and fastened through planking. A still simple way is to use a piece of board about $\frac{1}{4}''$ thick with the grain, as shown in Fig. 11, fitted at one side of the frame. It is notched down over the keel, and fastened to the frame and also to the plank independently of the frame. This method, although quite general, is not as good as others. The frames in the way of the centerboard box should have angle braces fitted into the corner and screwed to the centerboard logs.

As has been before noted, there are three frames between each two moulds. Those between the moulds should be fitted completely and all the fastenings driven and knees put into place. The moulds may now be removed and a frame put into the place of each, using the holes made for the screws, to take rivets, thus leaving fewer holes to be filled with putty. The ends of the planks, where they project beyond the sternboard, must be planed off smooth with its surface. The plank should not be planed on the outside until later. It will, however, be wise to give the planking a heavy coat of oil and then paint the inside with one coat. This will prevent its checking and shrinking during the remainder of the work. Fig. 12 shows the keel with the moulds set up in place, and the bilge stringer fitted ready for planking.

It is stated that during the recent conflagration at Baltimore, a watchman remained locked in a bank vault located in a building which was burned to the ground. It was the custom to lock the watchman in the vault Saturday night, with food sufficient to last till Monday. The fire prevented his release; when the debris was cool enough to admit of opening the vault on Tuesday, the watchman came out smiling.

PRINTING FOR BEGINNERS.

FREDERICK A. DRAPER.

V. Emptying the Composition Stick and Distribution.

When the composing stick has been filled it has to be emptied on to a galley. The illustration shows the position of the hands when doing this. The first efforts of the beginner should be made with the stick only partly filled, the full stick being attempted when experience has been gained. Also, in making the first trials, it is advisable to rest the stick upon a galley, as, in case of failure, the type will then be more easily held in place. In removing the type from the stick, the forefingers of each hand press firmly against a lead placed against the outside of the last line of type; the thumbs press against a lead or composing rule outside the first line of type; the two outer joints of the second fingers press against the ends of the lines, thus holding the type on all sides. The other fingers of each hand press against the stick to hold it while the type is removed through the open side of the stick and placed upon a galley.

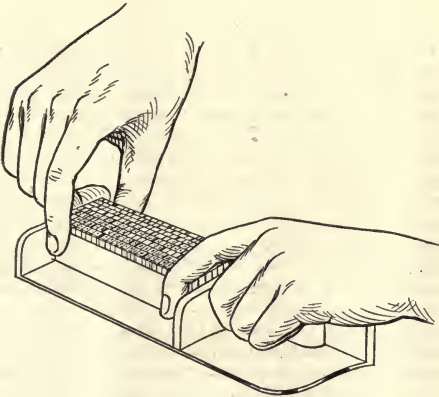

EMPTYING THE COMPOSING STICK.

As soon as the type is free of the stick, bend the wrists to bring the type matter to a vertical position, in which position it is carried to the galley. Care should be taken not to relax the pressure of the fingers at any time while the type is being removed or carried about. With very wide measure, the fore-fingers are applied to the type matter at such a distance from the ends of the line, as will give an even pressure to the whole length of lines, and it is frequently necessary to slide the type out of the stick on to a galley, so that,

in bringing it to a vertical position for carrying, this may be done with a quick movement, thus preventing the centre of any line from falling out.

When all the type matter is composed and assembled upon the galley, it is tied firmly with strong cotton twine as follows; Beginning at the free corner, wind the twine 10 or 12 times tightly around the type, having the turns overlap each other. A bodkin or the end of the composing rule is put down between the type and the several turns of twine, with the last turn on the inside; the end is then brought back on the outside of the bodkin or rule forming a loop. The bodkin or rule is held at an angle towards the right, and by pulling on the end of the twine the loop will work down the bodkin until it projects on the under side of the turns of twine.

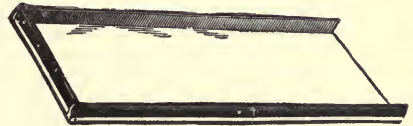

GALLEY.

Pulling the end of the loop will carry it back against the corner of the type where it will bind. This method of tying is secure, yet allows a quick removal of the twine by simply pulling on the free end. After fastening with the loop as above directed, press the twine down at the corners until about half way between the top and bottom, for, unless this be done, the tension of the twine is sufficient to cause it to slip upwards when moving the type from the galley, and perhaps cause several lines at each end to "pi."



HAND ROLLER.

It is customary, after tying up the type, to take one or more proofs. If a proof press is available, the type is placed thereon; inked with a hand roller, a piece of paper of suitable size to give ample margins for corrections, is laid upon the type and an impression taken. As many amateurs are not provided with a proof press, the following method will enable good proofs to be

secured, if care is used in taking them. Ink is placed upon a slab of marble (tiles about one foot square answer admirably for a small shop), a hand roller is run over it several times to distribute the ink evenly; the type is then inked with a light and even pressure of the roller; the paper is moistened on one side with a fairly moist sponge, the dry side placed upon the type, and firmly and evenly impressed upon the type with a proof-planer, upon the top of which firm, but

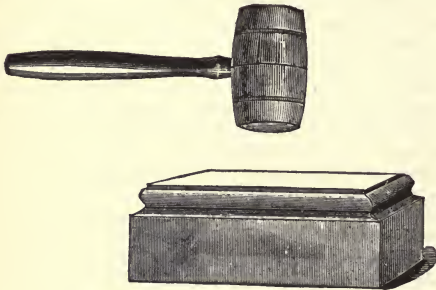

MALLET AND PLANER.

not very heavy blows are given with a mallet. The paper is then removed by taking hold of one edge or end and pulling in the direction of the opposite edge or end. A little practice will be necessary before this can be well done, the necessary requirements being; a hand roller in good condition, the right amount of ink evenly distributed on the stone and type, paper of good surface and strength and properly moistened.

After taking a proof, the ink remaining upon the type is washed off with benzine applied with a long handled bristle brush. The brush is saturated with the benzine and the type scrubbed until the ink is thoroughly removed. Electrotypes and process cuts are more easily cleaned by using cotton waste, wet with the benzine. It is quite essential to thoroughly clean the type, as if this is not done, the ink will settle around the joints and there harden, giving an uneven surface to the sides of the type, and causing them to stand unevenly. Justifying the lines and good



press-work will thus be made a difficult matter to obtain. After printing large editions, and following continued use of type, it is also customary to wash with a solution of lye, this being more efficient in removing ink than is benzine. It should be a rule rigidly observed that the type be kept as clean as possible. The benzine must be stored in "Safety" cans, this being a regulation of insurance companies, and only a small quantity can be kept on hand. A one quart can is a good size, this quantity costing about ten cents, and lasting for some time in a small shop.

Omitting for the present the locking up the type in the chase and the press-work, and assuming that these

have been completed and the type again in the galley, the next operation is that of distributing it into the case. The type is first wet down with water applied with a sponge. This has the effect of holding the type together, and yet allows of easy separation when throwing in. A quantity of type matter equal to about a stickful is taken up, as previously explained for emptying the stick, and supported in the left hand as shown in the illustration. The second, third and little fingers are turned inward forming a support for the type, which is steadied at the back by the fore-finger and on the end by the thumb. As with composition, the nicks are uppermost, the letters being read upside down, and the end of the line to the right.

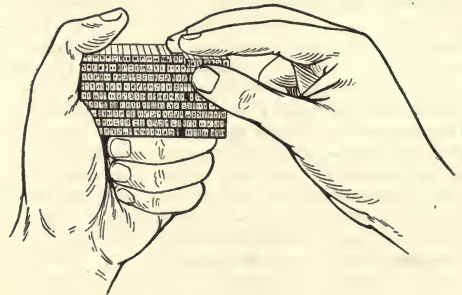

DISTRIBUTION TYPE.

With the end of the second finger of the right hand, push the end word a little to the front, grasp it between the fore-finger and the thumb, having by this time read it, and drop each letter in the proper box. This release of each letter is affected by pressure of the finger and thumb, assisted a little by the second finger. The thin letters will cause most trouble at first, care being necessary to hold a thin one after dropping a thick one, but the ability to do this will be readily acquired with practice. Care must also be used with the spaces, the different sizes being kept separate. It is an easy matter to drop them all into the box at the lower edge of the case, but this only means trouble, and loss of time when composition is again done from that case, and nothing is gained by lack of care in this matter. Extra characters should also be carefully laid in an extra stick or other receptacle, and thence in the proper case, to avoid possible loss or mislaying them where they cannot readily be found when wanted.

It will be noted, from what has here been said that an orderly method of work and arrangement of materials is absolutely necessary to proper and economical work in a printing office, and the more this idea is followed the better will be the results and greater the profits.

Those who have already secured Amateur Lathes, state they are more than pleased with them.

A MODEL STEAMBOAT.

CARL H. CLARK.

III. The Boiler.

The boiler here described is of the type known as the Scotch cylinder. The shell is 6" diameter and 8" long. It is rolled up from a sheet of copper 8" wide, 19 $\frac{1}{2}$ " long and 3-32" thick. It is to be rolled up exactly circular and riveted together with a lap of $\frac{1}{4}$ ". The rivets should be in a double row and zig-zag spaced. They should be of copper 5-32" diameter, with round heads and should be spaced quite closely together. The riveting must be carefully done, and then riveted and worked up into as much of a head as possible, to draw the ends of the sheet tightly together. As this riveting is a matter requiring some skill it will be well for the amateur to sweat a layer of solder along edge of the joint both inside and outside after riveting to insure thickness.

laying the blank upon it and hammering the edge lightly all around. The effect of this hammering will finally be to shrink the metal and form the flange. The flanged hole is formed in the same manner by hammering the edge over into a smooth round hole. The edges of the flange are then trimmed off to $\frac{1}{4}$ " wide. This flanging is a nice piece of work and requires much care and patience. The flanges must be round and at right angles to the surface of the plate in order not to warp the shell when riveted together.

The front head should have reinforcing plates at the points shown, for the gauge glass, and below the furnace as shown by the dotted circle about $\frac{1}{2}$ " diameter. There are 7 tubes on each side, 9-16" outside diameter, for which the holes should be now drilled; they should

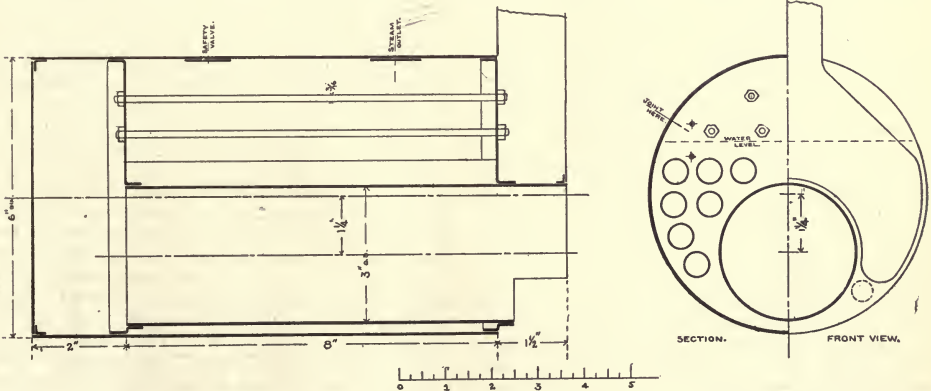

It may be possible to procure a piece of seamless drawn copper or brass pipe of the required diameter and about 5-64" thick. Brazed pipe must not be used as it is not strong enough. The openings in the shell are, one for the safety valve and one for the steam outlet. A reinforcing piece 1-16" thick should be riveted on the shell under each. The holes are to be drilled later. The furnace is a tube 3" diameter, 1-16" thick and 9 $\frac{1}{2}$ " long, with its outer end cut away as shown. Seamless drawn tube must be used for this also.

The heads are 7-64" thick, with the outer edge flanged to fit inside the shell and a flanged hole to fit over the furnace. About $\frac{1}{4}$ " should be allowed for flanging and it is accomplished by cutting out a circle of hard wood of the size of the inside of the flange,

be spaced alike on each head. The holes in the back head should be a trifle smaller than the tube and those in the front head a trifle larger than it; 3-16" holes for the stays are also to be drilled as shown. They should divide up the space between the tubes and shell so that each will bear as near as possible its share of the load produced by the steam pressure on the front head.

In setting up the boiler, the front head is first inserted and riveted in place. The position of the joint in the shell in regard to the furnace should be noted; and the head placed accordingly. The furnace is next adjusted to the opening in the back head and riveted up. The back head and furnace are then inserted from the back, the furnace projecting through

the front head the proper amount. The furnace mouth is next riveted and lastly the back head. The rivets for this purpose are about 5-32" diameter, and are spaced about 5-8" on centres in a single row. The holes should be drilled through both pieces at the same time to be sure of a good bearing, and care must be taken that no chips or filings are between the bearing surfaces to prevent a good bearing.

As the foundation of these joints, to be perfectly steam tight, is a very nice piece of work, it may be well for the amateur to solder all the joints to insure that they shall be tight. It must be borne in mind that no dependence is to be placed upon the solder for strength as this must be supplied by the rivets. The tubes are 9-16" outside diameter, about 1-32" thick, and long enough to extend from outside to outside of heads, and leave about 1/4" on each end for heading over. The back end of the tube is to be filed slightly until it just enters the hole in the back head, and the front end of the tube is to be expanded somewhat by driving in a taper plug until it is a close fit for the hole in the front head. The tubes will pass easily through the hole in the front head, and are driven up to a good bearing making a tight joint with both heads. With a ball pine hammer the projecting end of the tube is now headed over. The ends of the tubes are cleaned and a ring of solder sweated into the corner around the ends of each tube to insure tightness.

The stays are 3-16" diameter, spaced as shown. If possible the ends of the stay, which are threaded, should be upset so as to make the diameter at the bottom of the thread 3-16" and thus preserve the full strength of the rod. The nuts are screwed on to give a slight pressure without distorting the sheets. Under each nut a round washer 1/4" diameter and 1-16" thick is to be placed to further support the sheet. All the stays should have as near as possible the same tension. After they are adjusted the end of the thread projecting through the nut is riveted over and solder sweated around the nut and washer to make it tight. The back sheet is of brass 1-16" thick and a loose fit for the back of the shell. It is not necessary that this should make a tight joint, as it merely guides the flame around through the tubes and forms a combustion chamber. It is held in place by eight angle lugs screwed to it and riveted to the shell. The inside surface of the back sheet is to be covered with asbestos, as any heat passing through this sheet is a loss. This sheet should be so fastened in place as to be removable, en desired, to repair leaks or for other purposes.

The up take, or smoke box leading to the funnel is formed of thin iron or brass sheets of the shape shown to fit over the ends of the tubes, and rest on the projecting end of the furnace tube. The upper end must be worked into the round of the funnel which is about 1 1/4" in diameter. The front is held by a small angle fastened to the top of the furnace. It should be removable to get at the tube ends. When

the boiler is complete it should be tested. A hole should be drilled in position for the steam outlet and connection made to a small force pump. The boiler is filled with water, and pressure is put upon it with the pump. Any leak will be seen by the water coming out. In place of a force pump, a bicycle pump can be used if desired.

The boiler is designed to carry up to 50 lbs. per sq. inch, and should be tested to 75 lbs. per sq. inch. The boiler is to be supported in the boat by two saddles curved on the upper side to fit the boiler and on the lower side to fit the hull. The various fittings, safety valve pump, etc., will be described in the next issue.

MODERN RUHMKORFF COILS.

The modern American type of Ruhmkorff transformer, or induction coil, is one of the most important pieces of electrical apparatus to be found in an experimental laboratory. It differs so materially in efficiency from the old fashion types of foreign construction, that to construct a coil along the lines of a decade ago, would be at a considerable waste of time and material in the winding.

† The one to six inch spark coils, as constructed by the makers of today, are the result of delicate calculations made in connection with the construction of thousands of coils to be used in "wireless" work, and gas engine operation, each point of detail being perfected by comparative experiment in the mutual relation of one part of the coil to the other.

‡ It is obvious that in these numerous tests, many old-time theories regarding transformation have been eliminated, partly because of proven inaccuracies, and also because commercial competition and the increasing demand for coils to meet certain requirements have brought forth winding machines for bobbins of standard dimensions and specifications securing the greatest efficiency with a minimum of time and labor.

The fundamental principles of the conversion of the electric current are now so well known that an extended description of the simpler forms will not here be given. Old time builders theoretically calculated, disregarding wire resistance and core loss, (hysteresis) an objectionable property which the iron core has, when in action, of resisting the magnetizing current, that the Voltage times Amperage in the primary coil equal V times A in the secondary coil. From this it was deduced that any variation in the number of turns in either winding produced a change in the relation of Volts and Amperes in the primary to that of the secondary coil, all of which is eminently true. But much, however, has been learned by recent work regarding the adjustment of the primary to the work required, the insulation of the windings, and the proper disposition of the secondary bobbins upon the

primary, and the construction of the current break or "interrupter".

This modern research has opened new possibilities, and today the coil makers have no difficulty in constructing sectioned coils to give any desired spark, (20 inches if necessary), wound in perfect layers with suitably prepared insulation between each layer.

Obviously, between contiguous "turns" in the secondary coil there is practically no potential difference and little tendency to discharge. With sufficient layers of dielectric substance between each layer of wire the chance of injury to the windings is very slight, this insulation being sufficient to withstand any potential which can be derived from the magnetic influence of the primary coil.

When the secondary is formed of independent sections, which are wound in such directions as to permit of opposite terminals being connected together, the potential near the primary becomes little more than zero; the coil is then able to withstand an enormous strain, and old time difficulties of secondary discharging into the primary are no longer troublesome.

In the construction of secondaries, the amateur becomes puzzled in his calculations, both as to the amount of fine wire to be used to obtain a certain spark, and the proper disposition of this wire in turns upon the primary, for it is the turns which count. Miles of magnet wire indiscreetly placed in the secondary, would oppose the influences of the magnetic field, and not-withstanding how efficiently the rest of the coil might be constructed, the resulting spark would not come up to the expected length and "fatness"; in fact there are in use today, commercially, many coils wound in such a manner that one third of the wire is worthless, or in other words, had this wire been properly adapted to the primary the results would have been one third greater.

In considering a practical coil, we first enter into the theories of a most unique force of nature,—magnetism. We learn that a core of annealed iron wires, of a prescribed length and diameter, has a limit in magnetic saturation, and when that point is reached we may estimate what may be expected from a secondary bobbin properly placed upon the core. For this core, when magnetised, will influence a certain cross-section in a secondary winding, and while the ratio of cross-section of the core to that of the secondary may vary in the plotting of magnetic curves for coils of low and high frequencies, a well accepted rule is to limit the secondary diameter to about twice that of the primary, these calculations being determined by tests made in the construction of many small coils now in general use.

In "filling" and "emptying" a primary winding with electric current by means of a vibrator, or interrupter, we note a certain relation between capacity and frequency. We note that a large secondary containing many turns of wire is often poorly adapted to high frequency, while a smaller one having less turns,

sacrifices potential and gains quicker discharge. We are led to appreciate, therefore, that the best interrupter for the amateur's first experiments is one adjustable within reasonable limits, either by weights fastened to the free end of the vibrator, or by varying the length of the vibrator at will.

A condenser (the capacity of which is governed by the frequency and strength of primary battery) is used with this type of interrupter.

Having decided upon the size of the core, and the amount of primary current at one's disposal, one enters into the calculation of the size of wire to be used in the primary. The gauges of wire usually run from No. 14 for large coils to No. 18 for small ones.

As the primary resistance is low, and the number of layers usually two, the most efficient winding for getting the best results out of the core, with a specified frequency of interruption, is easily decided by experiment. The magnetic influence of a primary core may be readily tested with iron filings, or by suspended needles placed within reach of the lines of force.

Tests have proven that the most vigorous lines of force play near the ends of the primary core, while at the middle the magnetic curve drops close to the core. Hence we are led to distribute the wire of the secondary where the influence is the strongest.

And if the secondary is wound in two separate bobbins, each bobbin being wound to twice the primary diameter;—each bobbin being as long as its diameter and each bobbin placed one-half its length from the end of the primary core, the core being of such a length that the space between the bobbins will equal about one-half the diameter of the secondary bobbin, and with the insulation in all parts of the secondary perfected, as previously noted in this article, the result should be a coil suited to all the experimental needs of the amateur electrician.

It is, therefore, considerable of a question, in view of the facts above stated, whether the amateur of limited experience should attempt the making of a secondary coil, other than of very small size and capacity, and this is especially true if a secondary adapted to his needs can be purchased at little or no increase over the cost of material. As experience is gained, and a study of coil windings and their action becomes desirable, then constructive work with secondary coils can be taken up to good advantage.

Mr. Blaikie declares that if every schoolhouse had a simple running track just around it or in its basement, asphalted like those in some of the later up-to-date schools in New York City, and, if every pupil ran there at a moderate pace for five minutes each day, it would do more for the American lungs and American health than all the other minutes in the day put together now do.

JUNIOR DEPARTMENT

For the Instruction and Information of Younger Readers.

ELEMENTARY MECHANICS.

F. A. COOLIDGE.

II. Friction.

Before proceeding further with the study of machines we must see what influence friction has upon their action, and what means must be employed to make it as small as possible. Friction may be defined as the resistance a moving body meets as it passes over the surface of another body. It is largely due to the roughness of the surfaces in contact, but some of it is due to adhesion. In the study of the levers no mention was made of friction, as it played so little a part in their action; but in the other machines we must know how much of the force employed in moving a body is lost through the rubbing of the surface in contact. Machinery must be made with a view either to make use of friction, or to remove its influence so that as little of the force as possible shall be lost.

For the simple experiments we are to perform we need a spring balance with which to measure every force exerted. One graduated from $\frac{1}{2}$ ounce to 64 ounces can be bought for 35 or 40 cents. As this is to be used for horizontal forces, a rest to hold it should be made from a block 2" x 3" x 4". A hole 1 $\frac{1}{2}$ " in diam-



Fig. 4.

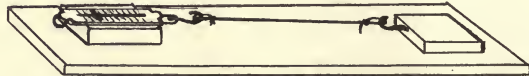

Fig. 5.

eter should be bored through the block lengthwise and the block then sawed lengthwise. After we have smoothed down the sharp edges the rest for our balance will be 4" long, 2" wide, 1 $\frac{1}{2}$ " high, and it will have a trough running lengthwise to hold the spring balance. An sectional view is seen in Fig. 6. Next we will take an inch board 4' long, 6" wide and plane it as smooth as possible on one face, leaving the other face rough. We will call this board *A*. A block *B* 3" x 4" x 1" with a strip $\frac{1}{4}$ " x $\frac{1}{4}$ " fastened around the edge of one side, and fitted with a screw hook at one end, completes the apparatus needed. See Fig. II.

EXPERIMENT VI.

Place block *B* upon the rougher surface of board *A* and connect the hook of the block with the hook of the balance by means of a thread. Draw the block along the board several times noticing carefully the force used each time. Do not record the force necessary to start the block, but observe that it is always more than the force required to keep it in motion

after it is once started. The average of six or eight trials will give us the force needed to pull the block along the board. Weigh the block carefully and divide the force used by the weight moved. The quotient $F \div W$ is called the coefficient of friction.

EXPERIMENT VII.

Repeat experiment, I using the smooth face of the board. We shall find the force needed to move the block smaller than before. By making the surface in contact as smooth as possible, much of the friction is removed. Calculate as in experiment VI the coefficient of friction, which should be less than .4.

EXPERIMENT VIII.

The block *B* has a base 3" x 4" or 12 square inches. One of its sides is 4" x 1 $\frac{1}{4}$ " or 5 square inches. Pull the block *B*, resting on its side, along the board *A* and find, as before, the average of six or eight trials. We ought to get the same results as in experiment VII, and should see the truth of the next law of friction, viz., that the size of the surfaces in contact does not determine the amount of friction, although we might expect the friction would be more when the larger faces are touching each other.

EXPERIMENT IX.

We will now make a series of trials in which block *B*

shall carry different weights and exert an increasing pressure upon the board *A*. We can again use the weights made for the experiments in levers, or, if we have not made these, we must provide a number of small tin boxes and by filling them to different depths with sand we can obtain weights that will answer our purpose very well. A careful record of all our experiments, with a statement of the results obtained and inferences made, will make the value of these experiments much greater. Let us arrange the experiment in tabular form.

Weight moved	Force used	$F \div W =$	coefficient of Friction.
8 oz.	2 oz.	$2 \div 8 =$.25
16 oz.
32 oz.
48 oz.
64 oz.

The figures under force and coefficient are possible figures. In each case the average of several trials

ould be made. In studying the figures obtained it is plainly seen that the force increases almost exactly in proportion to the weight, also that $F \div W$ is the same for the five trials. These verify the laws that friction increases with the weight and that for two given substances the coefficient is the same. That other bodies will have a different coefficient may be seen by repeating experiment VII using a pane of glass instead of board A. Another way of reducing friction is the substitution of rolling motion for sliding motion. For this purpose three good, smooth lead pencils may be used under block B.

EXPERIMENT X.

Lay the pencils across board A with the block B resting on them. Compare the force needed to move B over these rollers with the force used in making it slide along the board. The force seems ridiculously small. Calculate the coefficient. Can it be a fraction so small? Repeat with other weights and calculate as before.

From the experiments performed we see why so much pains is taken in making a railroad, and we now see how it is possible for a force of eight or ten pounds to move a ton weight. Now we know why the axles and bearings of wagons and machinery are made so smooth, and why oil, grease, and graphite are used so freely. The ball bearings of bicycles and other machines seem to be the height of man's achievements in preventing wasted work.

We must look for a moment at the other side of the question and see mischief would result if there were none. Walking would be impossible. Cars and wagons would not move, or the wheels would turn but no advancement be made. We oil the axles and sand the tracks; we oil the bearings of machinery to prevent and put something on the belt to create friction. In some cases, we need more than we have, and in others we try to remove what we do not need. In conclusion, we must acknowledge friction useful in its place, but worse then useless where we do not need it.

ELECTRICITY BY EXPERIMENT.

I. Magnets.

Faraday, the great electrician, was not satisfied to read of new experiments, but made a practice of working them out for himself, that he might observe everything connected with the processes, and learn from personal observation the phenomena peculiar thereto. The example of this illustrious man can well be followed, as far as possible, by all who desire to study Electricity and Magnetism, and it will be the purpose of these chapters to so present the subjects by means of simple and characteristic experiments, that anyone may acquire an elementary knowledge which will serve as an excellent foundation for more advanced work.

With this brief statement of our aims, we will consider the subject of *Magnets*. This name is applied to any body which has the property of attracting iron. In the natural form it was known to the ancients, being found at Magnesia, in Asia Minor, hence the name. It is also found in Spain, Sweden, Arkansas and other parts of the world. In its natural state it is a heavy dark brown or black stone. Its property of attracting iron is best studied by bringing it in contact with iron filings, and this will be our first experiment.

EXPERIMENT 1.

Procure a small quantity of clean iron filings from a machine shop, or make them by filing a piece of cast iron with a coarse file. Lay a piece of *Magnetite*, (magnetic oxide of iron) upon the filings, turning it over so that all sides and the ends will come in contact with the filings. Upon lifting, we observe that the filings are so strongly attracted at the end, that a considerable quantity is retained thereon, but that at the centre no such attractive force seems to exist.

There is another property peculiarity to this stone, which was discovered by the Chinese; if suspended by a string it will turn so as to point north and south hence the name *Lodestone*, or leading stone. In the navigation of ships this was the compass of earlier days.

EXPERIMENT 2.

Suspend a piece of Lodestone by a strand of untwisted silk and observe the tendency to turn as stated.

The natural magnet possesses the property of imparting magnetism to pieces of hard iron (steel), making of them *artificial magnets*.

EXPERIMENT 3.

Take a piece of steel (large sewing needle or knitting needle) and rub one end from the centre with one end of piece of Lodestone; rub the other end from the centre with the other end of the ore. See if the piece of steel will attract iron filings, and at what points the attractive force is greatest. Suspend at the centre with stirrups made of small copper wire and held by a strand of untwisted silk thread, and see if it will turn and point north and south.

This artificial magnet is a simple form of the mariner's compass, the latter being more strongly magnetized, and suspended in a more sensitive and usable way. The ends of a magnet, (either natural or artificial) are called the *Poles*; that pointing towards the North being generally termed the North pole, and the other the South pole. All magnets will have both poles in some form, the attractive force of the earth acting upon each, being about equal. The reason why the magnet points North and South is that the earth is a great magnet with magnetic poles, which are not the same, however, as the geographical poles. Why the suspended magnet turned will now be learned in

EXPERIMENT 4.

Suspend the bar magnet as in the previous experiment, and note the North seeking end or pole. Holding in the hand a similar bar or horseshoe magnet, bring the N pole, which has been marked to indicate it, near the N pole of the suspended magnet. The N

pole of the latter is repelled by the N pole of the magnet held in the hand; if the other or S pole is held near the N pole of the suspended magnet the two are attracted towards each other. After trying each pole of each magnet, we will learn that;—*Like poles repel, and unlike poles attract each other.* From this we learn that there must be two kinds of magnetism; that which is attracted towards the N magnetic and that which is attracted towards the S magnetic pole. From what we have already learned of the attractive and repelling force of like and unlike poles, it follows that the magnetism of the earth's poles must be of the opposite kind to those of the magnets. The magnetism of the earth's N pole must be S magnetism, the N magnetism being at the South magnetic pole.

It has been already stated that, with the bar magnets used in the preceding experiments, the earth's magnetic force affected the poles of the magnet equally. The following experiment will show that this is true.

EXPERIMENT 5.

Magnetize a large sewing needle. Place same on a piece of thin cork, along the top of which has been cut a groove for holding the needle in position. Place in the centre of a shallow dish of water. If the needle has been sufficiently magnetized, it will slowly turn and point North and South, but with no tendency to move towards either of these points.

As permanent bar magnets will be necessary to other experiments to follow, the following directions for making a pair are given at this time, that they may be used in experiments. The principles governing the method used will be considered at another time.

Obtain two pieces of tool steel, 4" long, $\frac{1}{2}$ " wide and $\frac{1}{8}$ " thick, and smooth all sides and ends with a fine file and emery cloth; wind one the full length with a close coil of magnet wire, about No. 16 gauge. Connect the ends of the wire coil with a battery of several dry cells connected in multiple, i. e., the carbon or centre terminals connected to one wire, and the zinc or outer terminals to another wire. Take careful note of which way of the piece of steel is contained in the coil, the way the coil turns around the steel, and the ends of the coil connected to the carbon and zinc terminals of the battery. Allow the current to flow around the coil for a few minutes, lightly tapping the end of the steel with a small hammer. Remove the piece of steel and it will be found strongly magnetized. Test with a suspended bar magnet to determine the polarity of the ends, marking the N pole with a slight scratch across one side near the end. Mark the other piece of steel with a similar scratch, place in the coil and magnetize so as to have that end the N pole. Reversing the connections with the battery, or the direction of the winding of coil around the piece of steel will reverse the polarity of the magnet.

For storing bar magnets when not in use, make a block of wood long and wide enough to have a dividing strip of wood $\frac{1}{2}$ " wide between the magnets, and at

each end a "keeper" made of soft iron. These should always be placed against the poles of the magnets, and will prevent them from losing the magnetism.

CORRESPONDENCE.

No. 74. CHICAGO, ILL., Feb. 18, 1904.

Being a reader of your paper, "AMATEUR WORK" I would like to ask how a storage battery can be sealed up so as to prevent it from corroding at the connections. I have made and used quite a number and understand them fairly well, but cannot overcome this fault. V. A. S.

The creeping of salts from the electrolyte is a fault common to about all form of batteries. The best method of preventing this is to coat the exposed parts of the elements with melted paraffin. The other way is to adopt a form which will permit of sealing with pitch, but this is a difficult matter to do successfully.

No. 75. CHICAGO, ILL., Feb. 22, 1904.

On Page 99, Amateur Work for Feb. 1904, it reads;—"Lay out a centre line, passing through the centres of the end edges and another at right angles thereto at the centres. Then lay off the three holes for the knife edges so that the upper edge of the holes at the ends just touch the line and the bottom edge of the centre hole does the same". There is a line on the beam in the drawing with the holes touching it but it seems to be about 1-32 inches above the centre of the beam, the 1-16 inches shown appearing to be at the centre. Where are the holes located with reference to the horizontal centre of the beam? Would a line touching the edges of all the knives be in the centre "up and down" of the beam? H. H. B.

The upper side of the holes for the end knife edges, and the lower edge of the hole for the middle knife edge lie on one straight line which is 1-32 inch above the centre line of the beam. In all balances the knife edges must lie in the same plane.

No. 76. ANDERSON, IND. Feb. 22, 1904.

Please send me instructions for finding the amount and size of wire to be used on dynamo the size and shape of the accompanying cut not shown, to produce 110 volts and 4 amperes; if it can be wound for that. If not, the highest E. M. F. possible. J. W. J.

This dynamo cannot be wound for four amperes at 110 volts. It might give two amperes at that pressure, or four amperes at 55 volts. There are not enough slots, even with two coils in each slot, for so high a voltage. For 110 volts there should be at least 20 slots. If that number is used they would be 5-16 inch diameter. Armature should be wound with 20 coils of No. 24 double cotton covered wire, 16 turns per coil, two coils or parts of two coils in each slot. This would require about 300 feet of wire. The field magnet core should be at least 2 inches in diameter instead of 1-8 inches. This could be wound with 25 layers of No. 30 single or double cotton covered wire. This would require about 3000 feet. The pole pieces come too close to each other; 1 inch or 1-4 inch would be much better than 1-2 inch as shown in the drawing. Speed, 2000 R. P. M.

No. 77. CHARLESTOWN, MASS. Feb. 20, 1904.

I have a few questions to ask and would be greatly obliged if you will answer them. A. About what would be the cost of two ebomite disks, about 19 inches in diameter and 1-8 inch thick. Where is a good place to buy ebomite? B. Would it be convenient for you to give directions for making a 1-4 H. P. air engine in one of your future numbers? What would be the cost of materials? What is the cost of running a hot air engine as compared with a steam engine? C. What does aluminum cost per pound and where may it be bought? R. C. H.

Two discs of hard black fibre would weigh about three pounds and cost about 50 cents per pound. I think you can obtain them from Chandler & Farquhar Co., 34 Federal St., Boston, Mass.

A hot air engine of about 1-8 H. P. is in this issue. From it you can get a general idea of size and shape for a large one. The author is arranging to supply castings which can be finished to any desired extent, the price of which has not yet been determined. The cost of sheet aluminum depends upon the gauge; it can be purchased of A. J. Wilkinson & Co. 180 Washington St.

AMATEUR WORK

A MONTHLY MAGAZINE OF THE USEFUL ARTS AND SCIENCES

Vol. III. No. 6.

BOSTON, APRIL, 1904.

One Dollar a Year.

A SPECTROSCOPE.

A. ROTHWELL.

The high price of many of the required instruments prevents amateurs and students from purchasing them, and entering into the study of the natural sciences, much valuable knowledge and many a pleasant entertainment is lost to those who would, but for the above reason, gladly persevere in scientific studies. The spectroscope affords a means of examining the rays of light emitted from any source and determining their composition. Those who have not seen the beautiful prismatic band from white light will marvel at its beauty and purity of color, ranging from the red to the violet. It will well repay such to make the simple and inexpensive spectroscope here described.

Procure a piece of zinc, 14 or 16 gauge, 12" long and 3" wide. Cut this into pieces to make a prism as shown in Fig. 1; that is, cut three pieces 3" x 2 1/2". In two of these cut out a space in the centre 1 3/4" x 3/4" as shown in Fig. 1. Solder the pieces together so that the base will form a true equilateral triangle, using a triangular piece of wood to assist in obtaining the correct shape. Then fit in the top and bottom triangular pieces, the top having a hole bored through and over this a threaded 1/2" nut is soldered. Fig. 1 shows the appearance of finished prism. Black the inside with thin glue to which a little lamp black has been added; this is to prevent reflections.

Take a piece of sandpaper upon a flat surface, and rub the sides of the prism containing the openings until they are flat, then rough up with the corner of a file, this is to give the glue a better opportunity to stick. Take two pieces of flat glass, 16 ounce English or German plate, free

from scratches, and glue on the sides containing the openings. These pieces of glass should be 1/8" smaller all around than the sides of the prism. See that sufficient glue is put on to make a thorough contact, using care to keep the centre clean and free from glue. A little glycerine or molasses may be added to the glue to keep it from drying too brittle. Set away to dry, which will take about a week. When thoroughly dry, fill the inside of the prism nearly full with a solution of bisulphide of carbon, leaving an air space for expansion. Put in a machine screw, which has been covered with glue; allow it to set. As bisulphite of carbon has a very disagreeable odor and is very inflammable, the filling of the prism should be done in the open air and away from any flame.

This being done, take two mailing tubes from 1" to 1 1/2" diameter according to diameter of lenses used, but of the size to telescope, one into the other. If they do not fit snugly, paper may be wound around the outside of the smaller one until it slides easily, yet must remain stationary where placed. The next requirement will be the end of the tube that carries the slot, as shown in Figs. 2 and 3; the former being a section on line *a a* in Fig. 3 which is a front view. A circular piece of wood 1/4" thick, with a hole cut through 5/8" high and 3/8" wide, is then glued inside the inner tube so as to be at right angles to the tube. Any cutting of the mailing tubes may be done with a fine jeweller's saw in a square mitre box. The ends can be smoothed with sandpaper, the tube being held in a vertical position. The other arrangement is made out of cigar box; Fig. 4, 5, and 6 shows the arrangement to better advantage

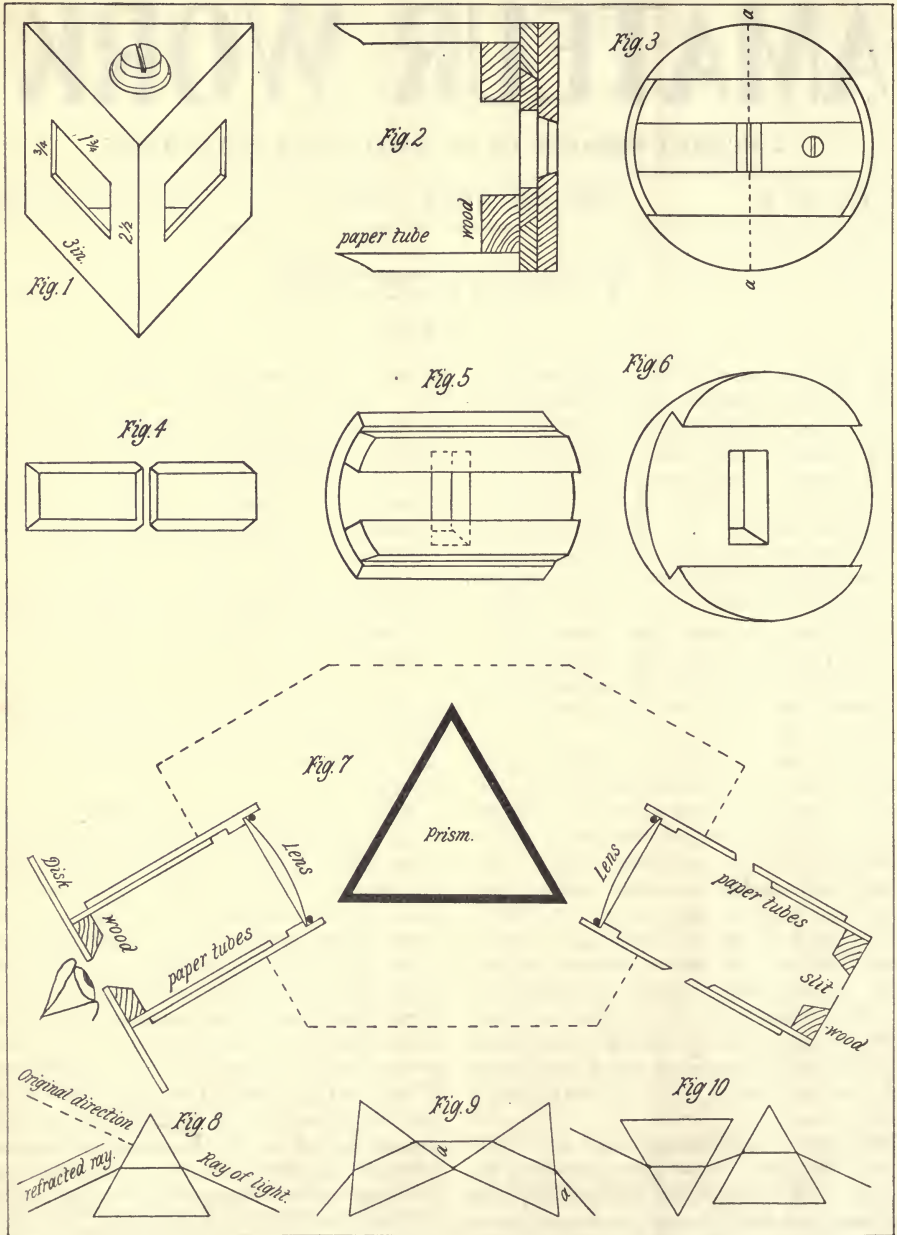

Fig. 4, being the slit goes into Fig. 5, and Fig. 5 into Fig. 6. Fig. 5, is made movable when desirable; either end of the spectrum may be brought into the centre of vision without disturbing the slit when once adjusted.

The slit proper, Fig. 4, should be made of brass or any other metal capable of receiving a high polish, the higher the polish the finer the result. The vertical joint should be perfect. One side of the slit should be made fast with a screw as shown in Fig. 3. Fig. 7 shows the arrangement of prism, lens and tubes. The lenses are held in position by gluing on the inside a piece of the mailing tube and using a piece of spring brass wire bent around the inner side of tube and pressed firmly against the lens. The eye tube is drawn about half scale, the collimator tube is shown broken, the length being determined by the focal length of lens used. The disk on eye tube is to shield the eye from outside light.

Having completed the necessary parts it now remains to place them in position, which can be done in a systematic manner avoiding all guess work. Take a flat board, on this draw two lines to equal 130° , providing the prism has been made equilateral. Let these lines represent the centre of the tubes, also of prism, on the horizontal or ground plane. Draw parallel lines equal to half the diameter of tubes. These will serve as guides for the outside of tubes; they are then blocked up until the centre of tubes corresponds with the centre of opening in the sides of prism, which may now be placed in position; the side having no opening should make an equal angle between the two tubes. This may be done by bi-sectioning the angle of 130° and drawing a number of parallel lines at right angles to the line of bi-section. These lines will serve as guides, should it be necessary to move the prism in adjustment. By using a little care there should be very little movement, the object being to bring the colored band in the centre of vision.

When everything has been adjusted satisfactorily, a box should be made out of $\frac{3}{8}$ " or $\frac{1}{2}$ " stock in form as indicated by dotted line in Fig. 7, two sides of the box being laid out at right angles to the tubes, and holes bored in position to take the tubes firmly, yet allowing them to be drawn out when necessary. When the final adjustment of prism is made, small strips of wood should be

glued on inside of box to hold the prism in position. Make cover of box to fit to prevent any stray light from striking the prism. The inside of the box and tubes should now be painted a dead black to prevent reflections.

Fig. 8 shows a ray of light entering the prism, its original direction, and refraction. A single lens, or a compound eyepiece, may be used; if the latter, it will require two two-plane convex lenses of about 9" focus. Should they be used singly the collimator tube which contains the slot should be of sufficient length to allow for telescoping to the focus of the single lens, 9", and sufficient length remaining in the outer tube to hold firmly. If the eye is normal, the slot may be placed at its focus by measurement; however, if the slot is not sharp, the Fraunhofer lines will not show distinctly when the slot is adjusted to a fine hair line. Should the lines not be visible, then move the inner tube in and out until they are visible. Should horizontal lines appear, it indicates that the edges of the slot have not the requisite smoothness.

In using the compound form of eyepiece, each lens being of 9" focal length, the distance they are to be placed apart is equal to two-thirds the focal length of either lens. If of unequal focal length, the distance they are to be placed apart is equal to one-third their sum. This compound arrangement shortens the focus, or makes the position of the slot much nearer to the lens, the position being obtained thus:—divide the product of their focal length by their sum, less the distance between them. This approximate position being found, a slight movement either way will suit the eye condition.

In making this simple spectroscope, it is not necessary that the conditions about lenses or size of prism should be exactly followed. Should one have an opera glass, the field lens can be used, either singly or in compound. If used in compound, then the distance between them must be obtained by the above rule, and a prism made in size to suit, or two glass prisms, such as are to be found in many schools, their arrangement being shown in Fig. 9 and 10, keeping the angles a , a , equal. The larger the surface of the prisms, the greater is the initial spread.

The Amateur lathe is very popular.

LANTERN SLIDE MAKING.

R. G. HARRIS.

III. Commercial Lantern Plates.

At the present time nearly the whole of the lantern slides produced by the vast army of lantern slide workers are made on commercial lantern plates. Their convenience and excellence have won for them an impregnable position in public favor, which is not yet without justification. The colors obtained upon the ordinary commercial plate range from an admirable black through browns to red, and even purple, should anyone have a taste for claret colored-lantern slides. The classification of colors obtainable on a gelatine plate has been extended *ad nauseam*, and is often merely an individual statement of accidental results, the "rich sepia" of one man being the "warm brown" of another, the ingenuity shown in framing formulae to obtain these results having served to encumber the pages of photographic literature with a mass of recipes utterly bewildering to the uninitiated. The colors most generally useful are black, warm black, brown and warm brown.

To obtain any of these colors with certainty and to repeat the exact color obtained upon one occasion at any subsequent time is not easy, and the slide maker will find that he is forced more or less to compromise by accepting considerable departures from any standard color. Each worker, therefore, must adjust the developer to his own personal equation and method of working. The formula given in this chapter will be found to give the color described with tolerable exactitude, but as the worker in lantern slide operations progresses he will most certainly modify any formula that comes into his hands to suit his own requirements.

Before proceeding to a detailed account of the development of gelatine lantern plates, it may be well to mention that color in lantern slide work, more especially when made on gelatine plates, is almost entirely a matter of exposure followed by suitably adjusted development. Any reducing agent, hydrokinone, metol, eikonogen, etc. will give either warm or black colored slides

if modified to suit the exposure. Short exposures in a strong light, followed by quick development, tend to the production of black colors, while long exposures, coupled with protracted development, result in colors more or less red. If therefore, the beginner bears this in mind, he will be able to make a rational application of any developer. In connection with this point, it may be interesting to give the results of some experiments made by H. Liesegang, and published in the *Photografyic Cyronik*.

Color.	Proportionate exposure.	Concentration of developer.
Greenish black	1	1 to 5
Olive brown	2	1 to 5
Sepia	3	1 to 10
Brown	4	1 to 10
Red brown	6	1 to 20
Yellowish brown	8	1 to 20
Red	5	1 to 30
Reddish	10	1 to 30
Yellow	20	1 to 40

Although these results were derived from a series of experiments on the development of silver chloride, they agree very closely with what the lantern slide worker finds to be the case with gelatine lantern plates, which, in fact, are largely composed of silver chloride. The production of black colors in lantern slides calls for no special skill on the part of the worker; so long as he uses a clean, quick working developer and gives a short exposure, the rest is easy. In camera reduction, when working for black colors the light outside, if daylight methods are used, must be sufficiently good to give a well exposed plate with six to ten seconds exposure, and when "contact" exposures are made, the illuminant is better fitted for the production of black colors if it takes the form of an incandescent gas mantel. With such a light, and a negative of medium density held at a distance of about eighteen inches from it, the exposure need not exceed ten seconds. Any of the modern reducing agents will give black colors, but each one has a particular shade of black peculiar to itself. Thus, hydroquinone

gives a black that often assumes a greenish hue, especially with caustic alkalis; metol is characterized by its bluish black; and eikonogen has a very pleasing olive black. Amidol, in my opinion, gives the nearest approach to a pure black of any developer, though it is run very close by Edinol.

It will be seen from a consideration of the above peculiarities what a considerable undertaking it would be to give formula embracing all the recently introduced developers, with their varying shades of colors. I shall content myself with giving here several simple formulas, which are the sublimated results of many month's experiment among modern developers. Once the lantern worker has passed through his apprenticeship, he will find the field of modern developers extensive enough to afford him many months' work, and the result will be sufficiently varied to suit the most exacting.

AMIDOL DEVELOPER (FOR BLACK.)

Amidol	20 grains
Sodium sulphite	240 grains
Potassium bromide	10 grains
Water	10 ounces

Development is very rapid, but it is necessary to give a seemingly excessive opacity to compensate for the loss of fixing. Any "forcing" of development through under exposure is to be carefully avoided in lantern slide work. The development should bring out the detail steadily through the various graduations, until the extreme highlights appear, and these should remain perfectly clear while the slide is acquiring sufficient opacity.

When development is judged complete, the slide is quickly placed, without any washing, in an acid fixing bath. It is a mistake to submit lantern slides to a washing process between development and fixing, as during the process the slide acquires sufficient density to cover the highest lights that have been so zealously guarded. I am aware that many hands have been uplifted against the use of an acid fixing bath, and probably will be continued to be raised until the end of the tale. My own experience is absolutely in its favor, and I have constantly employed it in the form given below for the last fourteen or fifteen years. For lantern slide work I particularly recommend its employment. Fading, marks of any and every description, have at various

times been attributed to its employment, but in my fifteen years experience I have never found either a negative or lantern slide fade, and I see no reason, if properly made, for an acid fixing bath to cause fading.

The bath referred to is prepared by dissolving in ten ounces of water one ounce of sodium bisulphite; in another ten ounces of water four ounces of sodium hyposulphite are dissolved; and then, while stirring, the bisulphite solution is poured slowly into the soda solution. When mixed, the formula will stand thus:

Sodium hyposulphite	4 ounces
Sodium bisulphite	1 ounce
Water	20 ounces

On removing the slide from the fixing bath and examining it before a piece of opal or ground glass, it should appear "crisp" without any appearance of "inkiness" in the shadows, and when laid upon a sheet of white paper the extreme high lights should have the appearance of being bare glass.

AMIDOL DEVELOPER (FOR WARM BLACK.)

Amidol	20 grains
Sodium sulphite	240 "
Ammonium carbonate	20 "
Potassium bromide	20 "
Water	10 ounces

The exposure for warm black colors when using the above developer will be about double the exposure required for black, and development will be rather slower; it should not be carried so far, however. When the production of warm colors is attempted with gelatine plates, it is better to adopt pyrogallol as the developer. Now that warm colors cannot be obtained with the modern reducing agents, but "pyro" and ammonia undoubtedly produce them with greater facility than do the others. The subjoined formula has given in my hands very good browns with above five times the exposure needful for blacks. With some plates, to produce brown colors, it may be necessary to add more bromide.

PYROGALLOL DEVELOPER (FOR BROWN.)

A. Pyrogallol	30 grains
Sodium sulphite	120 grains
Citric acid	3 grains
Water	10 ounces
B. Ammonium bromide	40 grains
Liquor ammonia (.880)	30 minims
Water	10 ounces

Equal parts of each are taken to develop.

It will be noticed when developing for warm colors that the image develops in a manner differ-

ent from a black colored image. With black images the gradations appear crisply defined on the surface of the film, but with warm colored images the picture seems buried in the film, and is only seen when examining the plate by transmitted light. This appearance is rather puzzling to the novice, and misleads him into giving greater density to the plate than is desirable. Only experience can enable him to judge when correct opacity has been reached, but he will find, where warm colors are in question, that a very small amount of apparent density will prove on fixing to have been ample.

The development of lantern plates in the production of warm colors is oftentimes a tedious operation, requiring perhaps ten or fifteen minutes, and there seems no way of curtailing and retaining at the same time the quality of the image. Loss of time may be prevented by using a grooved tank and leaving the plates to develop while other exposures are being made. Development is so slow that overdevelopment need never be below 65° F. Should warmer colors than those given by the above developer be required, they may be obtained by adding to each ounce of the mixed developer twenty or thirty minims of a

ten per cent solution of ammonium carbonate. It has been stated, but not on sufficiently good authority, that the use of carbonate causes fading. In place of adding the carbonate as a ten per cent solution, it may be combined with the developer in bulk, in which case the following formula is a convenient one:

PHROGALLOL DEVELOPER (FOR WARM BROWN.)

A. Pyrogallol	20 grains
Ammonium bromide	20 "
Sodium sulphite	120 "
Sulphite acid	25 minims
Water	10 ounces
B. Liquid ammonia (.880)	100 minims
Ammonium carbonate	20 grains
Water	10 ounces

Equal parts of each are taken to develop.

The formula given in this chapter will cover the whole field of the development of gelatine lantern slides. Success in lantern slide work is due not so much to any special formula as to continued practice on the part of the operator. The production of first class slides as regards crispness, color, and exact density is not, in my experience, too easy of attainment, nor does there appear to be any "royal road" to such an end.

Photography.

PATTERN MAKING FOR AMATEURS.

F. W. PUTNAM.

Planes and Other Tools. — First Exercise.

The first requisite in the way of tools and appliances will be a carpenter's bench. Many readers will doubtless have a bench which will be entirely satisfactory for this work, and I will, therefore, only briefly outline directions for making a bench which can be readily taken apart at any time. For this bench the following pieces of stock will be required:—Three pieces of spruce 2" x 5" and 3' long, as supports for the top, and two pine boards 12' long, 12" wide and 1" thick for the sides. These side boards should be nailed firmly to the 2" x 5" cross pieces just mentioned. For the top use maple 1 ¼" thick if procurable, otherwise clear white pine of the same thickness. This top is to be fastened firmly to the cross pieces, preferably with 2" No. 12 wood screws.

The legs are made from 2" x 5" spruce, the length of the legs depending upon the size of the workman. Fasten a piece of spruce 1" x 3" across each pair of legs, making a halved joint about 6" from the bottom, placing the legs at the distance apart necessary for the width of the bench top. Cut a slit or opening in the top end of each leg, in order to straddle the cross piece at the ends, and put a 2 ½" bolt 3 ¾" long, through each leg and through the side boards, and the bench is complete. This can be taken down very quickly by simply removing the bolts from the legs.

A complete list of the tools necessary for the pattern work will not be given at this time, but a few hints on planes and chisels are desirable.

Later on, other tools and their application to the various patterns will be considered. The first operation to be understood by the pattern maker is the grinding of a chisel and a planer blade. If the reader will refer to the articles on "Wood Turning" and the portion dealing with the sharpening of turning tools, and if he will also read carefully the excellent article on "The Grindstone and its use" in the January, 1904, issue of *AMATEUR WORK*, this question will be found quite fully presented.

There are three common planes used by the pattern maker. The Jack Plane, Fig. 4, is used for removing the rough outside surface; the plane

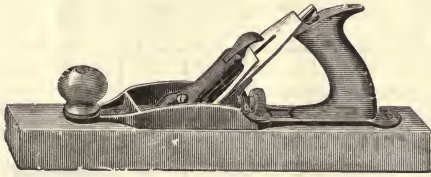

FIG. 4. JACK PLANE.

stock is generally made of beech, and the plane iron of cast steel. The blade cuts best when it is ground rounding at the corners, thus producing a slightly curved edge. This is the proper tool to use in removing a surplus of stock. The Smoother, Fig. 5, is an iron plane from 12" to 14" long, and is used for smoothing off the stock

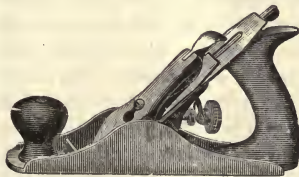

FIG. 5. SMOOTHER PLANE.

after being "roughed down" with the Jack plane. The blade is ground with a straight edge. The Block Plane, Fig. 6, is a short iron plane from 5" to 7" long, and is used for cutting across the end grain. The cutting iron is placed in the plane with the bevel on the top side.

Good planes can oftentimes be bought second hand, at a much lower price than new ones. A good *old* plane often works better than a new one, as the latter is quite apt to bother a novice, defying all his efforts to get it to plane a true

surface. If second hand tools are to be bought, by all means enlist the aid of some friendly carpenter. The chisels and gouges had better be purchased new. To use a chisel successfully requires a great deal of experience. Two kinds of chisels are used by pattern makers, paring chisels

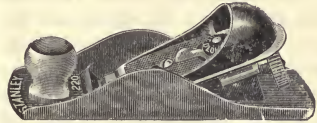

FIG. 6. BLOCK PLANE.

and firmer chisels. The former is used entirely by hand pressure, and the latter is used with a mallet. The paring chisel is much the longer of the two. A chisel should not be used both as a paring and firmer chisel, as the paring chisel must be kept with a very sharp edge. It is advisable to have several chisels running in width from $\frac{1}{8}$ " to $1\frac{1}{2}$ ", the latter being the best width for the paring chisel.



FIG. 7.

BEVEL
EDGE
CHISEL.

The grain of the wood must be thoroughly understood before one can pare smoothly with a chisel. To pare smoothly across the grain, hold the chisel edge at an angle to the fibres of the wood, the motion of the chisel being directly across the grain. In paring end grain the chisel should be given a motion across the end grain as well as a downward motion. Joints that are mortised or dovetailed, require a bevel edge chisel, as shown in Fig. 7. Chisels are sharpened in exactly the same manner as plane irons, but, being generally much narrower; they require special attention in the grinding so not to get a heavy feather or wire edge.

DRAFT.

Patterns should always have a little taper to the parts entering into the sand, in order to assist in their removal from the same, when their use will not be materially interfered with by such tapering. The pattern maker, therefore, works most of the thicknesses and the sides or edges, both internal

and external, a little out of parallel or square. When foundry patterns have their sides exactly parallel, the friction of the sand against their sides is great enough when they penetrate deeply, to require considerable force to extract them; the pulling of the pattern is very apt to tear down the sand unless the patterns are much knocked about in the mould to enlarge the space around them. This rough usage frequently injures the pattern, and causes the castings to become irregularly larger than intended, and also defective in shape. All these evils are much lessened when the patterns are tapered and made perfectly smooth. This tapering is called the *draft*, and for small patterns, a taper of $\frac{1}{8}''$ per foot is sufficient. The surface from which the draft runs is called the *face* of the pattern and is usually the upper surface of the mould, when the pattern is drawn.

SHRINKAGE.

An iron casting is always somewhat smaller than the mould in which it is made, and consequently smaller than the pattern. This is true of castings made from any of the common metals. Shrinkage of the metals when cooling, causes this difference in size. The amount of shrinkage will vary with the shape and size of the casting, and also with the kind of metal employed. The following allowances for shrinkage are made by pattern makers for ordinary purposes:—

Cast Iron, $\frac{1}{8}''$ to $12''$. Aluminum, $\frac{1}{4}''$ to $12''$.

Yellow Brass, $\frac{3}{32}''$ to $12''$. Lead, $\frac{1}{4}''$ to $12''$.

FINISH.

If the surface of a casting is to be cut away or finished, an allowance equal to the amount removed is always added to the pattern, and is called an allowance for *Finish*. The allowance must always be great enough to allow for removing all scale and have the clean metal exposed. For ordinary small patterns $\frac{1}{16}''$ to $\frac{1}{4}''$ should be allowed, over and above the finished dimensions. As the size of the casting increases, the surface is liable to become rough and uneven, its irregularities and the total amount of shrinkage increase, and so a greater allowance for finish must be made. To avoid the necessity of making frequent calculations to determine the allowance for shrinkage and finish, pattern makers use a rule called a *Shrink Rule*. This rule is $24\frac{1}{4}''$ long, standard measure, and is divided in the same

manner as the standard rule into inches and subdivisions of an inch.

RIBBED PLATE.

For our exercise we will make a pattern for a ribbed plate as shown in Fig. 8. The right end view of the plate is shown in section and indicates that two blocks are to be used for this pattern. The top surface of the pattern is marked *a* and the arrow indicates the direction in which the pattern is to be drawn from the mould. It will be noticed that the top surface is marked with an *f*. This is to be always understood as indicating that the surface upon which this mark is placed is to be finished in the machine shop.

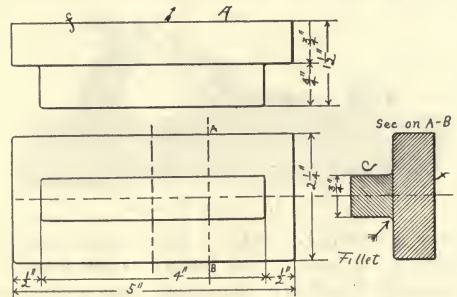

FIG. 8. RIBBED PLATE.

The dimensions in Fig. 8 indicate the size of the finished casting. If you have carefully studied the meaning of draft and finish, as applied to patterns, you will have no difficulty in making the necessary allowances. The planer blade can be set over from the centre so that the draft can easily be planed on the sides of the blocks. If you are without a block plane, a paring chisel or a wood rasp may be used on the ends. In any case, make sure that the taper is straight and in the right direction. If the taper is put in the wrong direction the pattern is said to have *back draft*, and if there is no taper there is said to be *absence of draft*. The tongue *C*, Fig. 8, is glued and nailed to the plate with four $1\frac{1}{4}''$ No. 16 wire brads.

GLUE.

Glue naturally suggests itself as an indispensable means of attachment. There is, however, a decided objection to its use in pattern work, as it does not stand contact with the damp sand. If the joint does hold, the glue will ooze out all

round, and will, unless carefully removed, cause a hard line of sand to stick to the pattern, thus spoiling what would otherwise be a good mould. Much depends on this glue in cases when patterns cannot be nailed or screwed, and it becomes absolutely necessary that only first class glue be employed. Among the many qualities of glue in the market are liquid, pulverized, and sheet glue. The liquid glue is good in quality and very handy for small light work, as it is always ready for use. The sheet or flake form dissolved and used hot is, however, preferred for general work.

Animal glue is generally considered the best, it comes in thin sheets and is the most expensive. As a rule, the best quality of glue is *amber* in color, and the flakes are quite thin. Glue should be soaked in cold water before placing it in the glue pot, but the soaking should never be continued for any great length of time, as this injures the quality. Glue is strongest when freshly prepared and, if of good quality, can be drawn out into very fine threads. As a rule, the harder the glue, the better it will resist moisture. In gluing two pieces together, the glue must be thin enough to spread evenly; if the surfaces to be glued can be warmed, a much better joint may be obtained. Make sure that the surfaces to be glued are wiped clean of any dust before the glue is applied. This is especially true in the case of surfaces that have been sandpapered, for in this case the dust has probably been rubbed into the pores of the wood, and so closing them to the entrance of the glue.

When the end grain of wood is to be glued, give it a heavy sizing coat first. This is done to fill the openings among the fibres. When this sizing coat has become hard, the surfaces are given a second coat of glue and clamped together. If this is not done, the open end grain will probably absorb the glue so rapidly as to seriously weaken the joint. Plenty of time should be given the glue to set; in most cases, twelve hours in a dry place is sufficient.

FILLETS.

It will be noticed in Fig. 8, that at the joint between the blocks a sharp corner is avoided, and a rounded corner made instead. Sharp corners, whether inside or outside of a pattern, should be avoided, and whenever there is nothing to interfere, all corners should be slightly round-

ed. Sharp corners in a pattern will form sharp corners of sand when moulding, and these corners will give the moulder a great deal of trouble. Sharp corners, generally, not only detract greatly from the appearance of the pattern, but also injure its strength.

To overcome these difficulties, a *fillet* is generally placed at the sharp angle or corner, as indicated in Fig. 8. To form this fillet on the pattern for the ribbed plate, melt some beeswax and run into the corner with a short piece of fairly large wire, say, $\frac{1}{8}$ " in diameter. When this wax is thoroughly hard, any excess may be scraped off and the surfaces lightly sandpapered. All wooden patterns require covering with some protective coating, to prevent warping and cracking from the influence of the moist sand in the mould, and also to prevent the glued joints from coming apart. This protective coating is not affected by moisture, and gives a smooth surface that draws easily from the sand. This will be taken up in the next chapter.

A MODEL STEAMBOAT.

CARL A. CLARK.

IV. The Boiler Fittings.

The next proceeding will be to fit up the boiler with steam gauge, safety valve, water glass, etc. It is recommended that the fittings be purchased of some of the dealers in such articles, as they are extremely fussy and difficult to make, and cost very little to buy.

The safety valve should be fitted in the position marked on sketch shown in the previous chapter, and should be set for 50 lbs. pressure per square inch. If screwed in, the hole in the boiler should be topped the correct size, and the valve screwed in tightly, after being smeared with red lead. The steam gauge is tapped in at any convenient place, in the steam space, preferably somewhere on the front head. There are frequently set on tube extension so as to be seen on deck. It should indicate up to 75 lbs. per sq. inch, that it may be used in testing. The water column is attached in the position shown by the two holes just above and below the water level. It must, of course, be brought out beyond the uptake, either in front or to one side.

The feed pipe is attached at the small reinforcing piece just below the uptake. From the point marked "steam outlet" the steam is taken; a small valve is put on next to the boiler to regulate or cut off the supply of steam to the engine. The steam pipe is a brass or copper pipe about $\frac{1}{2}$ " diameter, bent to shape,

CONTINUED ON PAGE 165.

A WIRELESS TELEGRAPH RECEIVER.

S. W. LINDSAY.

Most wireless telegraph receivers are complicated, expensive and somewhat speculative, the results from them depending very materially upon one's skill and experience. Only a small percentage of the receivers produced by the more prominent wireless companies properly perform the service intended of them; but the instrument described below is simple, cheap and positive in its workings.

as a needle, resting against the carbons. There are two methods of supporting the needle. One is by a spring of light tension hung from a bent wire support as shown in the photograph. The spring can be made by turning brass wire around a pencil or small round stick. The other method is to bore a small hole in (but not through) each carbon, placed so that they point towards each other. Then between them the needle is fixed

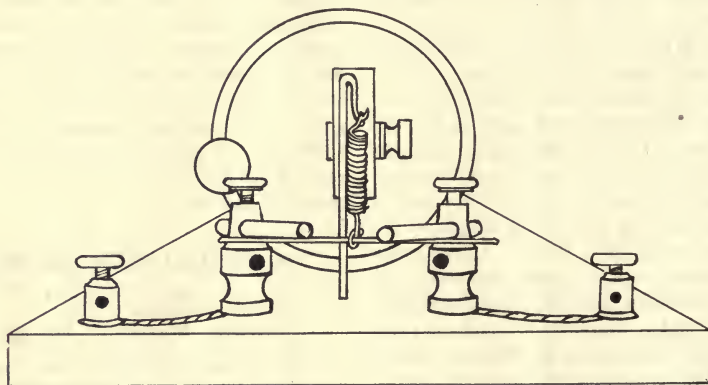

Mounted by means of tin straps on a base of wood, 6" x 10 $\frac{1}{2}$ " x 1", is an ordinary dry battery, at each terminal or pole of which is a double screw binding post. Each of these binding posts carries a stick of carbon in its upper hole, about $\frac{1}{8}$ " in diameter and 1 $\frac{1}{2}$ " long, converging slightly. The lower hole of one post is connected with the carbon of the battery by a piece of neatly-coiled wire, leaving the zinc and the lower hole of the other binding-post free to make connection with the telephone receiver.

One and one-half inches from each of these binding posts and connected with them by a stout wire (which may be placed in a groove and is screwed down under the posts) is a single wood screw binding post. The screw on the telephone side is for the earth connection and the other is for the air wire, or antennae. The principle of the instrument is, as in other receivers, imperfect contact of conductors. In this instance it is formed by a highly polished piece of steel, such

the ends resting in the holes mentioned. The needle thus makes a slight but firm contact.

When all are assembled the circuit is completed through the telephone receiver in which the signals are made audible as buzzes, the long ones being dashes, the short ones dots. Superior results can be obtained when the oscillation at the spark gap of the sending apparatus is very rapid, spreading waves in rapid succession. The reading of the signals, either in the American or Continental Morse Code, is simple, and with but little practice any one can take messages easily and accurately.

Compared with other receivers tested by the writer, the one described above is the most satisfactory because of its reliability and simplicity. Under conditions where all others would cease working and demand re-adjustment, it remained the same for days at a time. Beside, it admits of much handling, and works immediately upon being set up, catching the first signals clearly.

A SENSITIVE RELAY.

ARTHUR H. BELL.

The relay used in the coherer circuit of a wireless telegraph receiver must be of the highest sensibility. The resistance of the magnet windings should be at least 1000 ohms for experimental work at short distances, and upwards to 5000 for practical field work. With the higher relays, the armature will operate or "throw over" with one volt throughout 30,000 to 50,000 ohms resistance, and it is this extreme sensibility which commends it to wireless specialists.

To the amateur who wishes to progress as far as possible in his researches with a limited expenditure of money, the cost of these relays would at first seem prohibitive, but it is the purpose of this article to explain the construction of a relay which is giving good satisfaction and which was completed for a reasonably small sum. The manner in which this relay operates reminds one of the vibrating attachment to a simple induction coil.

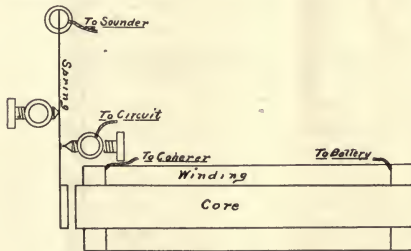

The electro-magnet consists of two square pieces of wood, $1\frac{1}{2}'' \times 1\frac{1}{2}'' \times \frac{3}{8}''$ thick, each having a $\frac{3}{4}''$ hole through the centre. A bundle of fine annealed iron wires as fine as No. 24, or still finer if possible, 6" long and $\frac{3}{4}''$ in diameter is next procured, and one of the wooden squares glued securely on at each end, the iron core projecting outward a half inch at one end. This core is evenly wound with the finest magnet wire at one's command. The writer used No. 36 for a greater portion, and No. 34 to finish winding to the full capacity of the bobbin, having the same on hand, but it is best to use only one size, No. 36. It will be found that a weak cell of dry bat-

tery, not strong enough to ring a vibrating bell, will energize this core sufficient to attract iron filings through quite an air space. When completed the magnet is glued or screwed down to a base board of smooth wood about $4'' \times 8''$.

There is a kind of ribbon steel, similar to clock spring stock, which may be purchased of clock repairers, in small lengths. This is remarkably flexible, and should be procured in a perfectly straight strip $4''$ long and about $\frac{1}{4}''$ to $\frac{3}{8}''$ wide. This is to form the spring for the armature. At one end is soldered the armature, a soft iron disc about $\frac{1}{8}''$ thick and $\frac{3}{4}''$ diameter. The other end is fastened to a small upright pillar post, placed in such a location on the base board that the iron disc is just opposite the magnet core, and $\frac{1}{8}''$ away from it. It will be found that this armature will respond to a very feeble current passed through the coil. The contacts are similar to those on an induction coil, only of course, the contact screw is on the other side of the vibrator, and touches to make contact only when the magnet is energized. It is a good idea to mount an adjustment screw to press on the outside of the spring vibrator, so as to closely adjust it in relation to the magnet and the contact screw. The contact on the contact screw must be a platinum point, and on the spring vibrator a little point of platinum is also necessary, for a perfect electrical contact is very essential.

There are four binding posts, two for the coil terminals and two for the relayed side. One binding post is connected to the vibrator and the other to the pillar contact post. In the construction of a relay as here described, the making of pivots and other difficult parts is avoided. It will also suggest other types, perhaps better adapted to the experimenter's particular requirements, as the study of wireless telegraphy is continued.

The gasoline engine is rapidly replacing steam as a motive power for automobiles and launches, as shown by recent exhibitions of same.

A STILL FOR WATER.

R. G. GRISWOLD.

Distilled water is being used for so many purposes, especially in the dark room, that every worker in this line should have a still with which he may provide himself with a liberal quantity of pure water. The following description tells how to make a very cheap but efficient still. It may be operated in any manner that best suits the convenience of the operator, and if placed on the rear of a stove will work continuously all day without much attention, and with no cost of fuel as the cook stove generally runs for the entire day, whether meals are being cooked or not.

tight enough as the steam pressure is very low, but if too much escapes, slip a rubber band around the lower end of the taper and then insert in the neck. This will make a steam tight gasket.

The condenser may be made from a large size tomato can that has had the ragged edge melted off. Two $\frac{1}{4}$ " brass tubes are soldered to its sides, one for the inlet through which the cooling water is poured and the other an outlet which carries away the hot water from the top to a pail or other receptable on the floor.

The condensing worm is made of $\frac{3}{8}$ " block tin

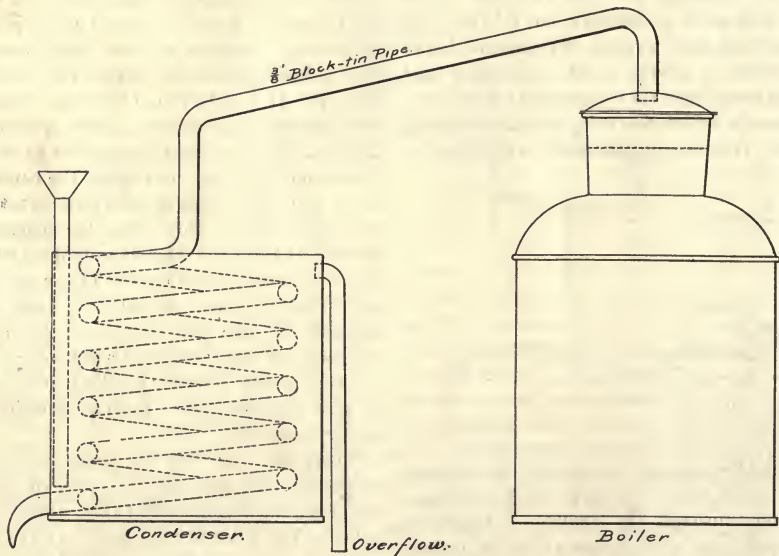

Make the boiler out of a common milk can that has a taper-fitted lid or stopper. Melt the handle off the lid and punch a hole in the centre large enough to admit the end of a $\frac{3}{8}$ " block tin pipe. In soldering this pipe in place great care will have to be exercised as the tin pipe will readily melt with a hot soldering iron. A piece of wet cotton put inside the tube at the point of soldering will sometimes prevent this accident. The taper of the lid will generally shut the boiler

pipe, such as druggists use in their soda fountains, as this does not dissolve in the condensing water; neither does it corrode. About four feet will be amply sufficient and it may be rolled around an ordinary bottle to give it the coil shape. The end is passed through a hole in the bottom of the can and soldered there. If the end is nicely shaved off to make a lip as shown, the water will drop off and into a receptable without splattering or running around the end of the tube.

Of course it would be better, to make the cans of copper, tin lined as they would never rust, which the tin will quickly do. This rust, however, has no effect upon the purity of the water as none of it passes over, and the cans are so cheap that they may be readily replaced when rusted through. The supply of cooling water may be supplied through a small rubber tube from a bucket overhead, using a small tube as a siphon. This still will be found very efficient, and with an ordinary Bunsen burner under the boiler will give about two gallons of water per day.

A ROTARY INTERRUPTER.

The following is a description of a rotary interrupter which, when neatly constructed, should give higher frequency results than may be obtained with the ordinary type of vibrator. The first requisite is a small but well made electric motor, of a type similar to those sold by electrical supply dealers for toys. It may be necessary to remount the motor on a larger base. With two or three cells of battery, the motor should develop from one to two thousand revolutions per minute even when some friction is applied to the shaft.

Procure a piece of extra heavy brass tubing, 1" in diameter, and $\frac{3}{4}$ " long. Smooth both edges, and solder securely to one end a disc of sheet brass of same diameter as the outside diameter of the tube. This will now resemble a cover to a small round metal box. Find the centre of this disc and mark off into four equal parts. With a knife blade, file or jeweller's hack saw, cut four slots in the surface of the cylinder, as if making four segments for a commutator. Then remove two opposite segments of the tube, using great care not to weaken the joints of the two remaining segments. On a piece of whitewood or pine, $\frac{3}{8}$ " thick, place the end of the brass tube, and sketch thereon the outline of a plug which shall be a tight fit for, and at the same time conform to, the cylindrical contour of the tube. This plug should be secured in place with brass brads or very small brass screws. Measure the diameter of the motor shaft and drill a hole through the plug so it will fit on the shaft like a pulley. Perhaps an easier way to make the plug would be to find a spool of the right size and file slots in it for the brass tube.

There are to be two brushes, one directly opposite the other. These may be of fine copper or brass gauze, or thin spring brass. These are bent to an L shape, the bend at the lower end being attached to the base board with two round head brass screws, one serving for connection with coil.

Connect one terminal of the coil battery to one brush and the other brush to one terminal of the primary winding, and the second terminal of the primary to the other terminal of the battery. A separate set of batteries is used to drive the motor. It will be seen that every revolution of this "commutator" means two interruptions of the current because, when the brushes rest on the brass segments, a circuit is established, and when on the wood the circuit is broken. After experimenting for a time with this interrupter, the amateur may make a cylinder with more segments, which will of course increase the frequency.

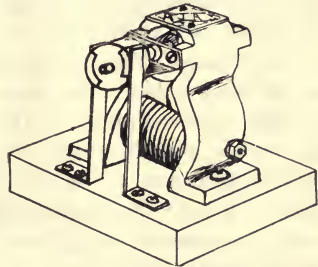

In an induction coil, the instantaneous values of the secondary are proportional to the product of the ratio of transformation and the instantaneous pressure upon the primary (disregarding iron losses in the core.) To secure the greatest efficiency, the primary current should be broken as soon as it reaches its maximum value. And when the break occurs, it must be quick and "clean cut" as it were, so as to give the highest voltage in the secondary. It will, therefore, be seen that the above described "commutator interrupter" can be changed and improved somewhat in the design of the segments, by making them wider with less space between so as to give a greater period of time in the "make" and less in the "break" but it would be a good idea to first make one as described, and from it become acquainted with its action.

Renew your subscription promptly.

AMATEUR WORK

77 WILBY ST., BOSTON

DRAPER PUBLISHING CO., PUBLISHERS.

A Monthly Magazine of the Useful Arts and Sciences. Published on the first of each month for the benefit and instruction of the amateur worker.

Subscription Rates for the United States, Canada and Mexico \$1.00 per year. Single copies of any number in current volume, 10 cents.

TO ADVERTISERS.

New advertisements, or changes, intended for a particular issue, should reach the office on or before the 15th of the previous month.

Entered at the Post-office, Boston, as second-class mail matter
Jan. 14, 1902.

APRIL, 1904.

Several very interesting articles as well as "Correspondence" are omitted from this issue, owing to lack of space. They will appear in the next issue, and at an early date the magazine will again be enlarged several pages. We know that our many readers await the successive numbers with much interest, and we, on our part, are earnestly striving to provide as much and as valuable reading as possible; feeling sure that our efforts are thoroughly appreciated.

We have received a number of letters asking for particulars about excursions to the St. Louis Fair. As quite a number of our subscribers have expressed their intention to attend, the idea of an "Amateurs" excursion has been suggested, and in that connection would be pleased to receive suggestions from our readers. The cost including all expenses, except meals enroute, would be about \$60, with one week at the Fair. The most suitable time would probably be late in July or early in August.

Cloth covers for binding volume II, AMATEUR WORK, uniform with the previous volume, will be mailed, postage paid, for 25 cents. With these covers the magazine can be taken to the nearest bindery and bound for a small sum.

BOOKS RECEIVED.

COMPENDIUM OF DRAWING. Various authors. Two volumes, 410 and 477 pp., 9 1/2 x 6 1/2. \$5.00 or \$3.00 for single volume. American School of Correspondence, Chicago, Ill.

As might be expected of any book made up of writings by several authors upon different kinds of work, there is a lack of even and progressive treatment of the subjects, but even with this disadvantage, the scope of the two volumes is so wide and the several parts so excellently and comprehensively presented, that one can easily overlook minor matters. As desk books for teachers of manual training, they would be of special value. To mechanics or others who find it desirable to have a working knowledge of the leading branches of drawing, these books would be invaluable. In fact, they are probably the most liberal value for the price of any books to be had upon this subject. Space does not permit of detail mention of the eight branches of work covered. The illustrations are numerous and well done.

LESSONS IN PHYSICS. Lothrop D. Higgins, Cloth. 379 pp. 7 1/2 x 5. 90 cents. Ginn & Co., Boston.

A course in Physics without laboratory work is very much like "Hamlet" without the chief actor, nevertheless, it is an unfortunate fact that numerous schools in this country are well nigh destitute of even the simplest apparatus for experimental work, and instruction in this most important study must be dependent, therefore, solely on what can be given with the aid of a text book. For such schools, this book is particularly well adapted, as principles are explained by references to common or familiar phenomena, the physical manifestations most commonly met in our daily life being used as illustrations wherever possible. The author has also used care in the selection of words, technical words being defined, and a glossary gives further explanations. The illustrations number 233.

MECHANICS, MOLECULAR PHYSICS AND HEAT. Robert Andrews Millikan. 244 pp. 8 1/2 x 5 1/2. \$1.50. Ginn & Co., Boston.

The close relation which should exist between classroom and laboratory is clearly appreciated by the author, who presents in this combined text-book and laboratory manual, a twelve weeks college course in which *principles* are thoroughly and logically presented, and the laboratory work arranged in close accord therewith. An especial effort has also been made to present Physics as "a science of exact measurement." The latter feature necessitates carefully designed and well made special apparatus, which should, however, be within the means and form a part of the equipment of the colleges which would find this book suitable for use. The central idea has been to present a course in compact form which would teach thoroughly a few fundamental principles, and in this, has been particularly successful. Fifteen tables and 126 illustrations

CONTINUED ON PAGE 168.

SAILING RULES FOR LAUNCHES.

CARL H. CLARK.

I. Conduct of Launches when under way.

In order to avoid collision it is necessary that vessels approaching each other, especially in crowded thoroughfares, should have some preconcerted and well understood rules and signals to signify their intentions. For this reason the "Pilot laws" have been enacted by the Government. Although these do not apply strictly to small launches, and are not always regarded by the amateur pilot, every launch owner or person running a launch should have a knowledge of them, and should accustom himself to following them as closely as circumstances will allow.

All power vessels are supposed to be equipped with whistle and running lights, and on the larger boats which are registered, these are compulsory. Small launches, which are easily handled, may be kept clear of other craft and avoid all chance of damage, but larger boats, in crowded places should by all means closely observe the following rules:-



I. Boats approaching each other, head on, should each keep to the starboard (right) and pass on the port (left) side of the other, at the same time giving a single blast of the whistle which the other must answer. It is not allowable to keep on until receiving the answering signal, showing that the other has understood. This position is shown in Fig. 1.

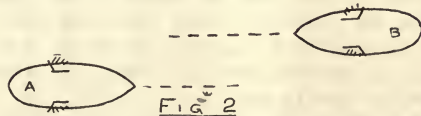

II. When the courses of the two are so far to starboard that there can be no uncertainty, as in Fig. 2, no signals are necessary.

III. When, as in Fig. 3, the courses of the two are to the port of each other, and to pass to starboard would mean a radical change of course,

each boat keeps to the left of the other passing on the starboard side, at the same time blowing the whistle twice, which shall be answered by the other.

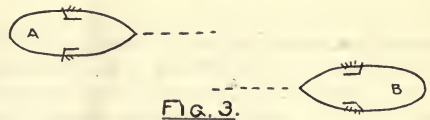

IV. When boats are approaching, as in Fig. 4, in an oblique direction, the one which has the other on her starboard side must keep out of the way of the latter, by changing her course so as to

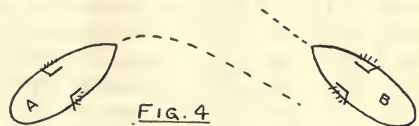

pass astern the other and blowing the whistle once. As shown, A must pass astern of B; B must hold her course and speed.

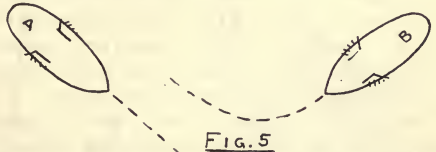

V. Approaching, as shown in Fig. 5, B must give way to A, changing her course to starboard so as to leave A on the port side, at the same time blowing the whistle once, which must be answered by B.



When one boat is overtaking another, as in Fig. 6, the overtaking boat may change her course so as to pass to the starboard of the other, after blowing one whistle and receiving the reply.

She may change her course so as to pass to port, by giving two blasts and receiving the same reply. The overtaken boat, as in Fig. 7, may show her disapproval of the course taken by the other by blowing several short whistles, but must not



change her course so as to endanger the overtaking boat. The overtaking boat must keep clear of the other. When on any course, a power boat and sailing yacht are approaching each other the power boat must keep clear.

A boat, in getting out of another boat's way, should not do so by crossing her bow, but by going under her stern. The fact of one boat having the right of way over another does not permit her to do damage to the other, and each must do her best to keep clear. It must be borne in mind, also, that these rules apply to vessels of somewhere near the same size; with a launch, for instance, it would be unwise to attempt to enforce her right of way over a steamer or large towboat. The launch, being of light draft, can be more easily kept clear, and should do so in all cases. These rules are simply for guidance and do not give a boat, even when she has the right of way, an excuse for doing damage to an offending boat or forcing her ashore.

In sailing at night the same rules hold good. The relative positions of the boats, however, are determined from the lights which each is by law bound to carry. These lights consist of a white light, a red light on the port side and a green light on the starboard side. The two latter are to be fitted with screens arranged in such a manner that the red light can be seen from all positions between right ahead, and two points aft of a beam on the port side, and the green from all points between right ahead and two points aft of a beam on the starboard side. The red must not be visible from the starboard side, nor the green from the port side. The white light is supposed to be visible from all positions.

Small open launches, under 10 tons register and propelled by gas, naphtha, or electric motors,

may show a combined lantern containing all three together.

I. Referring to Fig. 1, it is evident that each will see both lights of the other, and each will keep to the starboard, after giving one whistle.

II. In Fig. 2, each will see the red light of the other and may keep their courses after giving one whistle.

III. In Fig. 3, only the green lights of each will be visible, and all boats should keep to port, passing on the starboard side of each other after giving two whistles.

IV. In the position shown in Fig. 4, *A* sees the red light of *B* and *B* sees the green light of *A*. The courses are converging, and *A* should change his course and pass under *B*'s stern while *B* continues his course, each having given one whistle.

V. In Fig. 5 the red light of *A* is seen by *B* and *B*'s green light is visible to *A*. In this case *B* should pass under *A*'s stern and *A* should keep his course, each having whistled once. These two situations are somewhat uncertain and require care if the boats are near each other, as it is difficult to tell just how fast they are converging.

VI. In Fig. 6, *B* will see both lights of *A*, thus indicating that *A* is coming head on to *B*, while *A* will only see *B*'s red light, thus indicating to her that *B* is crossing her bow with her port side toward *A*. *A* will then change her course to pass under *B*'s stern, while *B* keeps course without change.

VII. In Fig. 7, *B* will see both lights of *A* and know that *A* is approaching him head on, while *A* will see only the green light of *B* and know that *B* is crossing his bow with her starboard side toward *A*. *A* will then change her course and pass under *B*'s stern, *B* keeping her course. When one boat can see neither red nor green light, the white light is still visible, and there is no risk of collision except by lack of care on the part of one boat overtaking another, in which case care must be used.

A boat at anchor must show a single white light. A boat is considered to be under way unless she is actually anchored, made fast to the shore or grounded. In fog or mist speed should be low and a sharp lookout kept, and the whistle or fog horn continually sounded. As before mentioned, these rules are for general guidance

in avoiding collision, and do not give the vessel or boat having the right of way the right to cause a collision.

The safest procedure for a small launch is to keep out of the way of all larger craft, and thus avoid as, far as possible, all chance of collision,

especially when not carrying lights. On the water, as in no other place, strict care and watchfulness are necessary, especially in night sailing. It is unfortunately very seldom that small launches will take the trouble to carry lights; only by keeping strict watch is collision avoided.

A PLANT STAND OR TABORET.

FRANCIS L. BAIN.

The tabourette about to be described may be made of either whitewood, basswood, or any dark colored hard wood, such as walnut or mahogany. If whitewood is used it may be stained in imitation of nearly any hard wood, while if basswood is used, an opportunity is presented for doing a little pyrography.

so when the different pieces are very wide in the finished article. If it is not possible to get the stock 13" wide, use 7" instead, gluing two pieces together to obtain the required width. As the thickness of the five pieces which make the stand is the same ($\frac{3}{4}$ " it is perhaps as well to plane the six feet of stock to that size before laying out any details. Cut the board into five pieces, as

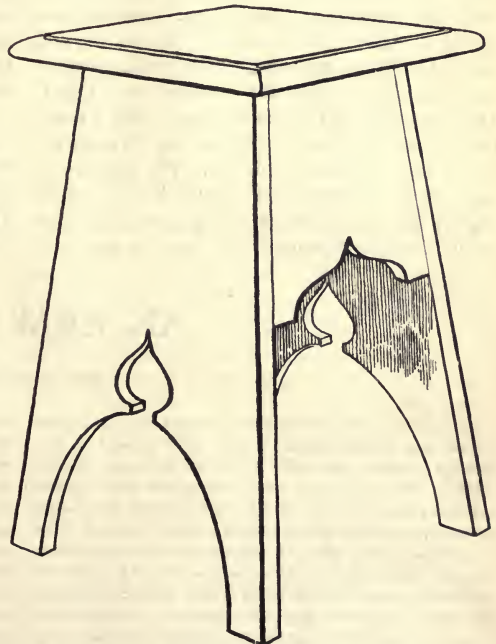
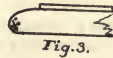
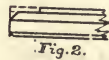
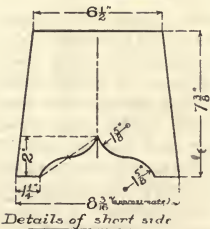
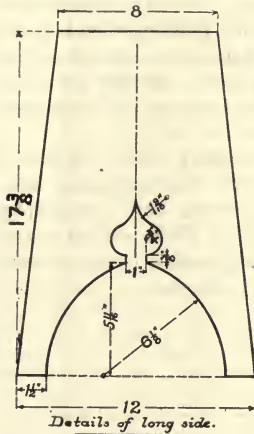

About six feet of $\frac{3}{4}$ " stock, 13" wide, will be required, and it should be thoroughly dry, as well as free from knots or checks of any kind. Well dried stock is always preferable, but especially

follows;— 2 pieces 18" long, 2 pieces 8" long, 1 piece 13" long. The 18" pieces are for the two long sides of the stand, and should be laid out very accurately and carefully according to

the figures in the detailed view of the long side.

It will be seen that an expansion bit can be used to cut out that portion of the upper part of the design where a radius of $\frac{3}{4}$ " is designated. This method should always be used when possible, as it is often difficult to cut out very small curves, and an expansion bit with the usual two cutters will answer for all holes from $\frac{1}{2}$ " to 3" in diameter. The balance of the curves may next be sawed out with either a keyhole saw or pad saw, and carefully smoothed with Nos. 1 $\frac{1}{2}$ and 0 sandpaper, a half round file first being used, if necessary. Then the sides and ends should be planed to the proper size and shape.

The two short sides should next be laid out, and finished to the proper size and shape, in practically the same manner as were the long sides, except that the expansion bit is not used. The top is to be made next, the dimensions being 12" x 12" x $\frac{3}{4}$ ". After planing to the proper size, a line should be drawn on the upper side $\frac{3}{4}$ " from and parallel with each edge. Another line should be drawn on the edges $\frac{1}{8}$ " down from and parallel with the top side. These measurements are clearly marked on the corner view in Fig. 1. These lines should then be "scored" with a sharp knife, and the corner, $\frac{3}{4}$ " wide by $\frac{1}{8}$ " deep, removed with a chisel and mallet. The square corners of the projecting lip should be beveled off slightly around as shown in Fig. 2, and the edge should then be finished to the shape as shown in

Fig. 3, a plane and sandpaper being used to accomplish this and a flat file if necessary.

The sides and top are attached to each other and held firmly in place by means of corner blocks screwed to the inner face of each side and the top by means of 1 $\frac{1}{4}$ " No. 9 wood screws. Four of these pieces should be made of pine or whitewood, the finished size being 7 $\frac{1}{4}$ " x $\frac{3}{4}$ " x $\frac{3}{4}$ ", two being screwed to the inner surface of each of the short sides, just flush with the lengthwise edges. The four sides should then be clamped firmly together in their proper position, and while in the clamps screws should be driven through the corner pieces into the long sides, thus securely attaching the sides together. Now cut out four more corner blocks similar to the first set, which shall finish 5" x $\frac{3}{4}$ " x $\frac{3}{4}$ " and screw these to the inner faces of the four sides, exactly flush with the top. Then having first drawn an 8" square in the centre of the underneath side of the top to show its proper position when in place, turn the stand upside down with the top resting upon the bench and screw through the corner blocks into the top, thus fastening the whole stand firmly together.

It will now be necessary to give the stand a thorough cleaning with fine sandpaper, after which it may be decorated with pyrography, or stained according to the stocks elected at first. This stand is especially intended for large, heavy plants such as palms, ferns, etc.

AN ARM CHAIR.

JOHN P. ARTHUR.

Antique or colonial furniture, at present so much in vogue, has many characteristics that appeal to the average person, especially as it can be made by the amateur who may have a taste for wood-working and possesses a moderate outfit of tools. There is, to such a person, a certain satisfaction in being able to show to a visitor, some piece of useful or ornamental furniture, accompanied with the statement that "I made it".

The arm chair here described is not difficult to make, is strong without being too heavy to easily move about. It should be made of straight grained white oak, which takes the much desired "dull finish" nicely, and does not easily chip or crack. Birch or maple can be used if oak is not easily obtained. In any case, the wood should be thoroughly seasoned.

All joints should be mortised, glued and pinned. Finish the several pieces to a smooth surface with a wood scraper, then sandpaper thoroughly, using about No. 1 $\frac{1}{2}$ first and finishing with No. 0. If a black finish is desired, stain with black asphaltum thinned with turpentine. After this sets (not hardens) rub down with powdered pumice stone and raw linseed oil. When thoroughly dry, apply another coat of asphaltum and oil, and rub down as before, continuing until the desired depth of color is obtained. A coat of varnish can then be added or not, according as a bright or dull finish is desired.

The legs are made of pieces 2" x 2", the front ones being 24" long, and the rear ones 40" long. The top ends of the front ones are cut in $\frac{1}{4}$ " on each side and

$\frac{1}{2}$ " from the end, leaving the ends $1\frac{1}{2}$ " square, fitting a mortise of same size cut in the under side of the front ends of the arms. The rear legs are tapered on the front sides from a point 17 " from the lower ends to the top, where they are 1 " thick, as shown in the side view. The rest of the chair is made from 1 " stock, though the arms would look better if made $1\frac{1}{2}$ " thick. The cross pieces of the seat frame are 21 " long and 3 "

strips 1 " square screwed and glued to seat frame and seat with $1\frac{1}{2}$ " wood screws.

The arms are 5 " wide at the front, cut down to 2 " wide at the back, with a rounding curve. They are 24 " long, with $\frac{1}{2}$ " tenons at the back, fitting mortises cut in rear legs. Both ends are glued and pinned. If care is used in making the tenons and mortises, a strongly built and servicable chair will result.

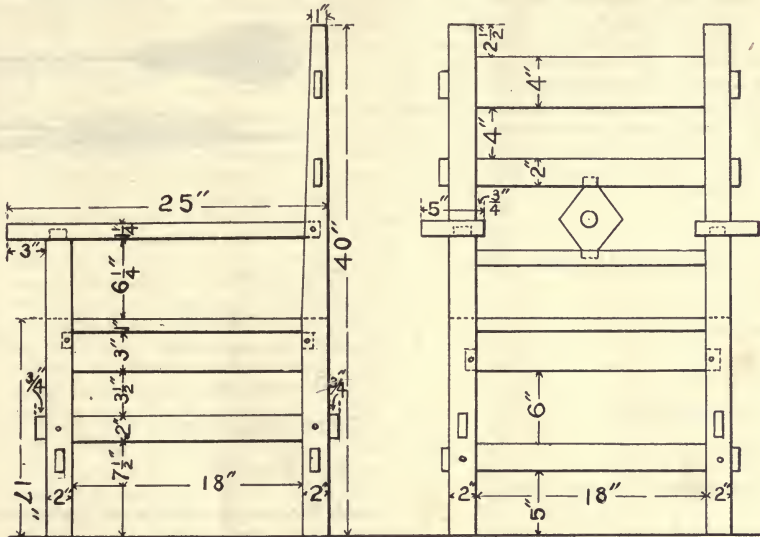

wide. They are mortised into the legs flush to the outside, making the seat 22 " square, with 2 " squares cut out at the corners to allow for legs. This gives seat frame a sort of panel effect, as the seat projects over the frame 1 " and is flush with the outside of the legs. The tenons on the cross pieces are cut only half the width, those on the side being on the lower half, and on front and back pieces on upper half, thus allowing them to pass by or cross each other in the mortises in legs, which are cut to receive them as stated.

The four cross pieces on the lower part of the chair have long tenons passing clear through mortises cut for them in the legs, the ends projecting $\frac{1}{2}$ " on outside. These pieces are $23\frac{1}{2}$ " long and 2 " wide. Those on the front and back are 5 " from floor, the two side pieces, $7\frac{1}{2}$ " from floor, allowing the mortises to be clear of each other with $\frac{1}{4}$ " of wood between. These tenons are cut $\frac{1}{2}$ " thick, giving on 1 " stock a $\frac{1}{2}$ " shoulder. The four cross pieces forming the back are 4 ", 2 " and 1 " wide, as shown in front view. The two top pieces are mortised through the rear legs, and are 24 " long. The lower piece is 20 " long with 1 " tenons at each end. The diamond at back is made of $\frac{1}{2}$ " stock, is 4 " wide, and mortised with $\frac{1}{2}$ " tenons to cross pieces above and below. The seat is fastened to frame with

The power of a steam engine should not exceed requirements if economy is to be studied. "Power" says that in reading accounts of steam engines one constantly finds statements that the engines supplied by a certain firm are capable of an overload of, it may be, 20 or 30 per cent. But if an engine rated at 100 H. P. will actually work at 130 H. P. with equal economy, it is clear that the engine has been wrongly rated. The value of a machine depends upon its economy, efficiency, and durability, and there is no worse fault than that exemplified in the phrase "making it big enough," meaning usually too big. Many a steam engine if smaller would do its work with better economy. Sometimes a man gets hold of an engine which is in first cost really cheap, being perhaps half the price of an engine of half the power; but it is really dear to him, for it is losing heat in excessive radiation, and wastes every year more in coal than was saved in the first cost.

The world's consumption of emery is 25,000 tons annually, of which Asia Minor supplies some 18,000 tons, valued at \$250,000; Canada, 388 tons, valued at \$50,000; and Naxos, 6,328 tons, valued at \$130,000.

PRINTING FOR BEGINNERS.

FREDERICK A. DRAPER.

VI. Correcting Proof.—Proof-reader's Marks..

In the previous chapter, the method of taking proofs was given. As it rarely happens that the composition is without errors of some kind, we will now consider the way to indicate and correct them. Certain signs are used to indicate the different kinds of errors, so that the compositor may know just the correction to be made. They are given, with their explanations in the following list, and by comparing them with the uncorrected and corrected examples, can quickly be committed to memory.



BODKIN AND TWEEZERS.

PROOFREADER'S MARKS.

- ⊥ Space standing too high, push down.
- # Insert space.
- ∪ Less space.
- ∨ Even spacing.
- ∪ Close up space entirely.
- X Change a bad letter.
- 9 Turned letter, i. e. upside down.
- & Dele; take out.
- Move over.
- ^ Caret; insert letters or words.
- An em quad required.
- Period.
- ,/ Comma.
- ⊙ Colon.
- ;/ Semi-colon.
- ′ Apostrophe.
- “ Quotation marks.

- / Hyphen.
- / One-em dash.
- / Two-em dash.
- TP Paragraph.
- No TP No paragraph.
- mf Wrong font.
- stet Correction made in error; let stand.
- tr Transpose.
- ≡ Caps To be set in capital letters.
- = sc To be set in small capitals.
- lc To be set in lower case.
- Ital Ital. To be set in italic.
- Rou Roman. Change italic to lower case.
- /// Straighten line.

The two instruments customarily used with which to make corrections are the bodkin and tweezers; the latter are, however, to be used with the utmost care, and even then they are very liable to slip and scratch or break the face of the type. In some offices their use is prohibited. If their use is confined to open matter allowing a good grip, such as advertisements, they can be employed to good advantage, but the utmost care must be taken when using them. The bodkin

is used to lift up letters, words or lines, so that changes can be made with the fingers. In substituting letters, see that the changes do not alter the justification; if it does, the spacing must be changed. When changes require a new arrangement of the line or lines it is best to lift into the composing stick, justifying being more easily and quickly done. When all corrections have been made, a *revised* proof is taken which should be compared with the first to ascertain that all corrections have been made, and made correctly, and that no errors still exist which were not discovered in the first reading.

For the rules for punctuation and spelling, consult any standard book on language and the dictionary. In this connection it may be stated that the prevailing practice is to use as few marks as will permit of a cor-

rect understanding of the matter. In advertisements the style in some offices is to omit marks at the ends of lines. A study of the popular magazines will show this clearly.

PROOF SHOWING CORRECTIONS.

CORRECTED PROOF.

Hints that are worth looking over. *2 leads*

ole A REPUTATION for promptness is one of the things that a job printer should strive for. *#/* He will have gained a great ~~a great~~ advantage when it comes to be said of him that he *x* ~~get work~~ always *to S/* ~~but~~ on time, and it will pay him to endeavor to secure such a reputation by every means in his power. *4/* I know how *of* ~~valuable~~ the ordinary business man to wait until he is entirely out of stationary, or whatever he wants, before ordering more, or to postpone until the latest possible moment the order for circulars, or hand bills or any bit of commercial work; and then, when he does give you the order, he acts very much as though he thought this was the only work you had in your shop, that you should immediately give him precedence over everybody else. *wf/* If your office is run systematically, you can tell after a moment's reflection just how the work is getting on, and what chances there are for getting a new job started in *lead* Then you can tell your customer when he can have his work, within an hour or two, unless it is a job of considerable magnitude. *x* Then, if he says that is too late, tell him you are sorry, but you would rather lose the order than disappoint him in the delivery of it. Explain the situation to him, and it is ten chances to one he will leave the order. *2/*

HINTS WORTH LOOKING OVER.

A reputation for promptness is one of the things that a job printer should strive for. He will have gained a great advantage when it comes to be said of him that he always gets work out on time, and it will pay him to endeavor to secure such a reputation by every means in his power. I know how prone is the ordinary business man to wait until he is entirely out of stationary, or whatever he wants, before ordering more, or to postpone until the latest possible moment the order for circulars, or handbills or any bit of commercial work; and then, when he does give you the order, he acts very much as though he thought this was the only work you had in your shop, that you should immediately give him precedence over everybody else.

If your office is run systematically, you can tell after a moment's reflection just how the work is getting on, and what chances there are for getting a new job started in. Then you can tell your customer when he can have his work, within an hour or two, unless it is a job of considerable magnitude. Then, if he says that is too late, tell him you are sorry, but you would rather lose the order than disappoint him in the delivery of it. Explain the situation to him, and it is ten chances to one he will leave the order.

HOW TO BUILD A SAIL-BOAT.

CARL H. CLARK.

IV. Fitting the Deck and Cabin.

Fitting the step for the mast will be the next thing to do, as it is more easily done now than after the deck is laid. This step is a piece of oak, or other hard wood, about 5" wide and 4" thick, and long enough to cover the distance from the stem to the centreboard logs. Its forward end is cut to fit over the end of the stem, and the after end should be fitted down between the centreboard logs. Notches are cut in it for the floors, and it fits down solidly on the keel. It probably cannot be bolted now as the foundation is in the way. The holes should, however, be bored and the bolts driven later. The bolt at the forward end passes through the end of the stem.

The clamp streak is next to be fitted. It is about 2 3/4" x 2" amidships, and is tapered at the ends to about 2" x 2". It runs from the inside of the stem to the sternboard, being riveted to the frames 1 1/2" down from the top, to allow the deck beam to rest upon it. It should be fastened with 3/4" or 5-16" rivets driven from the outside, with the head countersunk and headed over a washer on the inside. Where these clamps come together at the stem they should be joined together, and a three cornered piece worked on top of them and riveted through; the top of this piece should be flush with the top strake so that the deck plank will lie upon it. See Figs. 13 and 14.

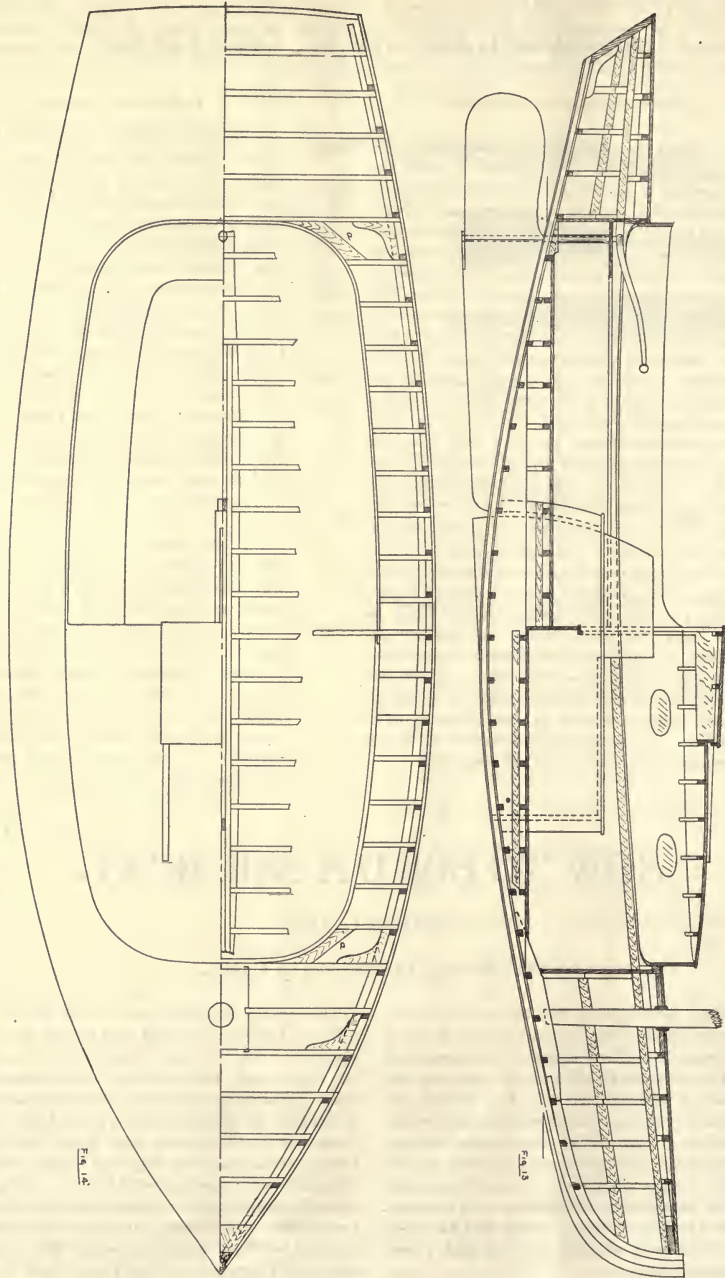

Fig. 15

Fig. 16

At the sternboard a knee or corner brace should be shaped to fasten it securely. At the same time a knee should be fitted to fasten the bilge stringer to the sternboard. The plan, as shown, includes a small cabin large enough for two persons to sleep in. It is not, however, necessary that this cabin should be built, as if desired, it may be omitted, and the coaming carried around forward and the boat left open. If the latter method is adopted, the forward end of the standing room should be just at the end of the centreboard casing. The forward upright should be left long and be fastened to the deck above as a support both to it and to the deck. The coaming should be figured to fasten on the after side of this upright.

The frame. This is not customary, but is considered advisable as making a rather stronger piece of work. The partial beams along the cabin and standing room may have their inner ends supported temporarily by a ribband placed along under them and shored up from below until the deck is laid and they are self supporting. The heavy beam at the after end of the house should extend across the boat, and be cut out later to allow access to the cabin. The three heavy beams at the forward and aft ends of the house, and the after end of standing room, are to be placed $\frac{1}{4}$ " away from the frame, a small piece of $\frac{1}{4}$ " stock being placed between them and the frame.

The beam which is cut by the mast is mortised into a piece of $1\frac{1}{4}$ " plank running from beam to beam, as

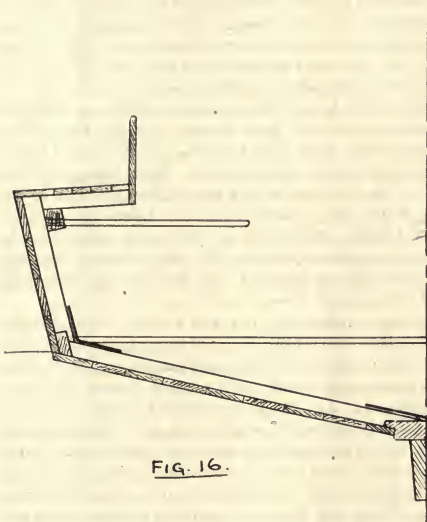

Fig. 16.

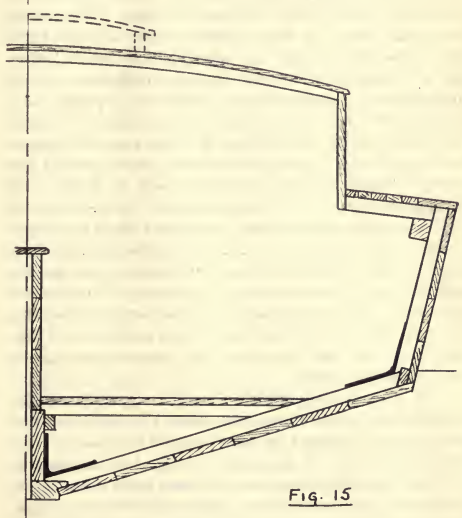

Fig. 15

The consideration of this point is necessary at this time, as the deck beams are the next thing to be put into place and the cabin calls for a different arrangement than if without it. With a cabin the work is as follows;—The deck beams are $1\frac{1}{2}$ " x $1\frac{1}{4}$ " and are tapered at the ends to $1\frac{1}{4}$ " x $1\frac{1}{4}$ ". They are cut with a "camber" or round up of 4" in 7 $\frac{1}{4}$ ". All the beams are cut to the same curvatures and the under side is tapered off towards the ends. The beams forward, are laid against the after side of the frame, and those aft are laid against the forward side of the frame, resting upon the clampstrake.

The beam at the forward and after ends of the house and the one at the after end of the standing room are 2" x 2". The beams rest upon the clamp strake, which is beveled off, if necessary, to give them a good bearing. They are then riveted or bolted to it with $\frac{1}{2}$ " rivets. It is also advised that a large nail or a rivet be driven through the end of the beam and the end of

shown in Fig. 14. This plank is 8" wide and has its ends halved to fit corresponding rabbets formed in the beams. These rabbets must not be very deep as they take away from the strength of the beam. The plank is to be fastened to the beams by rivets or screws. This plank also helps to support the mast and needs, therefore, to be well fastened. For cutting these beams a pattern can be laid out and used for all, regardless of their length. The curvature is supposed to be the arc of a circle, but by careful work, a batten can be bent to give the curve sufficient accuracy.

There are three deck knees on each side, worked as shown in Fig. 14. They are placed against the beam and on top of the clamp strake and fastened with rivets. A piece of wood should also be placed between them, and the side planking, and a couple of rivets put through. The office of these knees is to strengthen the deck structure, and prevent the boat from twisting or wringing. Before laying the deck the bulkheads

at the forward end of the cabin, and the after end of the standing room, should be set up, as it is much easier to do it now than later. The partitions are of $\frac{1}{2}$ " matched stock. There should be just space for each board to fasten to the after side of the frame at the bottom, and to the forward side of the beam at the top. The several boards should be nicely fitted to the outline of the frame, and strongly nailed, as these bulkheads are a very valuable stiffener to the boat and help to keep her in shape. An opening should be left in each, to be fitted later with a door.

The deck is $\frac{3}{4}$ " thick. It may be either covered with canvas, or left bright and varnished as preferred; the former is most easily kept in order, but the latter adds greatly to the appearance, although it requires some attention to keep in good condition. The description of the canvassed deck will first be given. The planking should start at the middle, where a single wide board should be used. It should be about 12" wide and $\frac{7}{8}$ " thick, as it has to be cut for the mast hole. Tongued and grooved stock of pine is to be recommended for the remainder of the decking. It is laid with the beaded side down, to leave a smooth upper surface, as any ridges are likely to cause wear of the canvas. Small headed nails are used to fasten the decking, and they are driven or set below the surface. At the edges the decking is finished off to the curve of the sheer strake and strongly nailed to its edge. The decking must make as good a joint as possible with the top strake, as any leak here will show when she heels over under sail. At the stern, also, the plank is trimmed off even with its after surface. The stock for the deck should in any case be thoroughly dry and well seasoned.

If the deck is to be finished bright, an oak board 9" wide, and $\frac{3}{4}$ " thick is first laid down the middle of the deck forward, joined to the stem and fastened to the triangular pieces of plank forward and to each beam. All the deck fastenings in this case must be counter-bored for and afterwards plugged with wooden bungs. The plankshears, or covering boards, are 3" wide, and $\frac{3}{4}$ " thick, and are bent around the outside of the deck and fastened to each beam and to the edge of the top strake. At the bow a miter joint is made with the middle plank, as shown in Fig. 14. These boards will require steaming. A piece 3 $\frac{1}{2}$ " wide is also fitted across the stern making a miter joint with the covering board. To support the latter piece and also the ends of the plank at the stern, a ledge must be formed of pieces fastened on to the sternboard.

The planks in this case are of white pine $\frac{1}{2}$ " thick, and are very narrow, about 2". They are bent around inside the covering board, and fastened to deck beams and the ledges at the ends. Pieces are nailed to the underside of the middle plank between beams to take the ends of the plank. The edges are beveled just slightly near the top surface to allow the insertion of calking, but below, they should be close together. After the deck is laid, the opening for the cabin and

standing room should be trimmed out. The clear space of deck around them is 12" and it is parallel with the outside of the deck. The ends of the short deck beams may be cut off evenly, and the short pieces *a*, Fig. 14, may be fitted and nailed to beams and deck; these pieces are to strengthen the house at the corners and allow a good fastening. The deck is to be canvassed later, after the coamings are in place.

The cabin trunk is of oak $\frac{1}{4}$ " thick and 13" wide. It will probably be necessary to make a joint on the forward end which should be done by halving the two pieces. The fitting and bending of this trunk is a rather fussy piece of work. A form should be made to bend it over, and it should be thoroughly steamed before bending is attempted. It will be well to bend the two pieces for the trunk some time before they are wanted so that they may have time to become thoroughly set into shape, and bring no strain upon the boat by any tendency to open out. They may then be used as a pattern by which to cut out the deck and thus make the fitting easier.

The lower edge of the trunk is to be even with the lower edge of the deck beams. At the after end it extends even with the after face of the heavy beam, being notched to fit around it. It is fastened to the end of each beam with a long screw, and also to the edge of the deck plank near each beam and once between beams. The sides of the trunk should not be perfectly vertical, but should slope inward slightly. The joint on the forward end is a halved joint fastened with copper rivets.

The port lights in the trunk are not to be cut until later, after everything has set into place. The stock for trunk must not be too well seasoned, as it is then somewhat brittle and apt to break when bent to a sharp curve. As soon as the water from steaming has evaporated, it should be given a heavy coat of oil, and when this has soaked in a coat of shellac both inside and out to keep the air out and prevent checking. The wash rail or coaming should next be bent into place. This will be much easier to fit than the trunk sides. It is of oak $\frac{3}{4}$ " thick and 9" wide. Where it meets the trunk, the end should be cut down to about 9-16" thick and allowed to lap on to the outside of the trunk, the latter being cut out for this purpose. It is fastened with brass screws. The joint between the pieces forming this coaming may be either at the after end, using two pieces, or on the sides, using two short pieces and one long one. This latter is to be preferred, as the joints can be covered on the outside with a block which is convenient to take a rowlock socket later. The upper edge is rounded and it is treated with oil and shellac as with the trunk.

All the fastenings in the coaming and trunk should be counterbored and afterwards plugged with bungs so that they may be finished bright if desired. In order to give the forward end of the coaming the curve up to the height of the house side, as shown in Fig. 13 and Fig. 1, a curved piece is cut and fitted on the top

of it, and fastened to the house side in the same manner as the coaming. The beams for the top of the cabin house are $1\frac{1}{2}'' \times \frac{3}{4}''$ oak, and are cut with a round up of $5''$ in the width of the house. The after face of the aftermost beam should be directly over the after face of the strong beam below. The beams should be spaced about $8''$ on centres. If a beading tool is at hand, a bead can be cut on the lower edges of each beam, giving a little finish. The ends of the beams are dove-tailed and fitted into a corresponding dove-tail in the trunk side. The dove-tail should not come through so as to show from the outside. A nail may also be driven in the end of each beam.

The top is of $\frac{1}{2}''$ tongued and grooved sheathing, laid smooth side up and nailed to the beams and the trunk side. Its edge is smoothed off even with the side of the trunk. Before undertaking to cover the deck and housetop with canvas, all ridges and sharp points should be trimmed. The top of the house and the deck may now be covered with canvas, heavy drill or light duck being suitable for this purpose. It can usually be obtained in almost any width, thus avoiding seams, which soon wear out. The piece for the house top is in a single width, while that for the deck is in two pieces, each covering a side and lapping on to the centre plank, which is not covered. The edge of the centre plank is beveled off to the level of the adjacent plank, or still better, cut out square for a distance of about $\frac{3}{8}''$ or $\frac{1}{2}''$ back to take the edge of the canvas. The opening for the house and cockpit is first cut approximately to shape.

The forward end of the deck is smeared with thick lead paint, and the selvage edge of the canvas is tacked along in the depression or rabbet which was cut in the middle plank. The tacks used should be of copper driven about $\frac{1}{2}''$ apart, and the canvas should be drawn tight. After tacking the middle seam the canvas is drawn tightly over the edge of the deck, and a row of tacks driven around the edge. When the trunk is reached the canvas should be trimmed out and fitted carefully around it, a row of tacks driven as close to it as possible, and a flap an inch or so wide allowed to remain. This is continued all the way aft taking care to draw the cloth tightly and keep out all wrinkles. The deck is of course heavily coated with the paint before laying the canvas. On the after deck it is treated the same as on the forward deck. A strip of oak $1\frac{1}{2}'' \times \frac{3}{8}''$ is now fastened over the outer edge of the canvas about $\frac{1}{4}''$ back from the edge of the deck, and the canvas is trimmed off even with its outside edge. This gives a finish and also keeps the edge of the canvas tight.

A quarter round moulding is also fitted against the cabin trunk and coaming. The corner under the canvas should be well filled with paint and the moulding fastened tightly against the house to keep out rain and spray. The top of the cabin is covered in the same manner, the canvas being turned down over the edge and tacked. A $\frac{1}{2}''$ oak half round moulding is bent around the house and across the after end, and the

cauvas trimmed off to it. The centreboard box can now be completed. It is of $\frac{1}{2}''$ well seasoned stock, and is fastened with light rivets. The uprights, and the inside of the boards are given a thick coat of paint, and a thread of cotton is laid against the sides of the uprights before putting the boards in place. The boards should be rather narrow and each one should have several $\frac{1}{4}''$ rods extending down through it into the one below to strengthen the whole. The top should be about $12''$ above the waterline. The uprights should now be cut off even with the sides, except where no cabin is fitted and the forward one extends to the deck.

A MODEL STEAMBOAT. Cont'd.

and running from the valve on the boiler to the steam inlet on the engine or turbine.

The means for feeding the boiler next requires attention. A small pump is to be used, run by a belt from the shaft of the engine. This means is suggested, as the adjustment of the pump to give the correct amount of feed must be done by trial, and by varying the sizes of the pulleys driving the pump. After it is once adjusted it will be nearly automatic for all speeds of the engine. This feed pump draws from a tank which is placed in some convenient part of the boat and discharges into the boiler through the feed pipe before mentioned. The pump must be so adjusted as to maintain the water level at the point marked, and neither flood the boiler, nor allow it to run dry, as the latter is a source of great danger. The tank should be of fairly large capacity, as the steam is thrown away after passing through the engine. The pipes for the feed pump can be about $\frac{1}{2}''$ diameter.

For the burner, a rather large alcohol lamp is needed. There are several ways of making these, but the simplest is as follows. A sort of pan is made about $4''$ long, $2\frac{1}{2}''$ wide and $\frac{3}{8}''$ deep with flaring sides. It rests in the furnace just below the centre with short legs to keep it away from the furnace side and admit air around it. From this pan a $\frac{1}{2}''$ pipe leads to the reservoir of alcohol several inches away. This pipe has a cock or valve in it to regulate the supply of alcohol. The pan is now filled nearly full of asbestos wool, and a piece of wire gauge is set on top to keep it in place. A shield is to be arranged to cover the mouth of the furnace and prevent the flame coming out. Air must however, be freely admitted both above and below the lamp. If the burner smokes it shows that too much alcohol is being used for the amount of air present.

It will probably be found that on first starting up the boiler the draft will be poor and some means must be taken to accelerate it, either by passing or exposing to a brisk wind, but after the boiler and stack become warm, no trouble should be found. The exhaust from the engine may be carried into the stack and made to assist the draft. If desired, a whistle and other accessories may be fitted.

JUNIOR DEPARTMENT

For the Instruction and Information of Younger Readers.

ELEMENTARY MECHANICS.

J. A. COOLIDGE.

III. The Inclined Plane.

We will next study the construction, uses, and advantages of the inclined plane. Next to the lever this is the simplest of the mechanical powers, and a machine that we can hardly fail to see in walking five minutes about the business portion of a large city.

The board used in our experiments in friction can be used once more. It should be a piece of clear pine board, 3' long, 6" wide, and $\frac{3}{8}$ " thick. We must cut a piece $\frac{3}{4}$ " wide and 2 $\frac{1}{2}$ ' long out of the middle of the board. See Fig. 6. Next we must have two strips of wood, $\frac{5}{8}$ " thick, 24" long, and 3" wide, with a slot $\frac{3}{8}$ " wide cut out of the middle to within 1 $\frac{1}{2}$ " of each end. See Fig. 7. These will serve as supports for the upper end of

two pieces of curtain pole or other round stick at least 1 $\frac{1}{2}$ " in diameter, 2 $\frac{3}{4}$ " long, and polish as smooth as possible. Through the length of these pieces, exactly in the centre, bore a hole $\frac{1}{4}$ " in diameter. Or large spools may be used by carefully cutting off the bevel ends, only they must be smoothly rounded. Two pieces of $\frac{1}{4}$ " brass rod, which can be got with the curtain pole of any furniture dealer, must be cut 3 $\frac{5}{8}$ " long. These may be made to serve as axles for the rollers by dropping a little shellac into the holes of the wooden rollers and then pushing the rods through. See Fig. 9. Two narrow pieces $\frac{5}{8}$ " thick, 5" long and 3 $\frac{1}{2}$ " wide will next be needed; $\frac{3}{4}$ " from each end, and $\frac{1}{2}$ " from one edge, bore

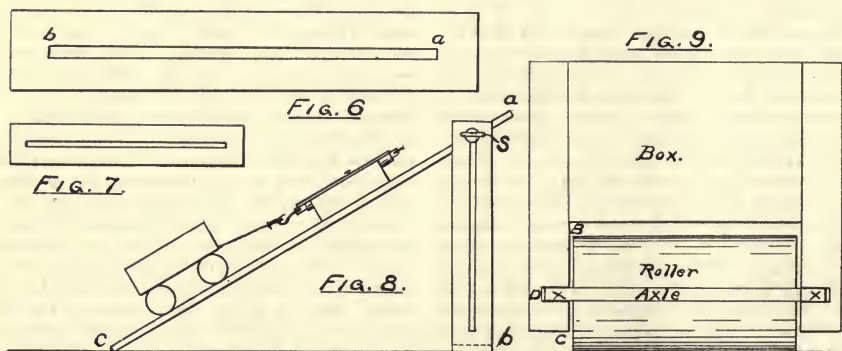

our board *A*, and should be fastened by two screw-eyes *S*, that fit into *A* and are prevented from pulling through the slots by tightly fitting washers. See Fig. 8. The lower end of the strips may be kept in place at *b*, by nailing them to a strip of wood 6" long and 3" wide.

Now we must make a little car which shall run with very little friction, a well made toy railway car will answer. With these appliances our experiments ought to be accurate enough to teach us the laws of the inclined plane. A small wooden box 5" x 3" and 2" deep should be made of $\frac{3}{8}$ " stock and mounted on two rollers as wheels. Cut

holes $\frac{5}{16}$ " diameter and $\frac{3}{8}$ " deep. See *D*, Fig. 9. These holes must be made as smooth as possible and lubricated with powdered graphite. Our axles, *X X*, Fig. 9, will fit easily in these holes and should turn with but little friction. After fitting these in the holes, tack or glue the strips to the sides of the box and we have a car which, though crude, will serve our purpose very nearly as well as a more expensive one.

Before studying the laws of the inclined plane, one or two experiments in friction must be performed, and in all experiments allowance should be made for the force lost in overcoming the

<i>a b</i>	Total Wt.	Total Force	Friction	F less Friction	$P \times L$	Wt. x H
12 in.	2 lbs.	"	"	"	"	"
"	3 lbs.	"	"	"	"	"
"	4 lbs.	"	"	"	"	"
<i>a b</i> 18 in.	2 lbs.	"	"	"	"	"
"	3 lbs.	"	"	"	"	"
"	4 lbs.	"	"	"	"	"
<i>a b</i> 24 in.	2 lbs.	"	"	"	"	"
"	3 lbs.	"	"	"	"	"
"	4 lbs.	"	"	"	"	"

friction, and not directly available in moving the weight we wish to raise.

EXPERIMENT XI.

Take the block used in the experiments in friction, draw it along the board five or six times. Divide the force used to move the block by the weight of the block. This, as you know, is the co-efficient of friction. Raise the end of the board *A C*, Fig. 8; place the block on the board and adjust the height *a*, until the block will just slide down with uniform speed. Great care must be taken that the block does not move with increasing speed. Measure carefully the height *a b* and call it *h*; also the base *a c* and call it *b*. Divide *h* by *b* and the quotient, *h* divided by *b*, is the coefficient of friction and should be the same as that found before, although found in a different way. Let us suppose this is about $\frac{2}{30}$. Whatever it is, that fractional part of the force used should be deducted on all experiments with the block, on account of friction, the remainder is available in moving the body.

EXPERIMENT XII.

Place upon the block weights enough to make the entire weight 30 ounces, and pull it up the board *a c* several times until we have determined accurately the average force employed in moving it. Deduct the force used in overcoming friction, and we have *W*, the weight, and *F*, the force. Measure the height *a b* and the slant *a c*. See Fig. 8. Multiply *F* by length *a c*. Multiply *W* by height *a b*. Do they agree? They should. By the law of the inclined plane, "Power x Length = Weight x Height." Make the height *a b* less than before and try the experiment again.

EXPERIMENT XIII.

With the board horizontal find the friction in pulling the little car with a total load, car and weights, of 2 lbs. Raise the end of the board *a* 12" above *b* and try again. Increase *a b* to 18" and then as high as possible, in each case determining the force, after deducting the friction. It is very easy to see in a general way that the steeper the slant the greater the force. We will now try the experiment more systematically, and arrange our results so that we can see what the experiment teaches.

Does the law $P \times L = W \times H$ hold true?

Can you not, as you compare the force and weight, see how barrels are rolled up inclined planes? Think of the skids and planks on all the trucks. Every large team carrying barrels and bales of merchandise has one hanging on one side or underneath. But why is this possible? After taking out friction, which must be overcome in moving the car even over a horizontal surface, we find 1 lb. force moving 3 lbs. weight. In considering the object to be attained we find that it is to lift a weight the distance *a b*, or a barrel of sugar into a wagon, let us say. The weight has to be slid or rolled the length *a c*, or up an incline three or four times as long.

The weight lifted may be considered as a force acting against the moving force, and it may be separated into two forces, or two results. One effect of the weight is to bend the inclined plane, as can be seen when a very heavy weight is resting on a plank. This effect, or force, is overcome or met by the stiffness of the plane. The other effect of the weight is to roll or slide down the plane. The force that is used in moving the weight up the plane overcomes this force. The nearer horizontal the plane is, the nearer the force necessary to move the weight is to zero. The force is always as many times less than the weight as the height is times less than the length.

EXPERIMENT XIV.

It now remains to move the car with a force parallel to the base *b c*. Fasten the car to the hook of the balance by a long thread, pass the thread through the slot in the board and pull the loaded car up the incline *a c*, keeping the string and balance always horizontal. At first this will be awkward, but after a few trials we can obtain a satisfactory result. Measure *a b* and *b c*. Try $F \times X \ b c$ and $W \times X \ a b$. How do these products agree? We should find the results correspond as before, but the reason is not so easily seen. Perhaps it will be enough to know that it is true. Questions of forces pulling wagons up a hill, or loaded cars up a track can now be answered. In all cases the gain in moving a large weight with a small force is offset by the necessity of making the force act through a correspondingly greater distance.

ELECTRICITY BY EXPERIMENT.

II. Magntic Field.

The space surrounding a magnet over which the magnetic forces extend is known as the *magnetic field*. It is desirable to learn fully the direction and form taken by these magnetic lines of force, which we can easily do with the two bar magnets and iron filings used in the previous experiments. A sheet of thin, firm writing paper is glued to a wooden frame, made of strips of wood $\frac{1}{2}$ " thick. The frame keeps the paper firmly stretched and free from wrinkles,

EXPERIMENT 6.

Place the frame over a bar magnet, the latter just touching the under side of the paper. Sift the iron filings over paper, at the same time lightly tapping the frame with a small weight. The filings will be seen to arrange themselves in certain curves, thus producing a graphic illustration of the magnetic lines of force, or magnetic field surrounding the magnet.

EXPERIMENT 7.

Place the second bar magnet parallel with the other, and about 1 $\frac{1}{2}$ " from it, with the N pole of one magnet at the same end as the S pole of the other magnet. Again sprinkle the iron filings on the paper as before, and study the curves formed by the filings. Place the two N poles at the same end, and study the curves formed by the filings.

These experiments are important and should be made carefully and a sufficient number of times to firmly fix in the mind of the student, the action of the magnetic field under the several conditions of polarity above mentioned. A photographic record can be made by using a developing paper, arranging the filings by light from a ruby lantern and then exposing to white light and developing.

Another way is to use wax coated paper, upon which the filings are arranged, then heating the wax with a lamp held underneath at a proper distance to soften the wax sufficiently to allow the filings to embed themselves therein; the wax quickly hardens upon withdrawing the lamp, firmly fixing the filings in position. Care must be taken not to ignite the wax or heat it to the extent that it will melt and drop into the lamp. Another way is to use gumed paper. When the filings are arranged, moisten the paper with spray from a vaporizer, then dry quickly over a stone.

HOW BOYS CAN EARN MONEY.

I. FLOWER SEEDS AND FERTILIZERS.

A good business to be carried on with a small capital is that of selling flower and garden seeds and fertilizers. This business, although it can only be carried on in the spring, gives good profits while it lasts. First write to the nearest wholesale seed dealers who have a good standing for reliable goods. Tell

the dealers what you propose to do, and ask for catalogues and what discounts from the catalogue prices prices they will make to you. Then get a supply of catalogues from the dealer you decide to order from. Next call on your proposed customers and leave catalogues with those who promised to give you orders. State when you will call for the orders and catalogues, and then distribute the catalogues with others. As the season is so short, visit as many people as possible as soon as you can. When you have a sufficient number of orders from customers, make out an order and send to the dealer. Have your orders on the dealer as large as possible, so not to pay express charges on too many lots. It convenient, tomato plants may be sold with good profit. The success of this business will depend upon selling seeds that have a known reputation for being reliable.

BOOKS RECEIVED. Cont'd.

LABORATORY PHYSICS. Dayton Clarence Miller. Cloth. 404 pp., 8 $\frac{1}{2}$ x 5 $\frac{1}{2}$, \$2.00 Ginn & Co., Boston.

This is essentially a laboratory manual, in which one hundred and twenty eight well selected exercises are fully and carefully presented. The grade of work is that of the usual undergraduate course in colleges and technical schools and presupposes that the laboratory work will be accompanied by a course of lectures and recitations in general physics. As far as possible the descriptions are independent of any particular form of apparatus, thus making it available with laboratories of varying equipment. The details of manipulation are adequate, and the explanations of the general principles and scientific meaning of the experiments clearly presented. Thirty three tables and 182 illustrations.

OUT DOOR PORTRAITURE. Mathilde Neil, No. 58 Photo-Miniature.

COMBINATION PRINTING. A. Horsly Hinton. No. 59, Photo-Miniature. 25 cents. each, Tennant & Ward, New York.

No one can have been engaged in photographic work for any length of time without learning of the Photo-miniature series. In a form convenient for carrying in the pocket, each number contains a well written presentation of some special feature of photographic work, as well as numerous notes likely to be of interest. This enables the reader to study such branches of work as he may desire without being encumbered with a large book containing much of no interest. The two numbers above mentioned are of particular value, the first to all photographers, and the second to those who have acquired a reasonable degree of manipulating skill.

The Amateur Lathe is easily secured by a little work. Try it.

AMATEUR WORK

A MONTHLY MAGAZINE OF THE USEFUL ARTS AND SCIENCES

Vol. III. No. 7.

BOSTON, MAY, 1904.

One Dollar a Year.

A ROWING SKIFF.

CARL H. CLARK.

The skiff here described is one suitable either for a tender to a yacht, or for pleasure rowing on rivers, lakes, or ocean. This type of boat is very desirable for use in shallow water, as it is of light draft, while the round up of the bottom forward makes landing on a shelving beach very easy. At the same time the boat is very staunch, safe and easy rowing. While not as handsome as a round bottomed boat, it is less expensive, and can be built by any amateur very easily.

The general scheme of construction is quite similar to that of the power dory previously described. The actual work will, however, be much lighter as the stock is not so heavy nor so long. The boat is 14' long on top, 12' long on the bottom, 4' 4" wide on top and 18" deep. It will carry four people comfortably and still be perfectly safe and easy to row. The bottom is built of pine with oak or other hard wood for frames, stem and sternboard. The bottom is $\frac{3}{4}$ " thick, and is laid out from the dimensions to the dotted line in Fig. 2. The lengths for this purpose are given in Fig. 1. It is left about $1\frac{1}{2}$ " wide at the forward end. On account of its width it will require to be made in three pieces; one piece in the middle with a narrow piece on each side being the best arrangement. The joints are planed smooth and even with a slight concavity, so that when forced together the ends will surely be tight, or the edges may be tongued and grooved if carefully done. They are laid on a flat surface and forced together with wedges and fastened on the upper side with cleats 3" wide and $\frac{3}{4}$ " thick. These cleats should be placed midway between the moulds, which are in the positions shown,

and are fastened with strong brass or galvanized iron screws. The bottom should then be beveled off on its under edge, as near as possible to the proper bevel, as it is much easier to do now than when the boat is set up. The centre line and the cross lines should be left on, as they are to be used in setting up the boat.

The stem is a crooked knee about $1\frac{1}{2}$ " thick, cut away to the dimensions shown. As will be seen, the outer piece of the stem is bent in place later, as in the power dory. It is beveled off to about $\frac{1}{2}$ " wide on the forward edge to give a flat bearing for the plank and is fastened to the forward end of the bottom with rivets. The sternboard is of $\frac{7}{8}$ " oak, shaped to the dimensions shown; these dimensions are of the after face, and wood for a considerable bevel should be allowed for to be trimmed up exactly when the plank is put on.

A light knee, shaped as illustrated, is fastened in the corner between the bottom and the sternboard; it holds the latter in place at the proper angle while the plank is being put on. A row of galvanized nails is also driven through the after end of the bottom into the sternboard. The frames or knees are of natural crook, two alike being made for each form shown. They are $\frac{7}{8}$ " thick, 3" wide, and are fastened together in pairs. The centerline should be marked across the foot of the pair and a brace should also be fastened across the top to keep them at the correct width.

The bottom is now supported at its ends on two blocks or horses at about the right height for working, the middle is then forced down $3\frac{3}{4}$ " by shores from the beams above and held in place,

The frames are now set up on the bottom in their proper places, with the joint between the two frames on the line across the bottom, and their centre lines agreeing with the centre line of the bottom. They should be set "plumb" using the plumb glass of a carpenter's level to adjust them. It will be necessary to bevel the heels somewhat to make them set plumb on the sloping bottom. When properly adjusted in place they are fastened from below with brass or galvanized

planks to lie flat upon them. The plank for the other side may be gotten out, using this one as a pattern.

Before fastening in place, the lower edge should be bevelled off nearly right, as it is easier to do this now than after fastening in place. The bevel on the top edge for the next plank above is formed as follows: with a gauge, mark a line on the outer surface $1''$ down from the top edge, and on the top edge a line $\frac{1}{8}''$ in from the

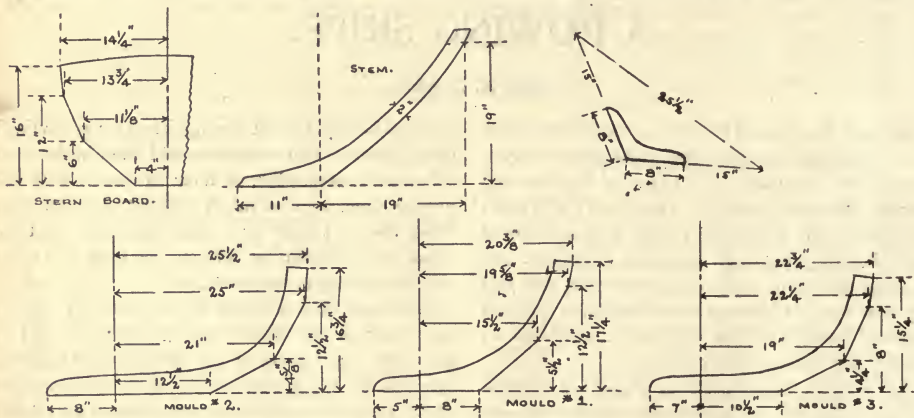

iron screws. The edge of the bottom is then bevelled off to the same bevel as each mould so that a straight edge laid on each mould will lie flat across the edge of the bottom, and the bevel between moulds evened up as nearly as possible.

The plank is of pine $\frac{1}{2}''$ thick; it must be clear, well seasoned and free from knots, especially in wide widths, as there will be some "camber" to the planks, which must be allowed for. The planking is put on, starting with the lower one. A board is bent around the frames and temporarily fastened with clamps; it is then marked about $\frac{1}{4}''$ below the first knuckle of each frame and the sternboard and around the top edge of the bottom. The plank is then taken off and a line drawn through the points near the top to outline the top of the plank. The width of the bevelled edge of the bottom is measured at several places and laid off from the line drawn around the bottom, to get the line of the lower edge of the plank. The plank is then sawed out, laid on again in place and any necessary changes made. The frames will require a slight amount of bevel to allow the

inner surface; the outer corner is then cut off to these two lines; the $\frac{1}{8}''$ on the inner edge avoiding a feather edge. The plank is now to be fastened in place, with the top edge about $\frac{1}{2}''$ down from the knuckles of the frame. It is nailed to each mould with several galvanized iron nails and also to stem and sternboard. The lower edge is now bevelled off even with the bottom and a row of galvanized boat nails driven through the lap about $4''$ apart and clinched on the inside. They should be of proper length to clinch over about $\frac{1}{4}''$; they should be bored for, and driven with the flat of the point along the grain and clinched across the grain. The ends of the plank are trimmed off just beyond the stem and sternboard. The second plank is shaped and fitted in about the same manner. Its lower edge is bevelled to match that on the upper edge of the lower plank, and its upper edge is lined and bevelled as before described. At the forward end both are bevelled off to bring the surfaces flush. Through the lap of the two planks galvanized boat nails are driven as before described.

The top plank is fitted in the same manner and is carried $\frac{3}{4}$ " above the tops of the moulds. The lower edges of the two upper planks are rounded off, and at the ends are smoothed off even with the surfaces of the stem and sternboard. A false piece for the face of the stem is cut out of the proper width to cover the ends of the plank, and rounded off on the forward edge. It is fastened on with screws.

Around the inside of the top strake and on the tops of the frames, gunwales $\frac{3}{4}$ " thick and 3" wide are to be worked; they are tapered at the ends to 2" wide. They are fastened to the tops of the frames and to the top strake; at the stern they are fitted neatly against the sternboard and a small knee riveted in. At the bow they are fitted to the inside of the stem and a V shaped knee or breast hook is worked between them and fastened with rivets.

The top of the stem is rounded off as shown, and a $\frac{1}{2}$ " hole bored for the painter. The top of the sternboard also is neatly curved and the edges rounded. The skag is of $\frac{3}{4}$ " oak, 4" deep at the after end, tapering off to about $\frac{1}{4}$ "; it fits the after curve of the bottom and is fastened by nails driven through from the inside. The skag, while not always necessary, makes the boat row more steadily. The strips which supports the seats are $2\frac{1}{2}$ " x $\frac{3}{4}$ " bent around inside the frames 6" down from and parallel with the gunwale. At the ends they are fastened to cleats. The upper edge is beveled off to allow the seats to lie flat. The seats are located as shown, and rest upon the strips just mentioned; the after seat is about 15" wide. When located in this way she will trim with either one, two, three or four passengers. The rowlocks are to be set into blocks on the gunwale as shown, 8" long,

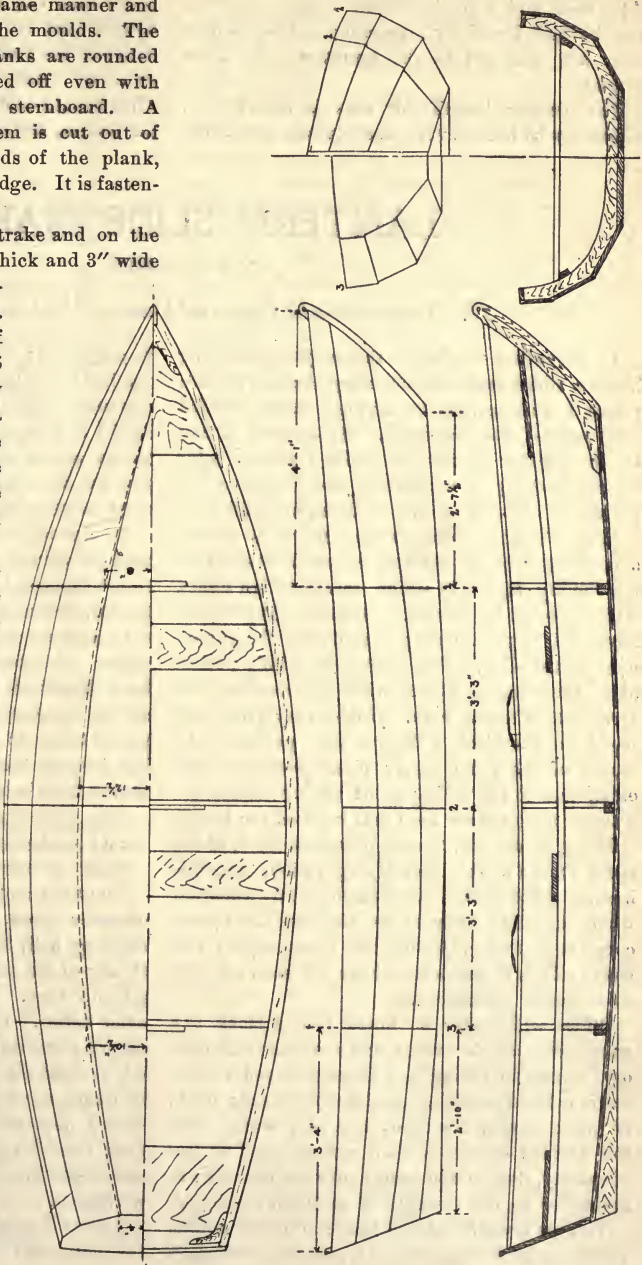

2½" wide and 1 thick. Their correct position can be best found by experiment, after which they are fastened to the gunwale with brass screws.

The proper length for oars is about 8 ft. These can be bought very cheaply and are much

better than can be made by the amateur. The bottom may be left clear or fitted with gratings between the frames. They are made of narrow strips ½" thick, nailed on to the cross pieces. They should come about to the level of the top of the frames, and are easily removed for cleaning.

LANTERN SLIDE MAKING.

R. G. HARRIS.

IV. Toning with Gold, Copper and Uranium — Reducing and Intensifying.

In preparing to discuss the subject of toning lantern slides made on ordinary gelatine lantern plates, I must confess to having a rather decided bias against the operation. My opinion is that the finest slides are those in which the exact color is obtained by development, and I believe experienced workers incline to the same opinion.

When toning lantern slides there is always some danger of the gelatine becoming stained by the toning agent; in which case the high lights, which should be absolutely transparent gelatine, have their original purity degraded by the ground color of the slide. This fault is especially noticeable when toning slides with the uranium and ferricyanide toning bath. Unless very great care has been exercised a brown tint pervades the whole of the slide where clear gelatine should exist, due to the toning agent having stained the gelatine at the same time that it toned the image.

Many, if not all, toning processes have, at the same time, a slight intensifying action, and this intensification makes itself unpleasantly apparent when the slide dries, as the shadows usually become very heavy, losing the transparency one usually finds in slides that have not been subjected to toning operations.

Slides will either be toned from a black to a warm color or vice versa, and the most satisfactory results in toning are those obtained when a warm colored image is toned down towards black. If black images are toned to a very warm color the decided change is often accompanied by loss of quality, due to the length of time occupied in toning, or to the strength of solutions employed.

To tone a warm colored image to darker colors, platinum, gold sulphocyanide, and palladium may

be employed; while to tone a black image redder, one has to employ either copper or uranium ferricyanide, unless the image is converted into some haloid and again developed. Of these various toning agents the platinum bath for dark colors and the ferricyanide for warm colors are the most satisfactory.

A sulphocyanide toning bath, similar to that used for prints, may be employed to tone a warm colored image, but the color of the slide, if toned too far, becomes purplish black, and it is questionable whether such a color looks well in lantern slides. "Photographic purples" as they have been described, are best confined to silver prints, as the instances in which they suit the subject rarely occur in lantern slide work. The following formula may be used when a sulphocyanide toning bath is wanted.

Ammonium Sulpho-cyanide, 60 grains.
Gold tri-chloride, 5 grains.
Water, 16 ounces.

The gold should be dissolved in half the amount of water given, and the sulphocyanide in the remaining half, the solution of gold being added slowly to the sulphocyanide solution, stirring this all the time. Some form of platinum behaves even better. It should be noted that potassium chloro-platinite is the particular salt recommended, and not platinum bichloride. This latter salt is often quite acid with hydrochloric acid, and requires neutralizing first with some alkali and then reacidifying with nitric acid. If potassium chloro-platinite is used, no trouble will be experienced.

I have found that the formula usually given for platinum toning baths are too weak, requiring

an inconveniently long time before any marked change is effected. The following bath is much more concentrated than usually recommended, but gives very good results in my hands:

Potassium Chloro-platinite, 5 grains.
 Gold tri-chloride, 5 grains.
 Hydrochloric Acid, 10 minims.
 Water, 5 ounces.

Platinum toning, if carried very far, intensifies the image slightly, so that should an attempt be made to tone a red colored slide quite black the slide might be found worthless on drying from the adventitious opacity acquired in toning. The most suitable slide for toning is one devoid of any great shadow masses, and one which wants just a little additional density to make it a perfect slide. The following modification of the gold-platinum bath is very convenient, as with it the increase of density is scarcely noticeable:

Sodium Phosphate, 50 grains.
 Gold tri-chloride, 5 grains.
 Potassium Chloro-Platinite, 5 grain.
 Water, 5 ounces.

The bath must be used fresh, and will not keep. Toning with it is very rapid, but a pure black color is not readily procurable. Toning slides from black to warm is less easy than the foregoing, besides the alteration of color. Copper toning appears to give better results than uranium, as the staining of the gelatine previously referred to when speaking of uranium toning does not take place. Mr. Ferguson, who has done a large amount of experimental work in copper toning, recommends ten per solutions of copper sulphate, potassium ferricyanide, and neutral potassium citrate. To prepare toning bath we take:

Cupric Sulphate (10 per cent solution), 140 minims.
 Potassium Ferricyanide (10 per cent solution) 120 m.
 Potassium Citrate (neutral) 10 per cent ") 4 ounces.

The potassium citrate is added to the copper sulphate, and then the potassium ferricyanide is poured in, when a clear green solution results, which keeps well and tones readily, without staining, from purple black to red. Uranium is less satisfactory than copper owing to its liability to stain. As, however, beautiful results can be obtained with careful working, by the process. I do not feel justified in excluding it from notice. The exact strength does not seem of much importance, a stronger solution merely working

quicker. The following is a convenient strength.

Potassium Ferricyanide, 5 grains.
 Uranium Nitrate, 5 grains.
 Acetic Acid (glacial) 1 ½ drams.
 Water, 2 ounces.

After toning, the slide is washed in running water for about ten minutes. Care has to be taken not to wash too long, otherwise the brown color is washed out, leaving the image in a very unsatisfactory condition. Uranium toned slides should be varnished when dry to prevent fading.

A very pleasant bluish green color may be given to a lantern slide that has been toned with the uranium toning bath if it is well washed and immersed in the following:

Hydrochloric Acid, 20 grains.
 Iron Perchloride solution, 10 minims.
 Water, 5 ounces.

The color obtained is very suitable for foliage subjects, but as the gelatine is stained throughout the slide any subjects with masses of high lights do not look well. The green color, however, can be discharged from any portion of the slide by treating it with a weak solution (say twenty per cent) of ammonia. Thus, the sky portion, where the stain shows more objectionably, can be cleared. Again, a slide, having been toned brown with uranium, can have certain portions of it toned green by applying with a camel hair brush the iron solution given previously; in this way a slide with two colors results, and some subjects look very effective when done in this manner.

In spite of the variety of results that can be obtained by toning methods, I would urge upon the lantern slide worker to devote all his care to gaining a high class slide by the unsophisticated process of development. Reducing and intensifying methods are of greater importance than toning formula. However expert and careful one may be, a certain proportion of his work will always be the better for re-adjustment in one direction or the other. Either some portion of the slide is over-dense and requires reduction locally, or the whole slide would be better for just a trifle more opacity. Lantern slides, unlike negatives, require their opacity to be exact, or the effect when they are projected upon the screen is unsatisfactory.

The reducer introduced by Mr. H. Farmer is particularly useful in slide work if not used too strong. One and a half grains to the ounce is

quite strong enough, though for local reductions of dense portions this may be slightly exceeded. The most convenient way of making up this reducer is to keep a ten per cent solution of the potassium ferricyanide made up, and to add ten or twenty minims of this to each ounce of water. The amount of hyposulphite left in the film and upon the surface of the plate when it is removed from the fixing bath is quite sufficient to effect reduction, though after reduction and a good rinse the plate may be replaced in the fixing bath for some minutes with advantage.

A good lantern plate with suitable developer should, on being removed from the fixing bath, show perfect freedom from any surface marks or deposit, except that which forms the image. Occasionally when developing for warm colors, an irregular white deposit occurs on the film. This may be removed by washing and rubbing slightly with a tuft of cotton wool, but the ferricyanide reducer is much simpler and safer. A weak solution is flowed over the plate two or three times, just long enough to remove the deposit without reducing the image. A reliable intensifier is especially useful when making slides having warm colors, as these slides are not easy to obtain of the exact density. The following formula may be relied upon to give perfectly satisfactory results without the least influence upon the color.

- A. Hydrokinone, 20 grains.
Citric Acid, 20 grains.
Distilled water, 20 ounces.
- B. Silver nitrate, 20 grains.
Nitric Acid, 5 minims.
Distilled water. 20 ounces.

Equal parts are taken to form the intensifier. The plate should be well washed after fixing and placed for some minutes in an alum bath, and again well washed before intensification. As the intensified slide, when dry, is somewhat denser than it appears when wet, allowance must be made for this and intensification stopped somewhat short of the required degree. The plate is rinsed thoroughly under the tap after intensifying and placed in the fixing bath for a short time to remove any silver chloride that may have been precipitated in the film. Another intensifier of considerable value to the lantern slide maker is that of M. M. Lumiere. The formula is:

- Sodium Sulphite, 1 $\frac{1}{2}$ ounces.
Mercuric Iodide, 20 grains.
Water, 6 ounces.

The slide on leaving the fixing bath is well rinsed and flowed over with the above intensifier when density soon accrues. After a good washing, the slide is redeveloped with some developer such as amidol, etc.

Photography.

A LANTERN SLIDE HOLDER.

E. E. MESSENGER.

The lantern slide holder here described presents several advantages over any other which I have ever seen. It is compact, easily worked, and all slide are, when in position, in exact focus, which is not the case with holders having parallel ways, as with the latter either one or both slides must be slightly out of focus. With this holder the slide is carried in the front groove to the opening, then carried back into the back groove, where it remains during exposure, then withdrawn by the back groove.

The material required to make it consist of the wood from two large cigar boxes (250 size),

some strip brass about $\frac{3}{32}$ " thick and $\frac{1}{4}$ " wide, a piece of $\frac{1}{8}$ " round brass wire 4" long and three pieces of $\frac{1}{16}$ " steel wire $2\frac{1}{2}$ " long; also brass screws and small wire nails. Side and end views of the frame are shown in Fig. 1. Two sides are cut to the shape and dimensions shown, with openings where the slide is opposite the condensers. The opening in the side nearest the objective is $\frac{1}{8}$ " larger on the vertical dimension than the side nearest the condenser, $\frac{1}{16}$ " more at both top and bottom being cut out to allow for the arms *a* of the transferring device shown in Fig. 4. The right inner edge of the opening on the side near-

est the objective is also thinned with a gouge or file to allow for the rod *p*, Fig. 4.

The top piece of the frame is a strip of wood 9" long, $\frac{5}{8}$ " wide and $\frac{1}{4}$ ", or a little over, thick. To the inner right end of this is riveted an L shaped piece of brass *b* $3\frac{3}{4}$ " long, made by bending a piece of thin strip brass $\frac{5}{8}$ " wide. This is

between the outer edges of these two bottom pieces, the one on the objective side extending the whole length of the frame, and the one on the condensers side only $3\frac{1}{2}$ " from the right end. This last piece is not put in until the final putting together.

The carrier, as shown in Fig. 2, is next to be

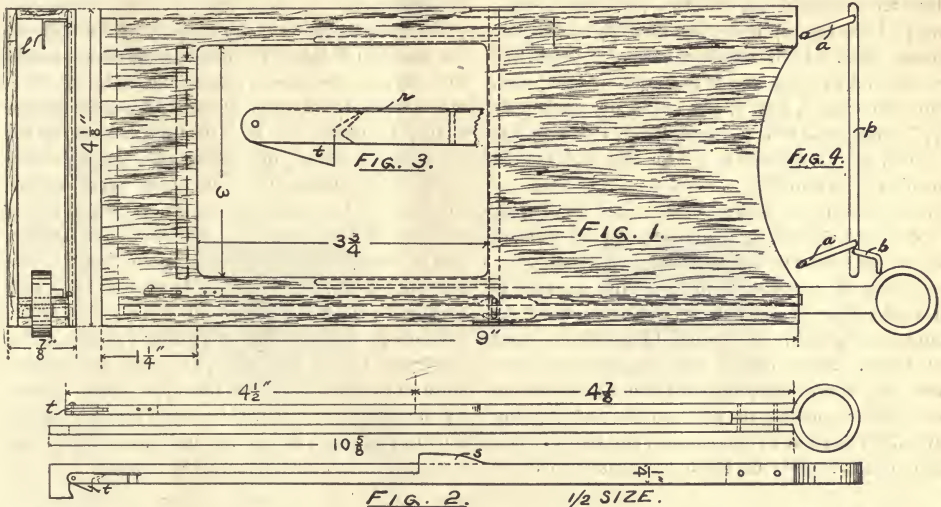

shown at the top of the end view, Fig. 1. A piece of 2-point brass printers rule, can be used, and can be obtained at any printer's office. At the same time get a piece of 8-point brass rule 12" long, from which to make the carrier to be described later. Two small pieces of brass $\frac{1}{8}$ " thick are also needed for bearings for the rod *p*, Fig. 4, and are $\frac{7}{8}$ " long, $\frac{1}{2}$ " wide. Holes centering $\frac{1}{8}$ " from the end, and $\frac{1}{8}$ " diameter are drilled in these pieces, also holes in each corner for small brass nails, and when the frame is put together they are nailed to the top and bottom pieces in slots cut to receive them, so that the centre of the large hole will be exactly $3\frac{1}{8}$ " from the right end.

Two strips of wood of same dimensions as the top piece are required for the bottom, which is double, the inner one being set $\frac{1}{8}$ " away from the other to allow the lower arm of the carrier to slide easily between them. Holes are bored $3\frac{1}{8}$ " from the right end and near the front edge for rod *p*, and a space cut out as shown in Fig. 1, around these holes to allow space for the arm *b*, Fig. 4. Two strips of wood $\frac{1}{8}$ " x $\frac{3}{8}$ " are glued

made; three pieces of brass $\frac{1}{4}$ " wide, $\frac{1}{8}$ " thick, one $9\frac{3}{8}$ " long, another $9\frac{3}{8}$ " long, and one $4\frac{3}{8}$ " long are needed. The short piece is bent to a $\frac{7}{8}$ " circle with two arms $\frac{3}{4}$ " long, to form the pull. If hard brass is used, it must be annealed by putting in a fire, heating to a red heat and slowly cooled. The upper arm made from the piece $9\frac{3}{8}$ " long, has the left end cut down to a width of a little over $\frac{1}{8}$ " wide for a length of $4\frac{1}{2}$ " on the inner end. A boss, s $\frac{1}{8}$ " wide and $\frac{3}{4}$ " long is brazed on to the front edge as shown in the top view, Fig. 2. A slot is then cut with a hack saw in the end as shown in the side view, Fig. 2 for the tongue *t*, and enlarged view of which is shown in Fig. 3. This slot is cut $\frac{5}{8}$ " deep from both sides to leave a V shaped projection.

A spring *r* about 1" long, and $\frac{1}{8}$ " wide made of thin spring steel, to be obtained of any jeweller, is then riveted in a recess filed in the front edge of the arm so that the end will press on the edge of the tongue *t*, causing it to project as shown in Fig. 3. The tongue is filed up from a piece of thin brass, to the shape shown in Fig. 3, holes

drilled and a riveted bearing made at the outer end.

The lower arm has at the end a hook shaped projection which is brazed on, as shown in the top view, Fig. 2. When the arms are completed they and the pull are brazed and riveted together. The transferring device, shown in Fig. 4, is next to be made. In a piece of round brass rod $\frac{1}{8}$ " diameter and $4\frac{1}{8}$ " long, drill two $\frac{1}{16}$ " holes in line, one $\frac{1}{2}$ " from the top end, the other $\frac{3}{8}$ " from the bottom side. Drill another hole $\frac{5}{8}$ " from the bottom end at right angles to the other two holes. The two arms *a*, Fig. 4, are made of steel wire $2\frac{5}{16}$ " long, and full $\frac{1}{8}$ " diameter. The arm *b* is $\frac{3}{4}$ " long, with a little over $\frac{1}{8}$ " on the end turned down as shown in Fig. 4.

After making an end piece of wood $3\frac{1}{8}$ " long, $\frac{5}{8}$ " wide and $\frac{1}{8}$ " thick, the frame can be put together. It can be nailed with small brass nails, but wood screws are preferable, allowing repairs to be made more easily, but the heads must be countersunk, and holes drilled to avoid splitting the wood. First fasten the top end and side pieces together, following with the inner bottom piece, after putting in position the transferring device. Then put in the carrier, the two wooden strip on either side of the lower arm of carrier

and then the outer bottom piece. Put in only a few screws at first and try the carrier to see that it does not bind anywhere. A piece of wood $\frac{1}{2}$ " long to serve as a stop, is then put between the two sides $\frac{1}{8}$ " to the left of the opening. One or two coats of shellac varnish will give a good finish to the wood and the brass can be laquered if desired.

To operate, pull out the carrier, put a slide in the space in front of the upper arm, then push on the carrier; the boss, *s* pushes the slide in till it meets the wooden stop. Then pull out the carrier again; at nearly the end of this movement the catch at the end of the under arm engages with the arm *b*, causing the arms *a*, to press against the front of the slide, moving it to the space at the back of the opening. Another slide is then put in, moved forward as before, in front of the one now there; the tongue *t* is pressed back as it passes the slide first put in until beyond it, when it again projects, and upon pulling out the carrier brings out the first slide, allowing the second slide to be transferred to the space just vacated by the first slide. It will be noted that each slide, during exposure, is in the one space for which the lantern has been accurately focused.

PATTERN MAKING FOR AMATEURS.

F. W. PUTNAM.

III. Green Sand Cores—Two Simple Patterns.

It often becomes necessary for the pattern maker to make a pattern for a casting that is to be hollow, or to have a hole through it, in which case it is customary to make the pattern of such form that it will leave a body of sand in the mold about which the metal will flow. The body of sand left in the mold forms the desired hole or opening, as shown at *a*, Fig. 9. This body of sand projecting up into the mold to form the opening in the casting is called a *core*, and may be left by the pattern itself, as in Fig. 9, or it may be made in a separate device, called a *core box*, and placed in the mold after the pattern has been drawn out. Cores made by the pattern alone are called *green sand core*.

Fig. 9 represents a mold made by a pattern of the shape shown in Fig. 10, which shows the casting of shoe. The pattern for this shoe will be the same shape as the casting, the necessary allowance being made in the size of the pattern to cover the shrinkage and finish of the casting.

SHOE.

For this pattern use a piece of clean dry pine. Plane the block to the required width and thickness and square the ends to the desired length. The first side planed up should be carefully tested with a try square; when found to be perfectly straight and true, it should be marked with two short parallel lines. This side is called the *face side*, and we will generally, in this pattern work,

consider the top surface of the pattern, as it is drawn from the mold, to be the face side. The next side is planed up it at right angles to the face side and is called the *joint side*. This side is tested with the try square, and when found to be straight and exactly at right angles to the face side is marked with one short mark. The block is gauged for thickness from the face side, and the third side is then planed down to the gauge line and is tested from the joint side.

point on the scale originally coming directly in line with the spur. The marks which are to be made on the face and joint sides of the block are called *witness marks* and are shown in Fig. 10.

Having finished the block to the required size, mark out the rectangular hole which is to be cut through the block as indicated by the dotted lines in the right end view of Fig. 10. The lines should be marked on both the top and bottom faces of the block, making sure that both the top

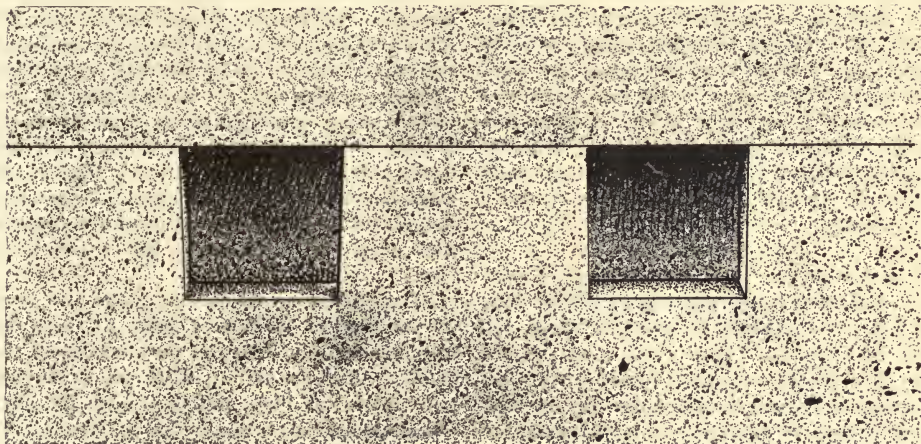

FIG. 9. MOLD MADE BY PATTERN.

The block is gauged for width from the joint side, and the fourth side is planed down to this gauge line, being tested from the third side. Gauging should always be done from the face and

rectangles are correctly located and of the right dimensions. Holding the block in a vise, next bore four holes with a $\frac{1}{8}$ " auger bit, one in each corner of the rectangle, the edge of the hole coming $\frac{1}{8}$ " inside the rectangle. In boring holes advance the bit until the spur just pierces the opposite surface, then remove the bit, turn the block round in vice and bore back. In this way there should be no splintered surfaces as a result of boring. A $\frac{5}{8}$ " auger bit should next be used, six holes being bored, one next each short side, and two next each long side, $\frac{1}{8}$ " being left in each case from the edge of the bit holes to the border lines of the rectangle.

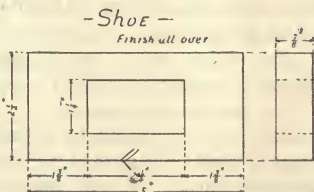

FIG. 10. PATTERN FOR SHOE.

joint sides of the block. In setting the gauge always measure the distance from the spur to the head with a rule, as the spur may easily have been bent and so make the scale which is cut on the bar of the gauge of no practical value, the zero

The hole is to be finished with a chisel, following the directions given in the last article. This hole should first be squared up from the face side, with no allowance for draft. Remembering that the face side is to be the top side of the pattern,

the allowance for draft is next made. The sides of the hole may be tapered with a flat wood rasp, in which case a file with one narrow edge "dead smooth" should be used. Such a file is generally known as a safety edge file. The safety edge is brought against the corners of the hole and prevents the file from digging in and so spoiling the shape of the hole. The sides of this hole should be carefully tested for draft, being very sure that there is no back draft. The draft allowance on the outside surfaces is finished last.

In clamping the pattern in the vise for chiseling, it will be found advisable to clamp a block against the pattern, thus preventing the wood from being broken away on the back surface of the pattern. A very little practice of this sort in the use of chisels, will be sufficient to warn the amateur that his chisels must be kept sharp, with a perfectly straight bevel not too blunt, and a straight edge.

OPEN END WRENCH.

The third pattern is a common form of open end wrench and is shown in Fig. 11. The block for this pattern should be about $9\frac{1}{2}$ " long, $2\frac{1}{2}$ " wide and $\frac{1}{4}$ " thick. The face side, joint side and third side should be planed up and tested. Set the gauge at $1\frac{1}{8}$ " and mark a centre line on both the wide surfaces, gauging from the joint side the whole length of the block. On this centre line

$7\frac{9}{16}$ " from the first cross line drawn. This second point *d*, Fig. 12, will be the centre for the half circle outlining the handle. Set the compasses at 1" radius and scribe a circle with *c*, Fig. 12, as centre. Mark this circle on both sides of the block. Next set the compasses at $\frac{1}{16}$ " radius and with *d* as centre, scribe a half circle on both sides of the other end. The remainder of the outline of the wrench is next to be drawn, following the dimensions given in the figure.

Having drawn the outline on both sides of the block, bore a hole with $\frac{3}{8}$ " auger bit as in Fig. 12. With a hack saw make cuts at *a*, Fig. 12, to meet the hole just bored. With a suitable chisel finish this opening down to the line, as there is now less chance of splitting this end of the block, beginning at *c*, Fig. 12 for the same reason. When this is done, make two saw cuts at *b*, Fig. 12, and rough down the block with a chisel. In finishing the curved fillet near *b*, begin with a medium sized gouge and finish with a half round wood file.

After completing the outline, gauge two lines on the edge of the handle, each $\frac{3}{32}$ " from the broad surfaces, to designate the thickness of the handle. With the parring chisel remove the portion outside the lines, cutting true to the lines and straightening across, leaving $\frac{1}{8}$ " next to the outline of the head, to afterward form a fillet where the head and handle join. This fillet may be formed with a very small gouge or a round "rat tail" file. Remembering that the face side is to be the top side of the pattern when removed from the mold, give the necessary draft to the pattern, not forgetting the opening at the head end of the wrench. Sandpaper the handle lengthwise, placing the sandpaper on a block for all flat surfaces. Round the corners very slightly with sandpaper and the pattern is ready for finishing.

FINISHING PATTERN.

All wooden patterns should be covered with some protective coating so as to prevent warping, due to the moist sand in the mold and to prevent glued joints from coming apart. This coating will give a smooth and glossy finish to the pattern, thus facilitating its withdrawal from the sand. Finished patterns, too, escape much of the rough usage commonly given them by moulders.

In practice there are two general classes of pattern varnishes. The first is composed of

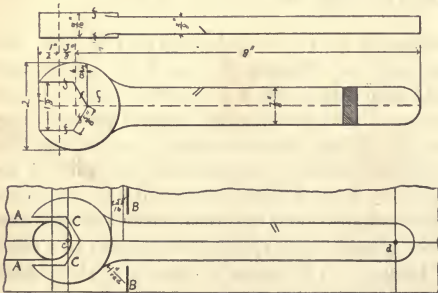

FIGS. 11 and 12. OPEN END WRENCH.

measure off a point $1\frac{1}{8}$ " from one end of the block. This point will be the centre *c*, Fig. 12, for the circle outlining the head. With the try square and knife mark a line through this point across the face side, next duplicating the line on the opposite side, squaring from the joint side. Measure off and make a line on the opposite end

Shellac, with or without some coloring indredient. The second comprises the better grades of *copal* varnishes. Copal varnish gives a better lustre than shellac but it is very slow in drying as well as more expensive, and so will not be thought of in connection with the finishing of our patterns. By changing the color of the shellac varnish, we may distinguish between core paints and the main body of the pattern, and also between patterns for different purposes, as, for instance, pattern for brass, iron, steel castings, etc.

Orange shellac varnish is made by dissolving orange shellac in alcohol. The orange shellac comes in thin flakes and may be dissolved either in wood (methyl) alcohol, or in grain (ethyl) alcohol. Wood alcohol is always *poisonous*, if taken into the system and shellac mixed with wood alcohol is very liable turn to a muddy color, therefore, I strongly recommend the use of grain alcohol. Black shellac varnish is made by add-

ing dry ivory black, or lamp black, to the orange shellac. We will use for our work black shellac for the main body of the patterns and the outside of the core boxes, and orange shellac for core prints and inside of core boxes.

First wipe the pattern clean and free from dust. The first coat of varnish should be fairly thick, applied smoothly, and allowed to soak thoroughly into the pattern. When this coat has become thoroughly dry, the pattern will feel rough, because the varnish has hardened any little projecting particles of the wood. This first coat should be rubbed smooth with a well worn piece of fine sandpaper, being careful not to cut through the varnish. Having wiped the pattern free from dust, apply a second coat of varnish, somewhat lighter than the first. This coat, when dry, is again rubbed down, and a third coat applied, three coats being usually enough to render the pattern impervious to moisture.

AN OIL IMMersed CONDENSER.

ARUHTR H. BELL.

The peculiar property of a condenser, of retaining charges of electricity is a valuable factor in spark coil operation. In the primary circuit of a coil, or more accurately speaking, across the make and break contacts of the primary circuit of a coil, we introduce a condenser which greatly increases the efficiency, by taking up the "extra" current induced in the primary. Often times these condensers are simple Leyden jars, and sometimes tin foil sheets insulated one from the other by waxed paper. In either case we have a conducting surface conferring, by induction, capacity upon another, and the more layers of foil and paper, or Leyden jars, as the case may be, the greater the capacity.

We find, in attempting to operate a make and break vibrator on an induction coil, where the condenser has been removed, that there is little or no spark at the secondary gap, and a very pronounced arc at the vibrator contacts. This arc tends to smut and eat away the platinum contact points, and we note that increasing the number of cells of battery causes a fatter arc at this point. We reason, therefore, that this spark

must be attributed to the extra current caused by magnetic influence of a soft wire core, and not to be any direct effect of the few cells used, for a separate test shows the cells to be incapable of rendering such a spark, without a core winding in the circuit. This spark value of a core enters into the construction of "wipe sparks" coils used in operating some gas engines.

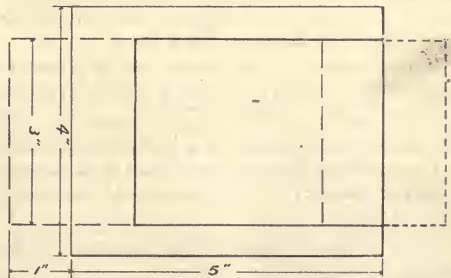

If we introduce across the spark gap, a condenser constructed of a very few layers of foil and wax paper, we note that the spark or arc at the contacts diminishes, and the secondary spark lengthens. From this we reason that more capac-

ity, that is, a larger condenser will cut down the spark to a point where the arc no longer damages the platinum, and a maximum spark results in the secondary. Likewise, in increasing the battery strength we find it necessary to increase the condenser capacity, to control the sparking.

A condenser for a primary discharge seldom punctures under primary influences, even if constructed of quite thin wax paper, but such a construction would preclude its use across the terminals of a secondary. For many of us have seen by experience, that a secondary discharge of less than half an inch will pass through many substances like waxed paper, fibre, rubber, mica, etc., which are practically perfect dielectrics with low potential, and any ordinary condenser of wax paper and foil would puncture through and through with the first discharge of such a secondary.

We find, however, that a series of Leyden jars of a specified capacity will change the character of the secondary spark. While the length is diminished, the spark becomes a fat flame, and its color is changed to a dazzling white. As different capacities of condensers are required for various lengths of discharge, the importance of arranging a set of condensers adjustable to ones requirements becomes patent. Leyden jars are bulky, and easy to accidental discharge by contact with exterior substances, so we must resort to an adaption of an old-time idea, known as "Franklin plates." Almost every amateur or a friend has disabled more or less in dry plate photography, and glasses of 4" x 5" dimensions are readily obtained. The gelatine film can be removed by an application of hot water.

Next procure at a hardware store, 50 pieces of very thin tin (tinned iron) which is cut into pieces 3" x 5" square. Procure some pieces of card board of same thickness or a trifle thicker than the tin. Cut 50 pieces 4" x 5", and then remove from each piece a 3" x 4" section as illustrated in the diagram.

With shellac securely attach a piece of the board to each glass, and the insert a strip of tin in the space provided for it. In assembling this condenser, take twenty glasses and tins, and stack the one on the other so that the projecting ends of 1, 3, 5, 7, etc., will protrude at one end, and 2, 4, 6, 8, etc. at the opposite end. These

glass plates should then be firmly tied in place with binding twine. Next do another twenty in the same fashion; also the remaining two fives. Solder a heavy wire, which we will designate as a "lead," to the edges of the strips protruding at at each end, and have these leads long enough to permit connecting one condenser to another when desired.

When we connect these sections in series, the combined capacity is equal to the sum of capacities of each condenser, and when two condensers are connected in parallel, the combined capacity is equal to the product of the individual capacities, divided by the sum of these capacities. Also with three condensers in parallel we figure the combined capacity of any two, by this formula, and using this resultant capacity, continue the calculation with another condenser. By using different combinations in series and parallel, we are able to vary our capacity to quite an extent.

Immersing these condensers in a liquid tight container of wood, or a jar, filled with insulating oil, like transil, paraffine or linseed oil, renders them more efficient under high potential conditions.

U. S. Consul-General Guenther, Frankfort, Germany, reports a newly invented "milk stone," or galalith, or petrified milk. It is manufactured from skim milk in the following manner:— By a chemical process the casein is precipitated as a yellowish brown powder, which is mixed with formaline. Thereby a hornlike product is formed called milk stone. This substance, with various admixtures, forms a substance for horn, turtle-shell, ivory, celluloid, marble, amber, and hard rubber. Handles for knives and forks, paper cutters, crayons, pipes, cigar holders, seals, marble, stone ornaments, and billiard balls are now made of skimmed milk. The insolubility of galalith, its easy working, elasticity, and proof against fire, make it very desirable. Already 20,000 quarts of skimmed milk are daily used for this purpose in Austria.

The Amateur turning lathe is a practical, well made tool. Those who have already received them are more than pleased with its construction.

A MERCURY INTERRUPTER.

GEORGE J. ATKINS.

Mercury interrupters have long been popular with users of high potential coils, but their cost, as compared with the simpler spring hammer vibrators, precluded their general adoption by amateurs.

Following is given a description of an efficient mercury-dip interrupter which was constructed from a cheap 2½" door bell. The bell was stripped of gong and cover, and the ball hammer that taps the gong, and then mounted edgewise on a piece of wood 3½" x 2½" attached by screws to the base board which is about 5" x 7". The rod carrying the hammer was left on the armature, in the fact the rod had to be lengthened by soldering on a short piece of brass wire.

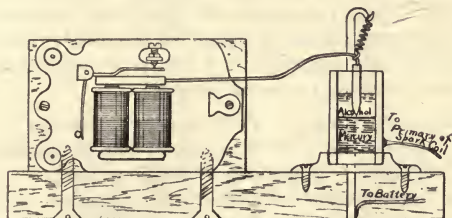

The dash pot which contains the mercury, is a piece of iron gas pipe about 1½" long, and ⅝" diameter, and also fastened to the base board by fitting an iron cap to the lower end, or the bottom end may be plugged with a piece of wood. On the end of the brass wire soldered to the hammer rod, is fitted a cigar-shaped piece of brass rod of about ⅛" diameter. This shape was adopted to permit easy ingress and egress in the mercury. A half inch of alcohol is kept in the pot on top of the mercury when in use. One side of the primary battery, used to energize the primary of the coil, is connected to the iron dash pot, and the other side of the battery to the primary of the coil. The return end of the primary coil, is connected by means of a very flexible wire spring to the hammer rod of the bell, the spring being held by a brass rod, the lower end of which is driven into the base board and the upper end formed with a

hook. A spring can be made by winding fine brass wire around a wire nail. A separate cell or two of battery is used to operate the bell armature, and adjustment is made by bending the hammer rod or "make-and-break" rod, so that the brass contact will be just outside of the mercury, but still covered with alcohol when the bell magnets are not energized.

When the bell armature operates, the contact piece enters well into the mercury, thus completing a circuit for the coil battery.

U. S. Minister H. N. Allen, of Seoul, Korea, has issued the following circular letter as a reply to the many inquiries from the United States at that legation relative to ginseng seeds and plants, and how to secure the same, etc. It is becoming impracticable for his office to give attention to the numerous requests for information regarding ginseng received by every mail or to furnish supplies of ginseng seeds and plants.

Information may be had on the subject from the publications of the United States Department of Agriculture and from the numerous firms engaged in supplying ginseng seeds and roots in America. With great difficulty living roots have been shipped to America and a reliable supply must now be available. At least one enterprising American (of San Francisco) has spent some months at the ginseng farms in Korea, studying the culture and conditions and taking away with him a large shipment of living plants, so that dealers in the United States must now have a plentiful supply of reliable plants and fresh seeds.

Ginseng seeds are not supposed to germinate after having dried out. Even if there were seeds in Korea, therefore, it would be useless to secure ginseng seeds from them. The ginseng farms are some 60 miles distant from Seoul, and there is no person there to whom one may apply for seeds or plants. The American missionaries residing near the farms have wisely decided not to attempt to export the seeds and plants, as such a course would ultimately cause trouble for them with the natives. If all the ginseng plantations in America succeed the product will be of little value. The only market for the roots is in China and it is overstocked, while the Korean product which seems to be of especial value, due to conditions of soil and climate, is increasing so greatly that the purchasers of the last crop were obliged to destroy a large quantity in order to keep the supply within the demand

AMATEUR WORK

77 KILBY ST., BOSTON

DRAPER PUBLISHING CO., PUBLISHERS.

A Monthly Magazine of the Useful Arts and Sciences. Published on the first of each month for the benefit and instruction of the amateur worker.

Subscription Rates for the United States, Canada and Mexico \$1.00 per year. Single copies of any number in current volume, 10 cents.

TO ADVERTISERS.

New advertisements, or changes, intended for a particular issue, should reach the office on or before the 15th of the previous month.

Entered at the Post-office, Boston, as second-class mail matter
Jan. 14, 1902.

MAY, 1904.

To make this magazine of the greatest possible value and interest to its readers, is the earnest desire of the publishers. In the selection of subjects to be presented in the successive issues the wants of readers are followed in every possible way in which these wants have been indicated. We think, however, there are many readers who have in mind some particular subject in which they are especially interested, and we earnestly request every reader to write a short letter advising us upon the following points.

1. What general subject is most of interest to you; that is, electricity, mechanics, wood working, boat building, photography, etc.

2. What additions or changes can you suggest, which would make the magazine of greater value and interest.

A general response to this request will enable us to carry out more satisfactorily certain plans now in preparation, and we earnestly request that each and every reader will favor us at an early date with their suggestions.

We have received numerous inquiries calling for special reply by mail, yet without the neces-

sary enclosure of stamp for return postage. These are now so numerous that we are obliged to decline to reply by mail to inquiries not accompanied with postage. We must also announce that replies to inquiries upon technical subjects are subject to delay; as considerable investigation is sometimes necessary before a reply can be sent.

BOOKS RECEIVED.

BENT IRON WORK, BASKET WORK, TAXIDERMISTRY.

Handicraft series, edited by Paul N. Hasluc, 160 pp. 4 × 7 inches, 50 cents each. Cassell & Co., Ltd. London and New York.

The Handicraft series of manuals, in which the above mentioned three books are included, present the several subjects upon which they treat in a plainly written and well illustrated manner. Nineteen different manuals are included in the series, a list of which may be obtained by application to the publishers. Many of them are upon subjects which are of undoubted interest to readers of this magazine, and are recommended as being of much value and interest.

WHO DISCOVERED PHOTOGRAPHY. George E. Brown and C. W. Canfield, Photo-Miniature, 25 cents. Tennant & Ward, New York.

All photographers will find this number of much interest. The historic development of photography is traced from the beginning to the present day, and many parts have all the interest of romance, while being but the presentation of facts of the past. It could well be taken up as supplementary reading in manual training schools.

The Technical World is the name given to a new monthly magazine published by the American School of Correspondence, Chicago, Ill. As its name implies, it is of a technical character, but not to such an extent as to be without interest to the general reader. The various subjects presented in the first number include:—"Radium, The Milling Machine, Wireless Telegraphy, Exhaust Steam Heating," and miscellaneous subjects in similar lines. The large number of eminent writers available to the publishers will enable them to make the magazine of undoubted interest to those desirous of following the progress of scientific and industrial affairs.

A CHAMBER SET

JOHN F. ADAMS.

I. The Bedstead.

The chamber set to be described in this and following numbers of this magazine is of colonial design, with a strong, substantial appearance, and yet not carried too far in the way of heaviness. It is such a set as any woodworker will find pleasure in the making, and pride in its possession when completed. It can be made in either mahogany or oak, though more especially adapted to oak; the strong marking of the latter wood when brought out with a dark finish producing an exceptionally fine appearance.

The three latter pieces may have to be glued up, but this should be avoided if possible to secure well marked stock of the full width. It will also be necessary to make sure that all the pieces are thoroughly dried, as shrinkage in the completed work will be quite objectionable.

To begin with the head-board; the corner posts are 4' 6" high. The upper cross piece, 7" wide, is 1" over than the top of the posts, mortises 1" deep being made for same the full size of the cross piece. Another mortise for the centre cross

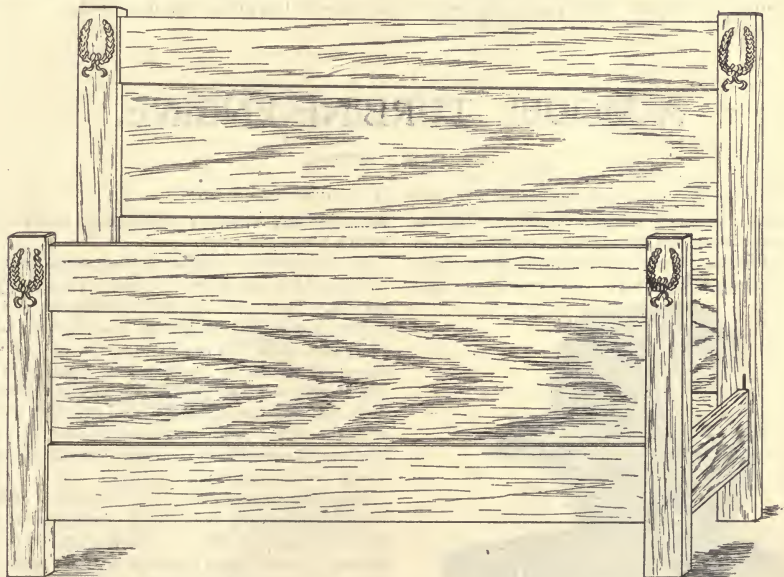

The material required is as follows:

- 2 pieces 4' 6" x 4" x 1 $\frac{3}{4}$ "
- 2 pieces 3' x 4" x 1 $\frac{3}{4}$ "
- 2 pieces 4' x 7" x $\frac{5}{8}$ "
- 2 pieces 4' x 8" x $\frac{5}{8}$ "
- 1 piece 4' x 6" x $\frac{1}{2}$ "
- 2 pieces 6' x 8" x $\frac{3}{8}$ "
- 2 pieces 3' 11" x 14 $\frac{1}{2}$ " x $\frac{1}{4}$ "
- 1 piece 3' 11" x 12 $\frac{1}{2}$ " x $\frac{1}{4}$ "

piece, 6" wide, is made 14" below the upper one. The mortises for the lower cross piece, 8" wide, is 12" below the centre one, the lower edge being 6" from the floor. These mortises are all centered on the posts.

The upper panel is 14" wide in the clear; the lower one 12" wide. Grooves $\frac{5}{16}$ " deep are cut in the cross pieces and posts to receive the edges

of the panel pieces; and so located as to have the panels set in $\frac{3}{8}$ " from the front of the cross pieces. Accurate measurements must be made and lines laid off with a marking gauge. A $\frac{1}{4}$ " grooving plane will be necessary to cut the grooves in nice shape. On the front of the post a slot is cut for the side board hangers which centres 1" from the outer edge of the post. The hangers should be purchased in advance from which to ascertain the correct width of the slot, which should be located to bring the side board 6" from the floor, before castors are added. When all fittings are completed, the head board is set up with glued joints and further strengthened by two $\frac{1}{4}$ " dowel pins put through from the back so not to show at the front.

The foot board is made in the same way, the posts being 3' high; the upper cross piece 7" wide, the lower one 8" wide and the panel 14" wide in the clear. The top edge of the upper cross piece is 1" below top of the posts. The cross pieces are

also pinned with dowel pins put through from the back, and carefully cut off to show as little as possible. Slots for the side boards are cut on the inside at same height as on the head board.

The side boards are 6' long and 8" wide. The method of providing for the slats can be seen by inspecting any wooden bed, so will not be described. After setting up both head and foot-board, the tops and bottoms of the posts on both are beveled off slightly as shown. The ornamental carved work shown at the tops of the posts can be purchased of furniture manufacturers supply houses located in most of the large cities, but can be omitted if not obtainable. If same are purchased, two others of slightly smaller size should be got at the same time for the bureau, if same is to be made, and which will be described in the next number. The finish may be a dark green or brown or black, if of oak, and dark mahogany if the latter wood is used.

A MODEL TURBINE ENGINE.

ARTHUR J. WEED.

Copyright April, 1904 by Arthur J. Weed. All rights reserved.

In designing and constructing a model turbine engine we are confronted with several problems which do not have to be taken into consideration when dealing with a reciprocating engine. The most important

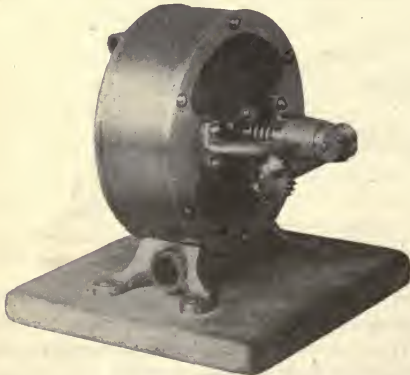

of these are:—The high speed; the balancing of motive parts, adequate bearings and a positive oil supply. In the design here given, these details have been carefully worked out, yet the construction is such that it will not be found difficult of accomplish-

ment by any amateur possessing a small lathe fitted with a plain slide rest.

In the turbine engine the principle that "Action and reaction are equal" is most practically demonstrated. The most efficient turbine engine is the one having a comparatively large number of buckets, but to secure this in a model the size of the one here shown, it would be necessary to turn out the motor wheel with a solid rim, like the flywheel of an engine, and mill out the buckets from the solid metal using an end milling cutter for the purpose. This construction would necessitate the use of special facilities with which few amateurs are equipped.

Before beginning a detailed description of the parts, we will first study the general arrangement of the assembled model. Fig. 1 and 2 show the complete model. From these views it will be seen that the steam inlet is cast as a boss on the side of the casing instead of being a separate piece, for which a hole would need to be drilled diagonally through the casing. The exhaust steam passes out at the bottom of the casing, which facilitates the keeping of the interior free from water. The reduction of speed is accomplished by a worm wheel mounted on the turbine shaft and engaging with a gear on the driving shaft. This permits of a reduction of twenty to one, yet allows an increase of speed, if so desired, by substitut-

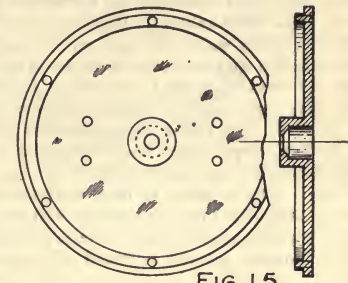
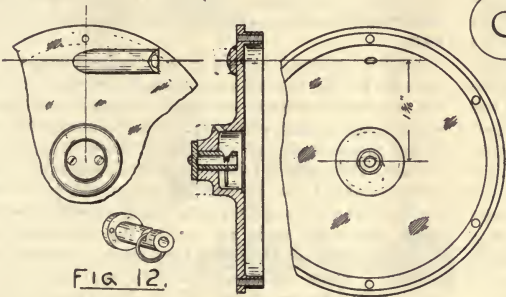
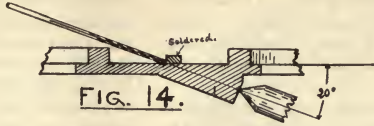
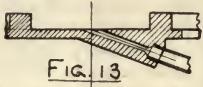

FIG. 12.

FIG. 10.

FIG. 15.

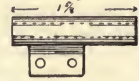
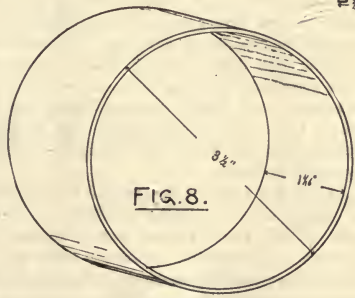

FIG. 18

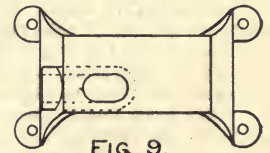

FIG. 9.

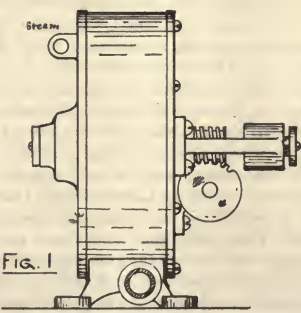

FIG. 1

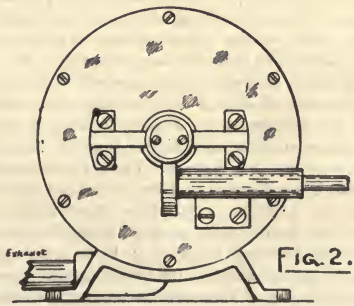

FIG. 2.

ing a smaller gear on the driving shaft. The side thrust of the jet of steam on the turbine wheel is offset by the thrust of the worm wheel on the gear of the driving shaft.

The shaft of the turbine wheel is made as long as possible, and the outer end supported in an outboard bearing. Each bearing is fitted with an oil ring and reservoir. Where the shaft passes through the casing

a stuffing box and gland is introduced. As the pressure at this point is only that of the exhaust steam a piece of felt or candle wicking will be sufficient packing to use. We will first consider the construction of the turbine wheel.

This piece of the model requires to be very carefully constructed, and when completed the wheel should be in perfect balance. The design requires forty vanes or buckets arranged around the circumference of the wheel. Figs. 3 and 4 show in detail the construction of the wheel. This wheel is made with a solid web between the hub and rim, instead of being spoked; the reason for this being that the entire surface of the wheel may be turned up true to make it run in perfect balance. The shape of the buckets is shown in Fig. 7. The shape of the lower portion of the bucket is spherical with a projection which fits into a slot of the wheel. The forming of these buckets will be the greatest difficulty that the amateur will encounter in the construction of the model. These, however can be procured formed up and trimmed ready to set in the wheel.

To form up the buckets take two pieces of steel $\frac{3}{8}$ " x $1\frac{1}{2}$ " and about 2" in length. Clamp the two pieces together and drill two $\frac{1}{8}$ " holes for guide pins near one end, as shown in *A*, Fig. 19. The opposite ends must be squared up and a center punch mark made on one of the pieces $5-64$ " from the edge where the two pieces join. Drill a small hole to a depth of $\frac{3}{8}$ ", using a drill about No. 24 size. With the two pieces firmly clamped together drill into the same hole with a $\frac{1}{8}$ " drill to the same depth and follow this up with a ball end cutting mill as shown in *B*, Fig. 19. This can be made from a piece of $\frac{1}{2}$ " steel and the end rounded to a spherical form. The teeth can be filed in and the tool then hardened and tempered. When using this tool it will be necessary to remove it from the work often and clear the teeth of the particles of material cut away from the work. If this is not done the grooves will fill up and the cutter refuse to work. When the depression is cut to the proper depth a piece of $\frac{1}{2}$ " steel is turned to the same form as the end of the cutter and inserted in one of the pieces of steel as shown in *D* Fig. 19. This can be fastened in position by a rivet. This forms a punch and die for forming up the buckets. The material of which the buckets are made should be soft brass about No. 26 gauge. This should be cut into pieces considerably larger than the size of the buckets, say one inch square. Place the forming tools with the "die" below and lay one of the pieces of soft brass in position on it. Place the "punch" above it on the guide pins, and holding the three pieces together, transfer them to a large vise and squeeze them together firmly. On relieving the pressure the sheet of brass will be found in the form shown in *E*, Fig. 19, and only requires to have the flat part trimmed away to make it into a bucket of the proper shape for this model.

After the required number have been formed up, one of them should be very carefully laid out and cut

to the size and shape shown in Fig. 7, and this can be used as a gauge with which to mark out the others. Fig. 4, the cross section of the turbine wheel, shows the rim turned out to form the same shape as the bottom of the bucket. This can be somewhat modified as shown in Fig. 5, where the bucket rests on two projections, one on either side of the rim and the centre cut away on a straight line. The latter is the easier construction and keeps the buckets in position equally well.

After the wheel is turned to the required shape the slots for the buckets must be made in the rim. If one has a milling machine or a lathe arranged for plain milling, the work is very easy. Most amateurs will be under the necessity of marking off the divisions with dividers and cutting the slots with a hack saw. The divisions should be marked off very carefully and the saw held at right angles to the rim of the wheel when used. After the slots are cut in the wheel and the buckets formed and trimmed they must be soldered in position. Place the wheel flat on a level surface and set the buckets in place. If the slots have been cut with a hack saw the thickness of the metal of the bucket will not fill it up. In that case small pieces of sheet brass can be cut and set in at the front of the bucket. When the buckets are all in place wrap a piece of iron wire around the outer ends to hold them securely while being soldered. In soldering, a flame can be used direct on the wheel, or it can be done with a tinsmith's copper. Do not use a large quantity of solder. All that is required is to lock the buckets while their tops are being turned off to nearly the diameter of the inside of the flat brass ring which is to surround them.

Before the buckets are turned off, the wheel should be placed in a permanent position on the shaft. The ends of the shaft should not be turned down to the size of the bearings, however, until the wheel and buckets are entirely finished. The flat ring surrounding the buckets is made from a piece of three inch brass tubing about 1-16" in thickness. This should be placed on a block of wood which is held in the jaws of the lathe chuck, or fastened to the face plate, and trued up to a width of 7-16" inch.

In turning down the tops of the buckets use a sharp pointed tool and take very light cuts. Turn them down until the flat ring can be almost forced on, then lay the wheel down on a flat surface, heat the ring evenly all around and it will expand sufficiently to drop over the tops of the buckets. It this is carefully done no soldering of buckets to the ring will be necessary. The shaft and wheel are again mounted in the lathe and the wheel carefully turned all over, using a very pointed tool and taking very light cuts. This should put the wheel in perfect balance. Lastly, turn the ends of the shaft to the dimensions shown in Fig. 6. When the shaft and wheel are complete and supported lightly between centres, they should stand in any position in which they are placed. Should the wheel revolve it would indicate that one side of the

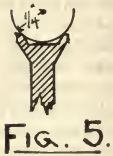

FIG. 5.



FIG. 4.

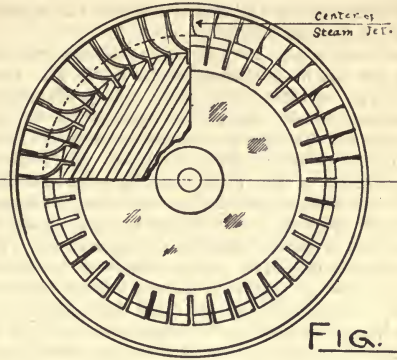

FIG. 3.

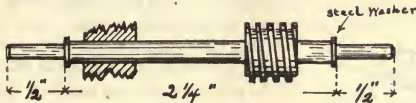

FIG. 6.

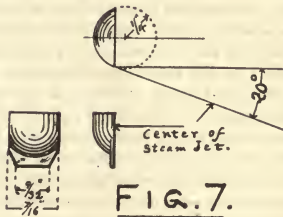

FIG. 7.

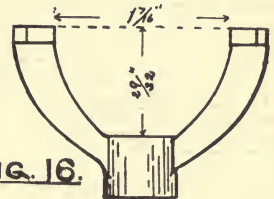
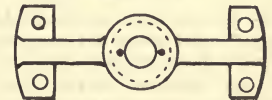

FIG. 16.



wheel is heavier than the opposite side. In this case, it will be necessary to balance it by adding a little to the lighter side or drilling a few small holes in the rim of the heavier side.

The casing of the turbine consists of a piece of $3\frac{1}{4}$ " brass tubing about 1-16" thick shown in Fig. 8. Into each end of this tubing a head is fitted. The tubing should be forced on a wood mandrel turned to tightly fit its inside diameter. Both ends should be trued up parallel, leaving the length of the tubing 11-16". To the lower side of this tube is attached a base, Fig. 9. The upper part of this base is turned out, or carefully filed, to fit the outer curve of the tubing. A boss is cast on one end of the base, and is drilled out to fit the exhaust pipe. Where the drill comes through, an elongated hole will be formed on the top curve of the base. A corresponding hole should be marked out and cut through the side of the tubing, and after the four holes in the feet are drilled the two pieces are soldered together.

The two heads for the casing cannot be made from the same pattern without a considerable waste of

material and extra work. For the head on the "steam" side of the turbine, Fig. 10, the pattern should be made with a straight hub for a chuck piece, as indicated by the dotted lines. This is for the purpose of holding the casting firmly in the chuck while it is turned to fit the tubing; the inside surface turned off; the oil reservoir finished; and the $\frac{1}{2}$ " hole for the bearing bored through. All these operations must be done at one setting; i. e. the castings must not be disturbed in the chuck until all these operations are finished. This is absolutely necessary in order that the parts shall all "line up" when the work is completed.

The $\frac{1}{2}$ " hole for the bearing should not be made by starting a $\frac{1}{2}$ " drill and cutting the hole while the work revolves, for the hole would, in all probability, run crooked. Start with a smaller drill, say 3-16", and when that has been put through, use a small boring tool in the slide rest of the lathe and true up the hole, taking repeated cuts until it is almost to the required size, then run a $\frac{1}{2}$ " reamer through to finish it. The outside diameter of the head should be left a

trifle larger than the $3\frac{1}{4}''$ as it will add to the appearance of the finished model.

When cutting out the oil reservoirs turn out the groove for the brass washer shown in Fig. 11. This washer is to be soldered in place, but this must not be done until the oil ring for the bearing, Fig. 12, has been placed in the aperture and the screw holes of the heads drilled as will be explained later. After finishing the inside of the head it can be reversed in the chuck and held by the inside surface of the flange while the extra part of the chuck piece, shown in dotted lines, is cut away and the end squared up. Two holes are to be drilled into the oil reservoir, one above for the purpose of supplying oil, and the one below to be used to drain the reservoir. They should be drilled with a No. 42 twist drill and tapped with a No. 4-36 tap. Machine screws can be used to stop these holes when the model is in operation.

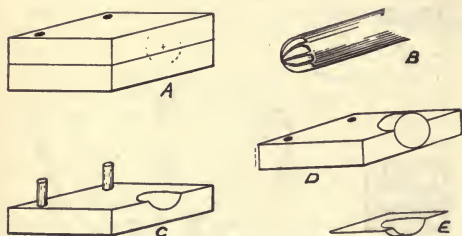

Fig. 10.

The bearing sleeve is clearly shown in Fig. 12, and a cross section of same is seen in Fig. 10. For this purpose a piece of brass rod can be used. Two pieces are to be made, one for each bearing. In addition to the length required for the bearing, the pieces should be cut out of sufficient length to hold in the chuck. When the extra length is gripped in the chuck jaws, centre the end of the revolving piece with a sharp pointed tool and start a smaller drill than the size of hole required; after which the hole is trueed up with a very small boring tool held in the slide rest and finished with a reamer. Next turn down the outside to $\frac{1}{2}''$ and square up the shoulder of the outer end. The bearing is held in place by the two small adjusting screws as shown in Figs. 10 and 12. The groove for the oil ring can be cut with a file or hack saw, and the reamer must be again inserted to remove the burr. The oil ring can be made from a piece of tubing.

The next important operation on this head is to drill and ream the steam nozzle in the lug cast on the outer surface. The line of the centre of this nozzle should be at an angle of 20° with the inner surface of the head, as shown in Figs. 13 and 14. Fig. 13 is a horizontal section cut through the centre of the lug. This shows the manner in which the hole is drilled. The position of the hole is laid out on the inside of the head as shown in Fig. 10. It should be on a direct

vertical line with, and $1\frac{5}{16}''$ above the centre of the head. Mark the point with a centre punch. When this has been done a small piece of metal, shown in Fig. 14, should be soldered on just outside. This is to prevent the drill from running off to one side when it is started. A centre punch mark should be made on the outer end of the lug at the proper point to bring the finished hole at the proper angle with the turbine wheel. Against this centre punch mark, the point of the back centre of the lathe is placed and the hole drilled. When drilling the hole the head must be carefully held up or its weight will break the drill. Use a No. 60 twist drill. The hole is next reamed out carefully with a taper reamer from the inside of the head. The hole should be $1\text{-}16''$ in diameter at that portion where it emerges into the casing. The outer end can be counterbored from the outside to fit the steam pipe, and the entrance to the nozzle from the pipe beveled off as shown.

The other head requires less work. All the turning can be done at one setting of the casting in the chuck. The projection of the stuffing box on the inside of the head is to be used as a chuck piece. This is firmly grasped in the jaws of the chuck. The outer diameter of the head is first turned down to the same size as the opposite head. The inside flange is next turned down to the same diameter as the inside of the $3\frac{1}{4}''$ tubing. This can be done by using a bent tool in the tool post of the slide rest. It can be gauged for size by using a pair of calipers and setting them to fit the finishing diameter of the flange of the other head. The gauging of the piece of work by the caliper must be done while it stands at rest, for if done when the work is revolving the tendency will be to leave the flange too large, as the calipers pass over a revolving piece of work with greater ease than if stationary.

The outside surface of the head is next turned off true and the recess for the gland bored out to the proper size. The small hole for the shaft should next be put through and this should be done very carefully, as this will aid materially in the final lining up of the parts when the model is assembled, as will be described later. The hole should be first drilled with a smaller drill than the finished size called for, after which a small boring tool is used to true up the hole and fit it to the exact diameter of the shaft of the turbine wheel. The reason for doing this is that when the outboard bearing of the shaft is completed and ready for attaching to the casing, the wheel and shaft can be inserted, and this hole in the stuffing box will hold the shaft in alignment until the bearing can be set into place and the position of the holes for the screws marked on the head. When the outboard bearing has been fitted, the hole in the stuffing box should be enlarged a little so that the shaft will not touch it.

The packing gland is shown in Fig. 17 and will not require an extended explanation. It should be a sliding fit in the stuffing box and the hole should be at least $1\text{-}32''$ larger than the diameter of the shaft. Two clearance holes for No. 2-56 screws should be drilled in

the flange and tapping holes to correspond marked off and drilled in the head. No finishing is required on the inside of this head.

The two heads can now be marked off and drilled for the screws which are to hold the casing together. Lay off six points around the edge of the flange of the head first described, Fig. 10, and mark them with a center punch. Drill these holes through, using a No. 42 twist drill. When all six holes are drilled place the flanges of the two heads together and hold them in position with a clamp. The projection of the stuffing box on one head will enter the oil reservoirs turned in the other head. With the heads securely held together use one of the holes as a guide for the drill and start a hole in the other head. This must not go deeper than the bevel of the lip of the drill. Mark the other five holes in the head in the same manner, after which the two heads can be separated. The holes marked should be drilled through with a No. 33 twist drill, this being a clearance hole for a No. 4 screw. The holes drilled with the No. 42 drill are next tapped with a No. 4-36 tap.

After these holes are drilled the washer shown in Fig. 11 can be soldered in to place to form the oil reservoir in the head Fig. 10. The casings can then be assembled with the wheel and shaft in place.

The outboard bearing should be held in the jaws of the chuck by the outer end of the hub so that the feet project toward the slide rest. Rotate the lathe head by hand and measure with a tool in the rest to see that the piece is chucked so that the feet project equally. With a centering tool in the slide rest mark a center in the revolving hub of the casting, and using the same size drill as used for the hole in Fig. 10 put a hole entirely through to size it for one of the bearings shown in Fig. 12. The details of the parts are shown in Fig. 16.

The oil reservoir is next bored out and the little depression made for the washer. The washer, like the corresponding one in the other bearing, must not be soldered into place until the oil ring has been placed inside. The bottom of the feet must be faced off while the casting is in the chuck, lights cuts with a pointed tool being made so not to loosen work. The piece can then be removed from the chuck and the bearing sleeve fitted. The holes for two adjusting screws are next drilled and tapped, after which the clearance holes for the screws are placed in the feet. The bearing can now be slipped onto the end of the shaft projecting from the assembled casing and the position of the screw holes transferred to the casing.

The head, Fig. 15, must now be removed and the holes drilled and tapped. The hole in the back of the stuffing box can be enlarged, as mentioned, and the head replaced. The worm wheel should next be placed on the shaft in the position shown in Fig. 6 and secured by a very small set screw drilled and tapped into one end of the worm.

The bearing for the driving shaft, Fig. 18, is best finished by centering at both ends and drilling the

the hole when the casting is held against the back center of the lathe. The drill used should be a trifle smaller than 1-4". Be careful that the drill does not touch the end of the back center. When the hole is nearly through, a piece of hard wood or metal should be interposed to prevent injury to the drill or center. The hole can then be reamed with a 1-4" reamer, after which it can be placed on a 1-4" mandrel and the ends squared up. If desired, the outside of the bearing can be turned down and finished on either end. If finish is desired over that portion where the flange is attached it will be necessary to do this with a file as it cannot be turned. The back of the flange should be filed up flat and parallel to the hole for the shaft, after which two screw holes are drilled.

The gear wheel and shaft are fastened together by a pin or screw and placed in position in the bearing. These parts are then held in place on the casing until the position of the screw holes are located. The points of the teeth of the gear should not be allowed to "bottom" on the worm, yet they should have sufficient contact.

If desired, a small sheet metal oil pan can be formed to fit under the gear wheel for lubrication and a cover could be made to enclose all the gearing, but there are so many who prefer to "see the wheels go 'round'" that these parts have not been shown. No driving wheel is shown on the end of the driving shaft. This must be made of the proper size to give the required speed to whatever model or piece of apparatus it is required to drive.

When the final adjustment of the parts is made the turbine wheel should run just as close as possible to the head containing the nozzle, but without touching it. Perhaps the easier way to make this adjustment is to loosen the screws in the bearing sleeve of the "Steam" side and screw up the adjusting screws in the outboard bearing until the turbine wheel rubs against the side of the casing when the shaft is revolved by hand. Then turn these screws back a half revolution and carefully tighten up the screws on the "steam" side until the bearing sleeve comes against the shoulder of the shaft. Be careful that the sleeves are not forced up too tight, as it is preferable to have a little play endwise on the shaft though this should not exceed 1-32". A stop cock should be placed on the steam pipe as near the model as convenient.

The uses of seaweed are numerous; it furnishes thousands of tons of fertilizer, many nutritious foods, and a variety of chemicals, especially iodine and bromide. Other uses are in sizing fabrics, as a mordant in dyeing, in refining beer, in making paper, fishing lines, ropes, as an upholstery stuffing, as a packing for china, etc. The Japanese have discovered many uses for this material, of which there are countless varieties.

The Amateur lathe is well worth having.

AN 80-WATT DYNAMO.

W. C. HOUGHTON.

The machine to be described in this article is intended to be of the simplest possible construction consistent with good workmanship and fair efficiency. It is of the bipolar type with a single field coil, and laminated armature. It might be easier to build it with a solid cast iron armature, but its output would be much smaller, while the power required to run it would be greater. Dynamos of such small size are at best rather inefficient because the field magnet must be made very strong or they will not generate.

This machine may be used either as a generator or as a motor. If used for the latter purpose, it will run a small lathe, several sewing machines or any similar machinery. The winding described will be what is known as *shunt* winding, i. e., the field will be connected in multiple with the armature. The effect of this is to make the machine run at practically constant speed as a motor, or to give a constant voltage as a dynamo. Series wound generators are used only for arc lights or for special purposes. They will not charge storage batteries nor run incandescent lights or motors satisfactorily. Series motors are only used where the speed must be varied between wide limits.

First, a few general remarks about methods of construction, and the order in which the various parts of the work should be taken up. All machine work should be completed first. Then the insulation of field and armature should be done, and lastly the winding. To do the machine work a good lathe is a necessity. An engine lathe is best, but a hand lathe with a good slide rest will do, if it will swing at least 9". A planer or shaper and a milling machine can also be used if available, but are not absolutely necessary. The field magnet casting should be taken up first. Plane or file off the feet on the base till it will stand perfectly true and firm. Drill a $\frac{1}{2}$ " hole in each foot, placing it well out toward the end so that screws may be put in easily. Next mark and centre punch the bosses on each side exactly in line with the centre of the cylindrical portion of the field, that is, the magnet core. Centre drill one of the bosses and drill a hole $\frac{3}{4}$ " deep in the other and tap a $\frac{3}{8}$ " No. 16 thread. These are for use in winding the field, which is done in the lathe.

The field may now be bored. This is best done by bolting to tool carriage of lathe, and using a boring bar with fly cutter. The ends of pole pieces may be faced off at the same operation by setting the cutter out and grinding it so it will cut on sides. If the tool carriage is not so built that the casting can be mounted on it, the next best way is to mount it on an angle-plate, which is then bolted to the large face plate of lathe. The work is then done with an ordinary bor-

ing tool. The boring need not be particularly smooth, but must be true, and of the same size from end to end, namely $1\frac{3}{8}$ ". Ends should be faced off to 2" length of bore. The next thing is to drill two $\frac{1}{4}$ " holes through the pole pieces parallel with the armature shaft and $1\frac{3}{8}$ " from the centre of it. To insure getting these right, the best way is to make a jig, which will also be used in drilling the bearing yokes which must be spaced exactly the same. Take a piece of iron and turn it to fit the bore of the field magnet, and drill a $\frac{1}{4}$ " hole through the centre of it. Next take a piece of flat bar steel say $\frac{3}{4}$ " x $\frac{1}{2}$ " and $3\frac{1}{2}$ " long, scribe a centre line on flat side and drill three holes as per drawing of yokes. Drill two more holes between for rivets.

Put a piece of $\frac{1}{2}$ " steel through centre hole and through hole of round piece. Spot through and drill the two small holes, and rivet or screw the two together. The jig is then ready for use. Put the disc in field magnet bore, turn so that the centre line is parallel with the base, clamp in place and drill the holes through pole pieces. These are for the side rods that support the bearings. If a suitable counterbore is available, both ends of these holes should be counterbored out, but this is not really necessary. This completes the work on the field magnet.

The bearing yokes should be filed fairly true on the back side of the end bosses, and then put in a 4-jaw chuck, two jaws holding on to the ends and the other two gripping the sides back of the central boss. The outer bosses may now be faced off, and the centre boss turned to $\frac{1}{2}$ " diameter, faced off and drilled and reamed to $\frac{1}{2}$ " for the bearing. The yoke is then turned over in chuck and the back of all three bosses faced off. Then take out of chuck, put on the jig with pin through centre holes and drill the side rod holes $\frac{1}{4}$ " diameter. Small oil holes may now be drilled and if desired, tapped for oil cups and the bearings are finished. The side rods are merely two 6" pieces of cold rolled steel $\frac{1}{4}$ " in diameter, threaded with a die, $\frac{3}{8}$ " on each end; thread $\frac{1}{4}$ " No. 20. The brass sleeves which serve as distance pieces will be described later.

The armature will now be taken up. First get some of the softest sheet iron, smooth and free of scale. Have a thsmith cut from this enough 2" squares to make a pile 2" high when pressed together. Stack these up, hold them even with clamps, (wooden hand screws will do) and drill a $\frac{1}{4}$ " hole through the middle of them. Then clip off the corners with hand shears making them roughly octagonal. Now get two pieces of $\frac{1}{4}$ " soft steel, 2" square, drill and tap holes in the centre with standard $\frac{1}{2}$ " thread. The shaft is made of a 7" piece of 9-16" or $\frac{3}{8}$ " machinery steel which should

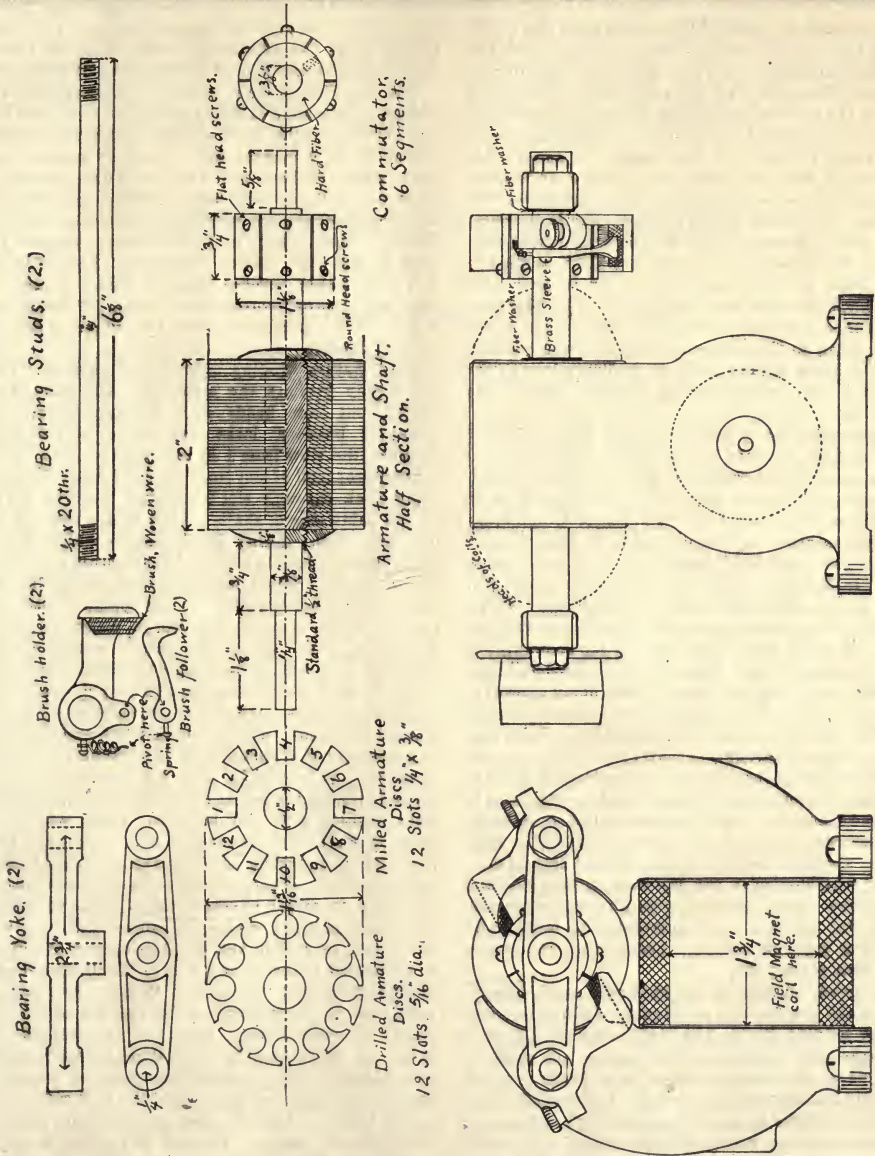

be centered, turned down to $\frac{3}{8}$ " for 2" on each end and the middle $\frac{1}{2}$ " diameter. Thread the $\frac{1}{2}$ " portion for about $\frac{1}{2}$ " at each end with a die (standard) and screw on one of the $\frac{1}{2}$ " pieces of steel. Hold shaft up-right in a vise and string on the armature discs, first shellacing them or else putting thin shellaced paper

between them. Put on the other $\frac{1}{2}$ " end piece, and screw up very tight, using a wrench and holding by the lower disc, not by the shaft.

The corners of the $\frac{1}{2}$ " pieces may now be cut off with a saw, and the whole put in lathe and turned off to 1 13-16" diameter. This job of drilling and turning

80-WATT DYNAMO 1-10 H.P. MOTOR.

the discs may be avoided if punched discs can be obtained, but that is usually difficult. Now comes the slotting of the armature. Two ways of doing this will be given. The best way is to mill them, if a milling machine is available, or this can be done in a machine shop at an expense of 50 to 75 cents. There should be 12, $\frac{1}{4}$ " slots, $\frac{3}{8}$ " deep. If this cannot be done, a fair job may be done by laying out 12 holes on the end discs 3-16" from the outside, equally spaced, and taking care to get marks on the two ends exactly opposite. Holes 19-64" diameter may then be drilled from each end till they meet. The holes are then reamed to 5-16". Slots $\frac{1}{8}$ " wide may next be cut in each hole with a hack saw and smoothed with a file. The armature is then replaced in the lathe, and the end plates turned down to the bottom of the slots, and rounded off. The shaft is then finished to dimensions as per drawings. This completes the machine work on the armature.

The commutator is next in order. Take a piece of hard red fibre, or hard maple, which has been dried by baking in a slow oven, and drill a $\frac{3}{8}$ " hole through the centre. If fibre is used, this hole should be at right angles to the layers to avoid danger of splitting. Drive on an arbor and turn down to $\frac{3}{8}$ " diameter and face off both ends to $\frac{1}{2}$ " length. Cut a piece of brass tube $\frac{3}{8}$ " internal diameter, and $\frac{1}{2}$ " thick to $\frac{3}{4}$ " length, drive on the fibre and turn off ends flush. With a pair of dividers lay off the circumference into 12 equal parts and mark these lengthwise of the commutator. On each alternate line lay off screw holes 3-32" from the end. Drill and tap screw holes, being careful to make the holes radial. Drill clearance holes through the brass and tap the fibre with 4-36 tap. Take care not to drill quite through to centre hole of commutator or you may get a short-circuit. Countersink holes in one end of commutator for flat head screws. Put in all screws and saw through brass on the six lines between screws, sawing into the fibre about 1-32". Take off one segment and put a strip of hard fibre or mica covered with shellac in the saw cuts on each side and screw down again. Repeat with alternate segments. Let shellac harden, put commutator in lathe on an arbor and turn off smooth, except the end where round head screws are.

The brush holders do not need very much description. They are finished by filing up, drilling and tapping for binding posts, and pivot screws for pressure fingers, as per drawings. The brushes are made of short pieces of a regular woven wire brush, cut off obliquely on the ends as shown. The brush holders are soldered directly to the sleeves on the bearing rods. These sleeves are made of brass tube, 5-16" inside diameter, and about 1-16" thick. Pieces of $\frac{1}{2}$ " brass pipe, iron pipe size, are just the thing. If this is used the brush holders are drilled with a 13-32" drill which will just fit. The sleeves must be insulated from the frame by winding shellaced paper around the rods and putting mica or hard fibre washers under each end. This does not allow the brushes to be adjusted

by swinging around the commutator, but this is not necessary, as the commutator can be slightly turned on the shaft at first and no adjustment will be needed.

The machine is now ready to be insulated and wound. Cut a strip of heavy paper 12" long, and 1 $\frac{1}{4}$ " wide, cover it with thick shellac, and wrap it tightly around the field magnet core. Cut four washers from thick paper, or two from thin hard fibre, slit in one place and put on ends with shellac. Put field in a lathe by screwing one end on a cap screw or threaded piece of steel, held in a chuck and support the other on the back centre. Wind with 13 layers of No. 21 single cotton covered magnet wire. A layer of hard white cotton cord such as is used for chalk lines is put on for protection, and the whole given two coats of shellac.

The armature winding may now be taken up. First thoroughly insulate the slots, heads and parts of the shaft $\frac{1}{4}$ " out from heads with shellaced paper. Put armature between lathe centres for convenience. Number the slots from 1 to 12. Start winding at the commutator end of slot No. 1 crossing back head and bring back through slot 8, keeping the wire always on the same side of shaft. Wind in this way 5 layers of 4 turns each, taking great care to make the wire lie flat and straight in slots and as smoothly as possible on the heads. When finished, twist the two ends of coil together temporarily, at the point of starting. Double cotton covered wire No. 18, American gauge, should be used. When first coil is complete, turn armature half around and wind a similar coil, beginning in slot 7 and coming back in slot 2. Each coil occupies two slots. When first two coils are complete, test for "grounds" with an electric bell and batteries, or a magneto if available. In like manner, wind coils in slots 3-10 beginning in 3, 9-4, beginning in 4, 5 12, and 11-6, beginning at 5 and 11. Test for grounds after winding each pair of coils. When winding is done, soak all coils thoroughly with shellac and bake in a slow oven, taking care to leave oven door open to avoid burning. When cool the coils may be connected up ready to attach to commutator. Take the *outside* end of coil in slot 1, scrape off cotton and twist with *inside* end of coil in slot 3. Outside end of coil in 3 is connected to inside of coil in 5. In like manner go around armature. There will then be six terminals which are to be fastened under the six round head screws on commutator. After testing machine so as to be sure everything is right, these connections may be soldered. The machine may now be assembled and tested. Connect one end of the field coil to each brush holder. Connect the machine with three or four cells of battery. It must be run as a generator in the same direction it runs as a motor. If it sparks, turn the commutator slightly one way or the other on the shaft.

The field magnet may be finished in black enamel if desired, and any other finishing touches the builder may fancy can be added. The winding here given will give 10 volts at 3000 R. P. M. and a current of 8

amperes may be safely used, or more for a short time. No pulley for driving has been described. This should be about $1\frac{1}{2}$ " diameter and $\frac{7}{8}$ " face for a $\frac{3}{4}$ " flat belt. It should have a flange on side toward the machine to keep belt from catching should it slip and run off.

The cost of materials for this machine is about \$2.50 if the builder can make his own patterns. If castings are bought, of course the cost is a little higher. A machine of this capacity and of equal efficiency is worth at least \$10.00 when complete.

HOW TO BUILD A SAIL-BOAT.

CARL H. CLARK.

V. Fitting Centreboard and Finishing Cabin.

The foundation may now be removed from under the boat, and she may be supported upon blocks and shored upright. At this time it will be well to put in place the remaining bolts in the mast step. The stem also should be planed down to follow the surface of the plank, leaving the face only about $\frac{1}{4}$ " wide, which face is fitted with a half round galvanized iron band, extending well down on the keel. The top of the stem is cut off about $\frac{1}{4}$ " above the deck and trimmed down to a tenon about $\frac{3}{4}$ " wide. The keel under the after overhang is also to be trimmed down to the surface of the plank and smoothed off to follow the same angle.

The skeg is of 2" oak fitted to the curve of the underside of the keel. The after end is plumb and is rounded out to admit the rudder post after being thinned down to $1\frac{1}{2}$ " thick. The forward end extends to the end of the centerboard slot and is rounded up as shown in Fig. 13. At the forward end a rivet may be driven, but elsewhere it must be fastened from above by lag screws driven through the keel. This skeg must be nicely fitted and be well fastened so there will be no tendency to work sidewise. The rudder stock is $1\frac{1}{2}$ " diameter of galvanized iron of the proper length to reach from the bottom of the skeg to about 3" above the standing room seat. There are four or five $\frac{1}{2}$ " holes drilled through it to take the fastenings for the wood blade, and at right angles to these a $\frac{1}{2}$ " hole is drilled at the top to take the tiller bolt. A tube is provided which is a turning fit for the stock and has a threaded end. A block is fastened on the top of the keel, as shown in Fig. 13, and a hole is bored of proper size to allow the tube to be screwed in, which should be done after smearing the threads with lead. In order to be sure that the tube is screwed in perfectly plumb, the rudder stock should be inserted, and the lower end held firmly while the tube is being screwed into place with a pipe wrench.

After the centerboard box is built the floor of the cabin and standing room can be laid. The floor beams are about 2" x $\frac{7}{8}$ " spruce; forward and aft of the centerboard box they run across and rest upon the frames, the ends being beveled off. In the way of the centerboard box the beams must, of course, be cut and strips, as shown in Fig. 13, are fastened on to the box

with screws to take the inner ends of these beams. The flooring of both cabin and standing room is of $\frac{1}{2}$ " pine laid in straight boards. The middle boards are left loose to give access to the space below. Around the outside, next to the side of the boat, it is fitted to shape. A strip should be laid also on the on the slant of the frame and fitted to the curve, to prevent articles from sliding down under the flooring.

The sidelights in the cabin trunk are about 12" long and 4" wide, and of elliptical shape. They are cut out with a compass saw, a small hole being bored to allow the cut to be started. The inner edge is rounded and on the outer side a rabbet about $\frac{1}{2}$ " wide and $\frac{1}{2}$ " deep, is cut around. Into this rabbet the glass is set and the corner filled with putty. A pair of screw ventilators about 3" in diameter, set into the trunk on the forward end, will be found to give good ventilation and are not expensive.

There should be a transom or berth fitted on each side and across the forward end of the cabin, about 6" high, and 2' wide, at the after end, tapering towards the bow. A board is left loose in the top, giving locker space below. It may be desirable to cover the frames on the inside of the cabin with thin sheathing, if it is intended to use the boat for cruising, as this will protect somewhat against the dampness and moisture. A door should be fitted to the forward bulkhead, opening above the transom, and fitted with hinges and latch.

The opening in the cabin roof is now to be trimmed out to the third beam, making an opening about 2' long and 2' wide. The after bulkhead is finished out to make the opening the same width; the lower edge of the opening being a few inches above the standing room floor. The edges of the bulkhead around this opening are lined with a casing about $3\frac{1}{2}$ " wide, with a ledge all around, against which the cabin doors will close; this is shown in Fig. 13, and would be best made with a rabbet on the outside to fit over the edge of the sheathing.

The slides and hatch on the top of the cabin are made as shown. The slide pieces are $4\frac{1}{2}$ " high at the after end tapering to 2" at the forward end and are about 4' long. They are provided with a groove on

their inside faces $\frac{1}{4}'' \times \frac{1}{4}''$ about $\frac{1}{4}''$ down from and parallel with the upper edge. The outer corner is rounded off. The cross pieces of the slide are provided with a projection which fits the groove in the side pieces and allows them to slide.

The boards of the top of the slide are $\frac{1}{4}''$ matched and laid fore and aft. The beams are cut on a camber considerably greater than that of the cabin roof as shown in Fig. 15. The middle beam should be quite thin in order to pass over the top of the casing at the forward end of the opening. The aftermost cross piece should be in such a position that when the slide is closed it will be just even with the ledge on the casing so that the doors will close against it when they are shut. The opening in the roof inside the hatch is cased up with $\frac{3}{4}''$ stock along the sides and across the front, as in Fig. 13; at the after end the casing should make a good joint with the vertical door jambs, and across the forward should extend high enough to overlap the forward cross pieces of the slide and keep out spray and wash. When this work is neatly done it adds much to the appearance of the boat. The cabin doors would best be bought, as they are rather difficult to make and does not cost much if bought at the proper place. They must be rounded at the top to fit under the slide, and must be cut out to fit around the centreboard when the latter is drawn up.

An oak top is to be made for the centreboard casing with a neatly rounded edge and a slot at the after end to allow the board to pass through. A folding table leaf about 9' 6'' long and 12'' wide may also be hinged to this top piece, folding down against the box when not in use. The cabin can be fitted with such additional lockers, and shelves as the fancy of the builder may indicate. The standing room seats are built about 15'' above the floor, and about 12'' wide outside of the coaming. They rest upon cross braces, the outer ends of which are supported by turned posts. The seat across the after end is arranged to give support to the rudder tube by a block or by other means. If desired, the space underneath the side seats may be enclosed by sheathing and fitted with removable doors, forming good locker space, in which case the bulkhead across the after end need extend only down to the level of the seat. If the seats are open underneath, a removable door is fitted to the after bulkhead.

The rudder is $1\frac{1}{4}''$ thick at the stock and tapers towards the after end. The several pieces run parallel with the stock, and are bored with $\frac{1}{4}''$ holes to match those in the stock. Galvanized iron rods are then driven through and the whole set up tightly; washers are put on the outer ends of the rods, and both ends of the latter riveted, drawing the whole tightly together. A slot is cut to allow a strap 3-16'' x $1\frac{1}{4}''$ to be passed around the stock; the rudder is put in place, and this strap inserted and fastened to the deadwood with screws. It holds the rudder and deadwood together. A piece of flat galvanized iron is also fastened on the bottom of the keel under the heel of the

stock to support it and prevent grass or ropes catching between. The tiller is of oak and has a plate on each side extending back past the rudder head. Holes are drilled to match the one in the rudder head and a bolt passed through.

The centreboard is built up of narrow boards held together with $\frac{3}{4}''$ galvanized iron rods. The after side must be shaped on a circle, with the pin at the forward end as a centre. The board may be about 2'' shorter than the box to give some clearance. The lowest board should be of oak and the others of hard pine. The rods should be about 8'' apart. It will hardly be possible to run each one all the way through, but they should be as long as possible, and where one stops the next one should overlap it to preserve the strength. It will add to the strength and appearance of the board if it is shod with $1\frac{1}{4}''$ half round galvanized iron; if this is not done, a piece of lead weighing about 20 lbs. should be set into the lower corner to sink the board. The hole for the pin at the forward end ought to be lined with metal to avoid wear; a rowlock socket set in flush with the surface will answer excellently. The hole in the box sides to take the pins must be bored in about the position shown in Fig. 13. The board is put in from below and the bolt passed through the two sides and the centreboard. Under the head of the bolt and under the washer on the opposite end a piece of rubber packing should be placed to keep out the water. A rope is attached to the after corner of the centreboard to lower it and haul it up. The board should be placed in its highest position and a hole bored just above the top of the centreboard casing, through which a pin may be inserted to hold the board up when not in use.

The planking and deck should now be planed and finished. As little should be taken off as possible. A smoothing plane, set fine, should be used, and the planks should be planed until they are perfectly fair and smooth. The corner at the bilge should be slightly rounded and also the corner of the covering board should have the sharp edge taken off, otherwise it will be apt to chip out. The planking and decks (if bright) should next be calked with cotton. Cotton for this purpose comes in balls already prepared. It is forced into the seams with a "calking iron" a sort of flat chisel shaped tool. The seam is first coated with paint. A thread of the cotton then started in the seam and forced in by hammering the "iron" with a mallet, gradually moving along the seam and working in a small loop of the cotton at short intervals, the size of the loops and their frequency being governed by the size of the seam. It is advised that the amateur, if possible, visit some place where he can see this done, as more can be learned that way than by a large amount of description. Calking is a rather particular piece of work, and care must be used not to force the calking too tightly, as there is some risk of loosening the plank. The edges of the plank may be raised somewhat by calking; if so, a light shaving may be taken off. The whole surface of the plank

may now be thoroughly sandpapered; the seams filled with putty and given a coat of paint. The deck, if canvassed, and also the housetop, is painted at the same time. If the deck is laid in strips it may be puttied and painted if desired, but the neatest way is to fill the seams with marine glue and varnish it. This marine glue is a preparation somewhat like tar, and requires to be melted and run into the seams with a ladle. It is allowed to harden and the surplus scraped or planed off. The whole surface is then given a coat of shellac and two coats of good varnish.

It will be necessary to strike in the waterline, the easiest way of doing which is as follows:—at the required height forward and aft a horizontal straight edge is fastened. The boat being on an even keel, one person sights across the two straight edges and a second places a pencil on the boat in such a position as to be in line with the two edges when sighted by the first. In this way, a series of points are obtained through which a curve is drawn with a batten. It is advised that the waterline be struck about 2" higher than that in the design, as it is advisable to have it

show a little, and it also prevents the side paint fowling as quickly. The outside should have a final coat of paint, and the bottom be covered with some form of anti-fowling or copper paint, the latter being put on after the topside paint.

The remainder of the bright work, cabin trunk, coaming, slide, doors, etc., should now be given a coat of shellac and two coats of varnish. All varnished work should be first coated with shellac, as it fills the grain and makes a better surface. The after bulkhead may be varnished if desired, but it is advised that the standing room floor and seats be painted as it wears better. The hole for the mast is about 5" diameter. Before cutting the mortise in the step the boat should be placed with the waterline level, a plumb-line is dropped from the centre of the mast, thus locating the centre of the mast on the step. The mortise is about 4" long and 1½" wide. For ballast, iron is probably the most available material, although small stones in canvas bags may be used if necessary. It is put in place after the boat is afloat and ready for final trimming, and in the position to bring her to trim.

PRINTING FOR BEGINNERS.

FREDERICK A. DRAPER.

VII. Job and Advertisement Composition.

To select and arrange types in such a way as to produce a well balanced, properly accented and artistic result requires skill which is not attained in a few weeks or months. Only by the careful study of materials and all the better forms of printed matter can the worker reach that degree of efficiency which would entitle him to be termed an "ad architect" as one well known printing house designates its workmen. To point out the way by which one may become competent in these lines is the most that can be attempted in these columns.

The beginner in job composition can adopt no better rule than to collect samples of the work of the leading printing houses in his locality, become a regular reader of at least one magazine devoted to the trade, of which *The American Printer*, published by the Oswald Publishing Co., New York City, and the *Inland Printer*, published by the Inland Printer Co., Chicago, Ill., are the two likely to be of most value to the beginner. In both of these magazines are departments devoted to critical reviews of job and advertising composition, and the merits of specific examples afford the reader the opportunity of learning the requisites of correct work.

An excellent book for the beginner is a "Book of Job Composition," published by the Oswald Publishing Co., New York City, which gives 133 type designs submitted in a prize contest. It is a book of 40 pages

and costs only 50 cents, and is well worth the money to any beginner. A similar book is published by the Inland Printer Co., Chicago, Ill., and is mailed for 40 cents.

The most prolific source of examples of good advertisements is that of the leading popular magazines, the advertising pages of which are worthy of the most careful and continued study. It will be found, however, that the reader will be able to acquire the ability to do skillful work only after becoming thoroughly familiar with each and all the different faces of type with which he has to work; this familiarity meaning the value which each face has in design, strength of color and artistic effect in combination with other faces.

One error quite common to the beginner is the disposition to use too large a size, filling up about all the available space with type matter. As experience is gained, the value of "white paper" or clean spaces will be learned; smaller sizes of type with suitable margins will be found much more effective than the monotonous sameness of crowded matter.

The use of rules, borders and ornaments is to broaden a subject, and too closely related to the peculiarities of the particular work in hand, to allow of specific directions. Here again, the popular and printers magazines will be found the best school in which to study. It will be noted that the present style, with

type, is to keep to as few faces as possible, different sizes being used to secure contrast, as well as extended, condensed and italic of the same series. From this it will be gathered, that, in equipping an office, the selection should favor the different sizes of one series in preference to the same number of fonts divided among different faces. The owner of one newly equipped office, to keep the first cost as low as possible, adopted the expedient of alternating sizes between two series of about equal measure, filling in the balance of the series as the means permitted or demands required. The object in doing this was to give to the printed work the appearance of having been done in a more perfectly equipped office.

The assortment of type in an office which caters to the general trade, even if only on small work, must include two or three series of both extended and condensed faces and a few sizes of an extra condensed series will be found very useful. Two or three "poster fonts" (25 pounds) of Modern or Old Style type for

solid matter will also be needed; in fact, the amount which can be profitably invested in what may be considered as really necessary type and materials, can easily be made to reach the \$1000 mark, and then not have much of an outfit. Included in such a list would be the following series, which will be found in the catalogues of the larger type manufacturers:

DeVenne.	Gothic.
DeVenne, Condensed.	Gothic, Condensed.
DeVenne, Extended.	Gothic, Extra Condensed.
DeVenne, Italic.	Gothic, Italic.
Jensen.	Gothic, Extended.
Jensen, Condensed.	Howland.
Post.	Latin Antique.
Post, Condensed.	Bold Face.

The series may not, in the catalogues of the different manufacturers, be designated by these names, as manufacturers have their own trade names for type faces which are alike. On the other hand the faces, while similar, are not always just the same, which must be kept in mind when ordering.

JUNIOR DEPARTMENT

For the Instruction and Information of Younger Readers.

ELEMENTARY MECHANICS.

J. A. COOLIDGE.

IV. The Wheel and Axle.

Although there are nominally six simple machines, the lever, the pulley, the wheel and axle, the inclined plane, the wedge, and the screw; and although these machines are generally very different in appearance, they may be divided into two classes, according as the machine turns about a fixed point or pivot when the

Weight arm, may be seen to be true in these machines. The inclined plane, on the other hand, finds its modifications in the wedge, and in the screw which is a movable inclined plane in spiral form.

The wheel and axle is like a lever in this; first, that it turns about a pivot; and second, that the power and weight are attached to it at different distances from the pivot, thus making a long and a short arm. The lever is limited in its actions in that the weight can be lifted only a short distance, while in the wheel and axle, the weight may be lifted a much longer dis-

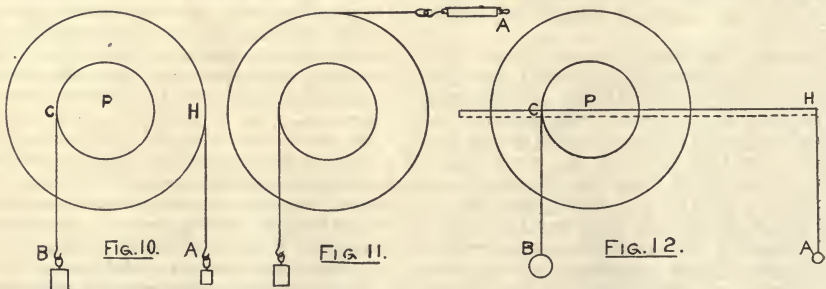

weight is moved, or the machine is made to slide under the weight, or the weight is made to slide or roll over the surface of the machine. Thus the lever may include the wheel and axle, and the pulley, and the laws of the lever:—Power \times Power arm = Weight \times

tance, in some cases many feet.

For experimenting with the wheel and axle much time and trouble may be saved, if one has an old bicycle wheel and its bearings. The large wheel with the tire removed furnishes an excellent wheel and

the axle, or better a slightly larger axle made from a spool, may be made to furnish an attachment for the weight to be lifted. As comparatively few have such conveniences we will give directions for making a wheel that will serve our purpose. An axle may be made from a rod of brass or smooth iron 6" long, and 5-16" diameter. A wheel 3" diameter should be carefully cut from some $\frac{3}{8}$ " stock, and two pieces 3 $\frac{1}{4}$ " diameter cut from some $\frac{3}{8}$ " stock should be glued or nailed, one on each side. This will make a grooved wheel. A better one can be made if one has access to a turning lathe, or if one can cut one out of a roller of some kind. A wooden rolling pin costing five cents will furnish wheels for a dozen. A smaller wheel 1" in diameter and with the larger one must be centered and fastened with shellac or cement to the metal axle. The axle should be mounted in a frame or box at least 15" high. Two stout linen threads smooth and flexible should be used. Fasten one to the rim of the wheel and wind it around the wheel four or five times so that it shall unwind left handed, as can be seen at C, Fig. 10. The other should be fastened to the smaller wheel or axle and should be wound in the opposite direction as in A of the same figure.

At A and B fasten two of the weights we have made and used in our former experiments making them balance. If any difficulty is found in doing this, some small additional weight may be added either to A or B. Compare the weight at A with that at B. Compare also the distances RH and PC. Using the hand as an extra force pull down on A and measure the distance B rises while A descends 6". Also notice the speed with which A moves as compared with that of B. As the diameter of the wheels are 3" and 1", the radii, or distances PH and PC are as 3 to 1; the distances moved by A and B should be 6" and 2"; and the speed of A should be three times that of B. If the weight B is not found to be three times the weight A the difference is due to friction.

To determine the friction in the experiment, let us use, instead of a weight at A, the spring balance and pull in a horizontal direction as seen in Fig. 11. The average of the force necessary to raise B and that required to let it descend slowly will be the true force A. Compare this with the weight used before at A. Try several cases of equilibrium between A and B, using forces at A, of 8, 16, 24 oz. as the force and record in tabular form.

A. 8 oz.	B oz.
16 oz. oz.
24 oz. oz.

Does $A \times PH = B \times PC$? If this is so the law of the lever is again verified, and may be called law of the wheel and axle. The power \times the radius of wheel = the weight \times the radius of axles. The ratio of the force needed, to the weight to be moved may be found by dividing the radius of the wheel by the radius of axle. The brakes on cars and the steering apparatus on board a vessel are about the only illustrations of the wheel and axle one is likely to see;

but many modifications are in use and can be seen far more frequently. The crank and axle is the same machine with this exception that all of the wheel is removed except one or two spokes, and that the force is applied at the end of a spoke. The power in some cases may be applied anywhere along one of the spokes, thus allowing the power arms to be of different lengths. In many machines the crank is curved so that all semblance of a wheel is gone. The derrick, windlass, capstan, brakes on electric cars, and many other contrivances are examples of the wheel and axle.

Take two pieces 12" long, $\frac{1}{2}$ " wide and $\frac{3}{8}$ " thick, and nail them to the wheel just used so as to make two arms as shown in Fig. 13. If we consider the original wheel as the hub of an enlarged wheel, and PH as a spoke of this wheel, we may experiment with this as a crank and axle. The pivot P is the same, the cord at C holds the weight B, and the power A is attached 12" from P. $PH \div PC =$ the ratio of weight to the power. As the power arm PH is so much larger than PC the weight is very much larger than the power.

On the bottom of our box directly under B fasten a screw eye. Make the cord CB shorter and hang on the lower end a spring balance, fastening the hook to the screw eye in the floor beneath. Hang on the end A just weight enough to hold the balance vertical. Place extra weights at A, in each case recording the pull exerted on the spring balance. The balance records for us the weights that can be lifted at B by the forces used at A. Try forces of 2, 4, and 6 oz. at A and again see whether the law holds true.

Some of the values of the crank and axle may be seen from the following examples:—Here are some men moving a house. A horse is attached to the end of a bar that turns an axle set vertically and around which a rope is being coiled as the horse turns the axle. The other end of the rope is fastened to a house set on rollers. If the bar to which the horse is attached is 10' long, and the pull of the horse after allowing for the loss by friction, is 1000 lbs. the value of the power \times the radius of the wheel, i. e., the length of the bar, is $10 \times 1000 = 10,000$. As the weight moved \times the radius of axle must equal this sum, if the radius of axle is $\frac{1}{2}$ a foot, $\frac{1}{2} \times$ the weight moved = 10,000 and the whole of the weight moved = 20,000 pounds. Of course the weight represents the pull exerted on the house, and as the house rests on rollers, this pull must be able to move a weight many times larger. With a loss from friction of 50%, the weight would be doubled, or 40,000 lbs. The force exerted by the horse, in a real case of house moving, is increased several times by a system of pulleys.

The sailors are hoisting an anchor. Each at the end of a capstan bar is pushing with a force of 50 lbs. If the bar is 8' long, the total force of 100 lbs. will make the value of power \times length of crank, $100 \times 8 = 800$. If the radius of the capstan is 6", $\frac{1}{2} \times$ the weight moved = 800, and the whole weight = 1600

lbs. With a larger force from each man, with more men and less friction, much greater weights can be lifted. Sometimes the power exerted on the crank is not applied directly to the weight, but the circumference of the axle is a toothed wheel and fits or "meshes" into the circumference of a larger wheel. The second wheel moves more slowly than the first and may be attached in the same manner to a third. These gear wheels allow an immense gain in power although there is considerable loss from friction and the weight is moved very slowly. In transferring power from one set of shafting to another, the friction of the belt on the circumference of the wheels transfers the motion from one to the other. By making one wheel large and the second small a very great speed may be obtained. For example, suppose the large wheel have a diameter of five times the smaller, then the speed of the smaller will be five times the larger. By adjusting these differences any speed desired may be obtained.

HOW BOYS CAN EARN MONEY. II.

CUTLERY AND TOOL SHARPENING.

Any boy who can secure the use of a grindstone or emery wheel can engage in this business, which, if industriously followed up, will be found quite profitable. In most any place a sufficient number of families can be visited, orders obtained for sharpening kitchen knives, scissors, hatches and axes; also if sufficiently skillful, planes, chisels and other tools. Some practise may first be necessary with such of these articles as may be found at home, as future orders will depend upon satisfactory work with those received the first time. A good whetstone will have to be used to complete the work done upon the grindstone or emery wheel. Care must be used on cutlery to grind evenly and not too thin on the cutting edge.

With scissors a slight bevel is given, and the edge must be very even and smooth. Examine a new pair to get the correct shape. The charges should be moderate, five cents for knives and ten cents for scissors.

ELECTRICITY BY EXPERIMENT.

III. INDUCTION.

The magnets used to perform the previous experiments were made of steel, and incidentally it may be stated that the harder the steel, the longer will the magnet retain its strength, and also the greater the current required to first magnetize it. Soft iron, on the other hand, while becoming quickly magnetized, also quickly parts with magnetism when the exciting cause is removed.

EXPERIMENT 8.

Obtain a short piece of soft iron; the core from the magnet of an old electric bell if one is to be had, or at some blacksmith or machine shop a piece of $\frac{1}{4}$ " Nor-

way iron. Place the piece of iron on a piece of smooth writing paper and sift the iron filings over and around it. Observe that there is no attraction of the filings to the iron. Hold one end of the bar magnets near the piece of iron, but not touching it or the filings. It will now be seen that the piece of iron attracts the filings; that the magnet has *induced* magnetism in the piece of iron. By holding one of the suspended needle magnets near the piece of iron, but on the opposite end from the bar magnet, it will be observed that the iron has two poles. Test for polarity with the suspended magnet, changing the poles of the bar magnet.

Place between the bar magnet and the piece of iron a strip of thin glass. Observe that the magnetism is still retained in the piece of iron. Other non-magnetic substances such as wood, rubber, brass, etc., may likewise be placed in the same place as the glass, and yet not interfere with the magnetic induction of the piece of iron, showing that magnetism will act through all known substances with the single exception of iron. Place a strip of iron cut from a tin (tinned iron) can in place of the glass and note that the piece of iron is no longer magnetized. The strip of tinned iron acts as a screen to divert the lines of magnetic force.

The piece of iron, under the influence of the bar magnet, becomes quickly magnetized. This property is known as the *permeability* of the iron. Should the piece of iron have been only moderately soft, it would not entirely part with the magnetism after removing the magnet; that remaining being known as *residual magnetism*, a property of value in dynamos which will be more fully considered in subsequent chapters. The steel magnet, which holds its magnetism has what is known as *retentivity*. These various properties should be thoroughly studied, as they have an important bearing on the functions of many pieces of electrical apparatus and machines.

The Morse Twist Drill & Machine Co., New Bedford, Mass., have issued a new catalogue of 250 pages, in which their well known tools, together with many new ones are presented with a most excellent typographical appearance. This catalogue should be on file in every manual training school and machine shop in this country, and will be mailed upon request. In this connection a suggestion is made that those sending for it include 10 cents to cover postage, thus showing a disposition to meet manufacturers, in part, in what is a heavy expense for circulating information of decided value to all users of tools.

Catalogue No. 18A, wood working machinery, and 18 B, "Star" lathes, issued by the Seneca Falls Mfg. Co., Seneca Falls, N. Y., give detailed information relative to the well known and excellent machines manufactured by this company. The "Star" lathes have made for themselves an enviable reputation, being well designed, well made and finely finished. The other machines made by this company are equally efficient and favorably known where used.

AMATEUR WORK

A MONTHLY MAGAZINE OF THE USEFUL ARTS AND SCIENCES

Vol. III. No. 8.

BOSTON, JUNE, 1904.

One Dollar a Year.

A SAILING DORY.

CARL H. CLARK.

This dory is of the usual type used for sailing. The dimensions 18 ft. long by 5 ft. wide, make a boat which, while not very heavy has still enough stability to carry sail well and be safe.

The method of building is very nearly the same as that followed in building the power dory already described, and the directions there contained will be found of much use in building this boat.

The outlines of the moulds are to be taken from the cuts, which are to the scale shown below the outlines of the moulds. The bottom is of oak $1\frac{1}{4}$ " thick, made up of several widths, if necessary. The necessary dimensions for the bottom are given, so that the outline can easily be drawn. The joints in the bottom should be close on the inside and open about $\frac{1}{8}$ " outside for calking; the several pieces are fastened together with cleats $1\frac{1}{2}$ " square, taking care not to place any where the moulds or bent frames are to go later.

The stem is 2" thick, and if a natural crook cannot be obtained, should have the grain run diagonally, so as to have as little cross grain as possible; in this case, as before, a false stem is put on later; the inner stem being the only one put into place at present. It is fastened to the forward end of the bottom with galvanized boat nails or rivets, care being taken to have it point straight fore and aft, and at the proper slant.

The stern board is laid out from the outline given. In transferring lengths from the drawing the distance to be measured can be taken either with dividers or marked upon the edge of a card and laid on the scale of feet and inches, and the length read off. This length is then laid off full

size with a rule; by taking a series of points any outline of moulds, stern, sternboard, etc., can be laid out. The sternboard is of 1" oak and is held in place by the stern knee, which is cut from $1\frac{1}{2}$ " stock with the grain running the long way. It is fastened with galvanized boat nails or small rivets. Considerable care should be taken to adjust the angles of the stern and the sternboard, as they have great effect upon the final shape of the boat. The sternboard also should have cleats nailed across the inside.

The bottom is next set up on blocks or horses at the proper height for easy working—the centre block should be 3" lower than the end ones, and the bottom sprung down that amount and held by shores from above.

The moulded frames are next gotten out of natural crook pieces, if possible, to the shape shown. These shapes can be obtained by measuring, using the scale provided. They are of 1" stock 3" wide, and extend to the centre line. There are two similar pieces for each frame and they are fastened together by a floor piece nailed on the back of the two parts, and a piece is also nailed across the tops. When the frames are completed they are fastened in place on the bottom, the under side being bevelled somewhat to allow them to set upright on the slightly sloping bottom. They are fastened from below with brass screws. A ribband should also be run around the tops to keep them in line. The edges of the moulds where the plank is to rest are to be bevelled off slightly to allow the plank to rest fairly upon them.

The plank is $\frac{5}{8}$ " thick, of either pine, cedar or

cypress—cedar is rather to be preferred, but either of the others will serve. It should be obtained in boards as wide as possible, as there is considerable "spiling" or bend in the plank. The garboard, or lowest streak, is put on first, about as before described; the edge of the bottom bevelled to the varying angle of the lower flat of the moulds. The flat up to the first knuckle should be divided up into two planks, making the lower one very narrow amidships and carrying the ends as wide as possible; this takes out a large amount of the "spiling" and makes the second plank much narrower and easier to fit. The lower planks will need to be in two lengths with well-fitted joints. The operations of fitting the planks are about the same as in the power dory—the lap at the edges being $1\frac{1}{4}$ ".

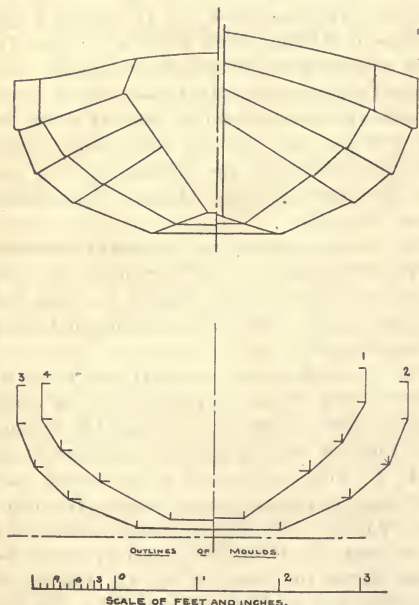

The planks above should be put on in one piece if possible, but in any case, joints in adjacent planks should be well apart. The top streak should be carried $\frac{3}{4}$ " above the tops of the moulds to admit the gunwale, and the lower edge of the top streak should be beaded. The planks at the stern are cut square across, even with the stem and the false stem fastened on the outside.

The gunwale is $3'' \times \frac{3}{4}''$ and is bent around inside the top streak and on the top of the moulds. It is tapered at the ends to about 2" to make it bend in more easily, and is fastened through the top streak with boat nails, and into the tops of the moulds with long nails. At the bow a breast hook is worked between them, and at the stern a knee is fastened to the sternboard.

Between each two moulds two binders, or light frames about $1'' \times \frac{5}{8}''$ are bent in, extending well on to the bottom. They are first well steamed and then forced well into the corners, to follow the planks as far as possible. They are fastened with nails clinched on the inside and by nails driven into the bottom.

The centre board slot is cut in the position shown on the plans, $1\frac{1}{4}''$ wide and exactly in the centre of the boat. It should be noted that the uprights at the ends extend down through the bottom, and allowance must be made for them in cutting the slots. The uprights are $3'' \times 1\frac{1}{2}''$ fitted to the ends of the slot. The centreboard box is then built upon them. The joint between the box and the bottom must be carefully made to be tight. The lower board of the box should be of oak $1\frac{1}{4}''$ thick, fastened to the bottom with heavy screws driven from below, with a layer of lead and a thread of cotton in the joint. The upper boards of the box can be of pine or other stock and should extend to the height of the seats. The top of the box is covered with a board lengthwise. The centreboard is of $1\frac{1}{4}''$ stock, the lower board being oak. It is of proper size to give an inch or so clearance all around and is through bolted with $\frac{3}{8}''$ iron rods. It is set into place and a $\frac{3}{8}''$ iron bolt put through for a pivot. At the after top end an eye is screwed in to take the rope to haul up and down, which rope passes out through a hole in the board covering the top of the box. If desired, a rod, such as is sold for the purpose, may be fitted to control the centreboard.

The wale which supports the seats is about 2" wide by $\frac{3}{4}''$ thick, and is bent around inside of and fastened to the moulds about 6" down from the top of the gunwale. The seats rest upon it and are placed as shown. They are of $\frac{3}{4}''$ stock and rest upon the wale just put in. The forward seat must be of 1" oak extra strongly fastened, as it supports the mast. It should have knees at the

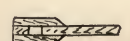
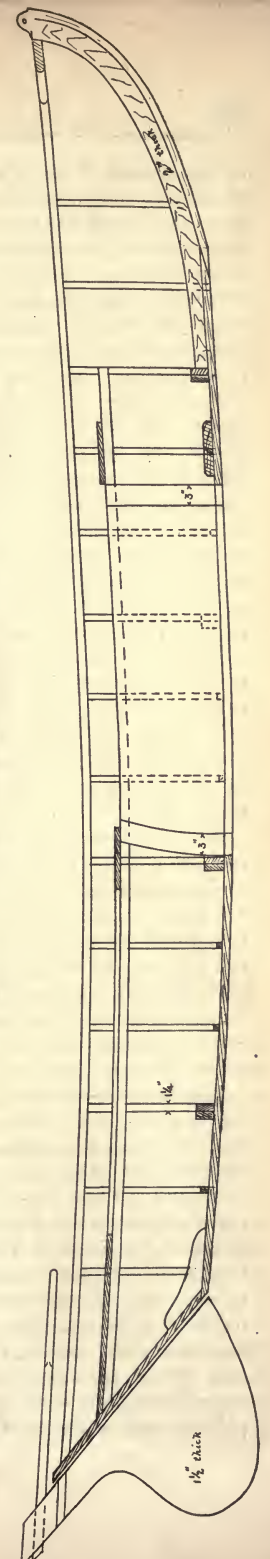
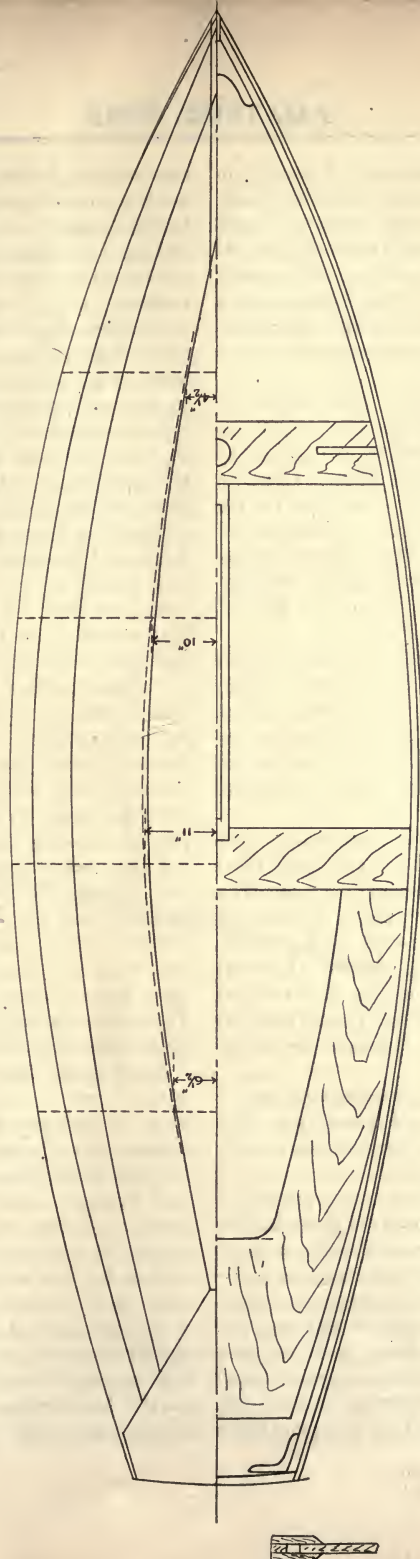
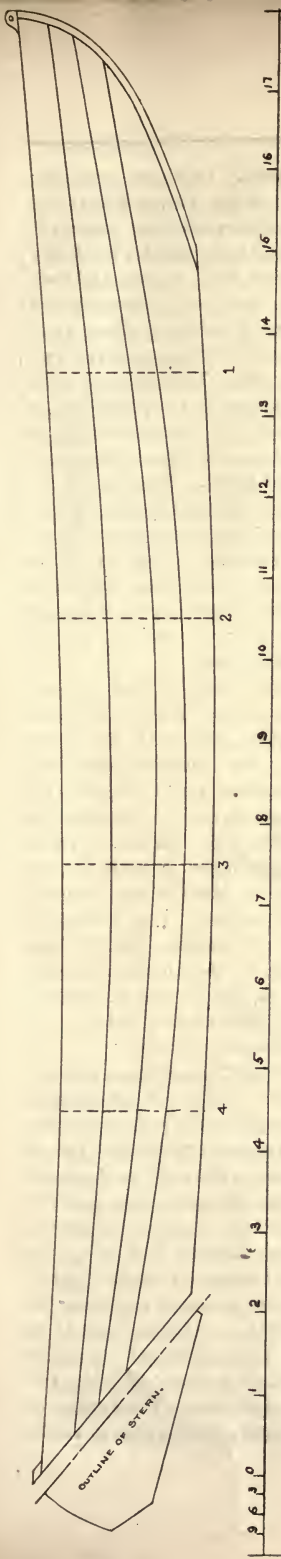

ends, fastened to the gunwales. A hole 3" in diameter for the mast is cut in the forward seat. It is to be noted that the cross seats are located at the ends of the centreboard box and fastened to it; which supports both the box and the seats. Directly under the hole in the forward seat a block $1\frac{1}{2}$ " thick is fastened, with a mortise 3" long and $1\frac{1}{2}$ " wide, to take a corresponding tenon cut in the foot of the mast.

The rudder is of oak $1\frac{1}{2}$ " thick, shaped as shown. To allow the insertion of the tiller the top is cut off and separated from the rest by about 2" and a block fastened on each side with screws to form the socket. The tiller fits the socket in the rudder head and extends well inboard over the stern seat. To fasten the rudder in place the ordinary rudder hangs, sold by dealers in yacht supplies, are to be used, as the rudder is unshipped when not in use.

The top of the stern board is rounded off, and the top of the stem finished off to a curve similar to that shown. To the top of the stem an eye bolt must be made fast to take the stay for the jib, and a pair of chain plates are to be fastened on the sides about 8" back from the mast to take the side stays.

It is very desirable to fit the boat with one or two pairs of rowlocks, as there are many times when oars are useful. To support the rowlocks a flat piece of oak about 2" wide by $\frac{3}{8}$ " thick can be fastened around on the top of each gunwale, and this may be varnished if desired. Gratings are made for the bottom by nailing thin strips of wood on to cross pieces, and are shaped to fit the bottom between the cross timbers and are easily renewed for cleaning.

The rig in common use on this type of boat is the "leg of mutton" type with a small jib. It is the simplest rig possible; very safe and easily shipped and unshipped.

The sail and spar plan shows the length of the spars and the several dimensions of the sails. The mast and boom are of spruce; the former is 18' long, 3" in diameter at the foot, running nearly the same to within about 3' of the top, then tapering to 2" at the top. The boom is $13\frac{1}{4}$ ' long, $2\frac{1}{2}$ " diameter in the middle, tapering to 2" at each end. These spars may be gotten out of small spruce trees, such as are commonly sold for flag poles, or they may be worked out of square stock

obtained at a lumber yard. In either case they are first worked square to the proper size and to the right taper; the corners are then taken off, making them octagonal. The corners are gradually worked off into the round with a plane and then smoothed up. They are finally sandpapered smooth and given a coat of white shellac; after which they are again smoothed up and given two coats of good spar varnish. To fasten the boom to the mast a gooseneck should be purchased, as it is the neatest in the end. It consists of a band which encircles the mast and is fitted with a socket to take the end of the boom. The end of the boom, where the prong of the gooseneck is driven in, should be fitted with a galvanized iron band, driven on to prevent splitting. The top of the mast should be cut down somewhat smaller to form a shoulder. A galvanized iron band having four eyes on it, is slipped over the top of the mast and bears on the shoulder.

The mast is fitted with three stays of $\frac{3}{16}$ " galvanized wire rope, one on each side, and a forestay leading down to the stem. All the stays should be made fast to the masthead, either by splicing, which is the neatest and strongest way, or by bending the end down next to the standing part and winding tightly with marline. Where the rope passes through an eye it must not be bent sharply, but must be fitted with a thimble, such as is sold for the purpose. The forestay is fitted with hooks and turnbuckles, which allow the mast and rigging to be unshipped easily when desired and set up tightly with no trouble. The eye on the back of the mast is to take a single halliard block to raise the mainsail.

For the sails, what is known as "heavy drill" is to be used. It comes usually in 30" widths, about 16 yards being required for both sails. The dimensions of the sails are shown, but they should be made somewhat shorter—about 6" on the boom and mast—to allow for stretch. They may be made by sewing the pieces together edgewise, making a sail with no "bights," as they are termed, but it is advised to make a single bight in each cloth, as it is far stronger and stretches much less. To do this, a "bight," or tuck, should be turned over in the middle of the cloth and run the full length; it is about $\frac{3}{4}$ " wide, and should be sewed on each edge. The outline of the mainsail should be laid out on a floor in chalk,

according to the dimensions given, and then shortened, as above directed, on boom and mast. The strip of cloth is laid on the outline and cut off about 3" outside of and parallel with the line. The cloth may then be turned over, the angle just cut being correct for the end of the next cloth. It is then cut at the other end and again turned over for the next width. In this way all the cloths are cut, allowing each cloth to overlap the preceding one to the line which is formed about $\frac{3}{4}$ " from the edge. The next work is to sew the several cloths together, with the edge of one cloth just even with the line near the edge; sewing along one edge and then turning over and sewing the other edge. This is continued until all are sewed together. At the same time a double hem should

fastening, and eyes are worked on the hoist and foot about 12" apart. The procedure in making the jib is just the same, except that the bolt rope is on the stay and lower edges and, if desired, the jib may be made first to get the practice for making the larger sail. As many mast hoops, 4" in diameter, are to be obtained as there are eyes on the hoist of the mainsail, and are shipped on the

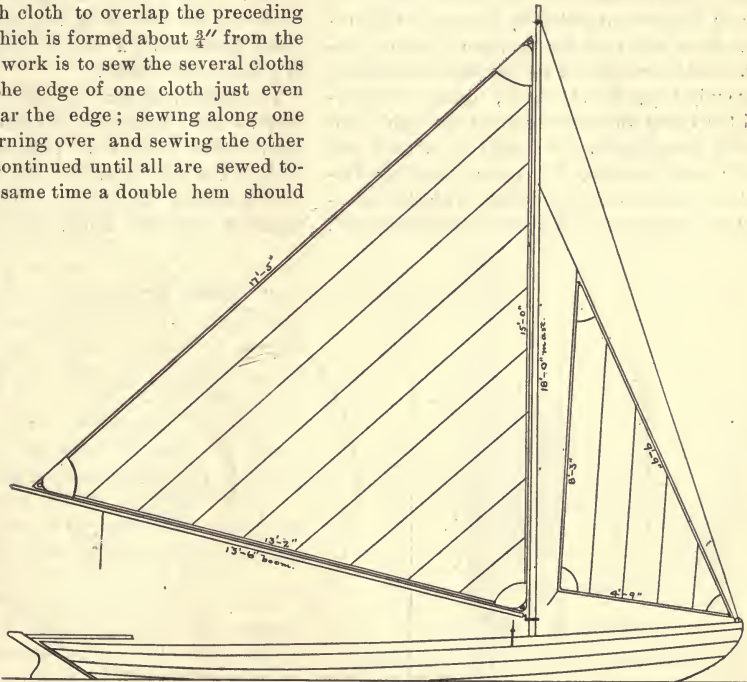

be turned in the edge of the outer cloth and double sewed.

The sail is then laid on the outline and trimmed off to within 2" of the true shape, the edge then turned over $\frac{1}{2}$ " and again turned over $1\frac{1}{2}$ ", which brings the sail the correct size and gives a double edge at the edge of the hem. It is then sewed at the inner and outer edges of the turn, and perhaps once between. The corners should be rounded. At the corners triangular reinforcing patches should be sewed to take the strain. The sail must now be bound with a bolt rope along the hoist, and the foot with about $\frac{1}{8}$ " rope; it is sewed on with a sail needle and twine. An eye, or round thimble is sewed on to each corner for

the mast. The eyes on the hoist of the sail are then fastened to the hoops, and the foot of the sail is laced to the boom with a small cotton line. A piece of 9-thread manila rope is used for a halliard, and a corresponding piece fastened to the boom to serve as a main sheet. A snap hook is fastened to the eye in the lower corner of the jib and snapped into an eye on the stern. The pulley for the jib halliard is fastened to one of the upper mast hoops. The mainsail halliard should be brought down to a cleat on one side of the mast and the jib halliard one the other. A jib sheet should be led from the eye on the jib aft on either side of the mast. Cleats for main and jib sheets are to be placed where most convenient.

PATTERN MAKING FOR AMATEURS.

F. W. PUTNAM.

IV. Face Plate—Hand Wheel—Core Pulley and Core Prints.

The wood turning lathe is a most useful machine to the pattern maker in shaping to the required form many of the common types of patterns. The lathe adapted for pattern work should be strongly framed and steady, in order to withstand the vibration resulting from the high speed at which it is driven. It should be of good and durable workmanship, the parts requiring frequent adjustment being provided with the quickest and simplest means of accomplishing that end.

means. In the case of a regular wood turner, the work many times does not require turning to exact dimensions, a smooth finish being usually of greater importance.

The pattern maker generally turns small work just as the regular wood turner would, with a skew chisel beveled on both sides. In the case of heavy work, especially when turning "built up" patterns, the work is frequently fastened securely in a lathe, and a sliding rest, similar to

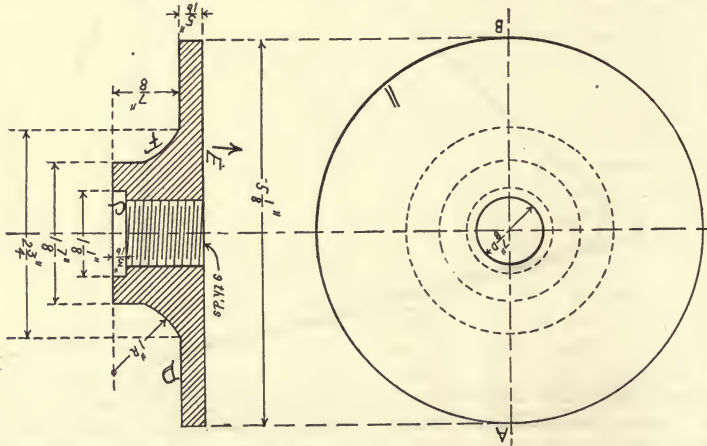

FIG. 13. FACE PLATE. FINISH ALL OVER.

The operation of pattern turning for large patterns is carried on in a rather different manner from the ordinary work of the wood turner. The pattern maker does not ordinarily use a tool ground on both sides and held sidewise for finishing, as does the wood turner, but instead, employs a thick chisel ground on one side only, with which he scrapes the work by firmly holding the chisel flatwise on the rest. Pattern makers turn in this way because the work must be approximately round and of exact size, the finish being then of minor importance, and also because it is possible to produce this finish later by other

that employed in the metal working lathe, placed before it, the turning being done by means of tools held in the rest.

The patterns described in this chapter can all be turned on a lathe with a 6" swing, and, therefore, the amateur pattern maker will find that the 6" "Amateur Bench Lathe" offered as a premium by the publishers of "AMATEUR WORK" will serve admirably for this work. I shall assume that the reader has carefully followed my series of articles on "Wood Turning for Amateurs," and has become familiar with the elementary principles of wood turning as applied to the

various exercises described in that above series of articles, and shall confine myself to a few special directions for the turning of the following patterns.

FACE PLATE.

Fig. 13 is a drawing of a finished face plate. The pattern will be of the same shape as the face plate, which is to be finished all over. Use a piece of clear dry pine for this pattern, $5\frac{3}{4}$ " square and $1\frac{1}{2}$ " thick. First plane one side perfectly true and on this side mark out a circle $5\frac{5}{8}$ " in diameter, cutting the block down to the circle just marked with a turn saw, if available, or approximating the circle with a back saw and paring chisel. This block is to be fastened to a screw centre plate with the planed side against the plate, this planed surface becoming the top surface of the finished pattern.

The threaded hole is to be drilled out and the thread cut after the casting has been made. The little recess at *C*, Fig. 13, will, however, be cored out in the mold, the recess cut in the pattern leaving a small green sand core projecting up from the bottom of the mold. In turning this pattern remember that *E*, Fig. 13, is the top side of the pattern, and also that the necessary allowances for finish and shrinkage, as well as a little draft, must be made. The surface *D* must be kept straight and should be tested with a scale or try square. Use a round nose chisel for turning the large fillet at *F*, Fig. 13.

Having brought the pattern, as nearly as possible, to the required size and form with the turning tools, it is necessary to consider those final processes which so much add to the appearance and smoothness of pattern work. The first of these processes is *Sandpapering*. The beginner often hurries his work thinking that sandpaper will hide the defects, and bring it all right. This idea is wrong, for, let a pattern be ever so carefully shaped and turned, if the sandpaper is carelessly applied, the sharpness of its outline will be destroyed and very likely its size and shape will be noticeably changed. So, while we respect sandpaper, let us respect our tools more, and bring the pattern to as near the form required as is possible with the cutting tools, and then let the sandpaper be applied, not by folding it together and rubbing it upon the work, but by considering the outline we intend to finish and pre-

paring a piece of wood for a *rubber*, to correspond to the shape. A flat surface requires a flat rubber, a convex surface a concave rubber, etc.

Having turned and sandpapered the pattern, as already directed, the next proceeding is to stop up all holes or cracks that are not to show in the casting, with either beeswax or putty. This is a simple process but it takes a good deal of practice to determine just the proper amount necessary for each hole or crack, so as not to require much time in trimming off the surplus. The wax is formed into a worm like shape, and with the heated point of a knife, not hot enough to make the wax run freely but only to cut it easily, the wax is pressed into the hole.

The third and last of the finishing processes is the application of the spirit varnish as mentioned in the last article. Varnishing lathe work cannot be done while running the lathe, but after the work is varnished, running the lathe will hasten the drying.

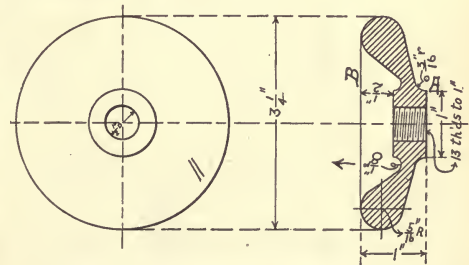

FIG. 14. HANDWHEEL.

Fig. 14 shows a finished hand wheel, the threaded hole being bored and the thread cut after the casting has been made. The pattern will be of the same shape as the finished casting, the necessary allowances being made for finish and shrinkage, *B*, Fig. 14, being the top surface of the pattern when molded. For this pattern use a piece of clear dry pine $3\frac{3}{4}$ " square and $1\frac{1}{2}$ " thick. First plane one side perfectly true and on this side, mark out a circle, $3\frac{5}{8}$ " in diameter, cutting the block down to the circle, following directions previously given. This block is to be fastened to a screw centre plate, the finished side *A*, Fig. 14, coming against a back piece which in turn comes against the face plate. If the screw centre plate has a long centre screw use a back piece, as indicated above, the block being then

clear of the plate by an amount equal to the thickness of the back piece. This will enable the turner to finish the back curve near *A*, with a $\frac{1}{4}$ " round nose chisel.

If the centre screw is not long enough to permit the use of a back piece, the front side and the edge of the pattern may be finished and then chucked so as to finish the back surface, or the pattern may be turned from a block. In this latter case the extra amount of thickness will serve as a back piece and may be reduced with a parting tool to 1" diameter, thus allowing of the

casting is made. The right end view in this figure is a half section drawing showing the three pieces from which the pattern is made. Do not forget the necessary allowances for finish and shrinkage, and in turning this pattern be very liberal with the draft allowance, particularly with the surface enclosing the spaces at *E* and *F*, Fig. 15. *A* is the top surface of the pattern when molded, and the arrow indicates the direction in which the pattern is drawn from the mold. The spaces at *E* and *F* in the finished casting are left by a green sand core, formed as

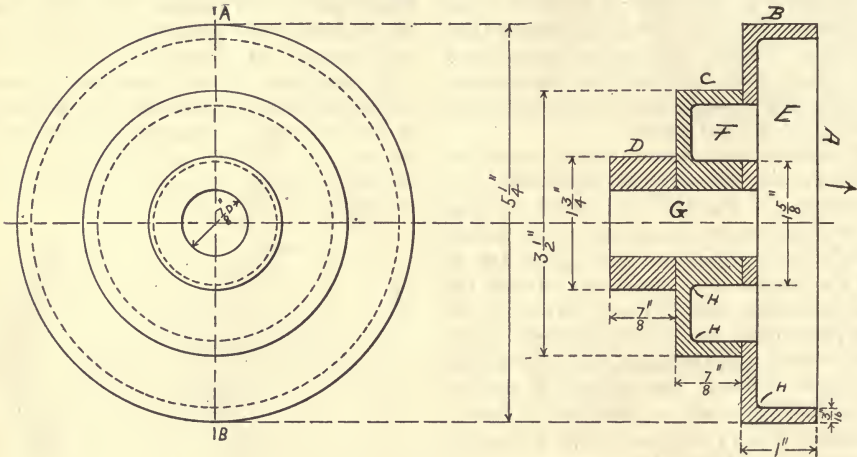

FIG. 15. CONE PULLEY. FINISH ALL OVER.

finishing of the back of the pattern with the $\frac{1}{4}$ " round nose chisel, after which the pattern is to be sandpapered and nearly cut off with the acute point of a skew chisel, care being taken not to hit the centre screw. This surface would then be the surface *A*, Fig. 14, and should be carefully trued up.

In turning this pattern templates should be cut out and used to enable the turner to easily obtain the desired outline. The molding of this pattern, as well as those previously given, will be taken up in a later chapter.

CONE PULLEYS.

This is a much more difficult pattern to make, as it is to be built up from three blocks, is more difficult to turn, and requires great care in molding. Fig. 15 represents the shape of the finished casting, the hole *G* being drilled out after the

part of the *cope*, and right here let me say that I assume that the pattern maker has carefully read my article on "Simple Castings in Type Metal," which appeared in a previous issue of AMATEUR WORK. I shall use the terms *cope*, *nowell*, etc., as defined in that article, many times in describing the next few patterns.

This pattern is to be built up from three blocks, *B*, *C*, *D*, Fig. 15, planed true on both sides to the thicknesses as given below. The block *B* should be planed to $1\frac{1}{4}$ " in thickness cut round, $5\frac{1}{2}$ " diameter. The block *C* should be planed to $1\frac{1}{16}$ " in thickness cut round. $3\frac{1}{2}$ " diameter. The block *D* should be planed to $1\frac{1}{16}$ " in thickness and cut round to 2" diameter. Using hot glue, fasten the pieces together, being sure that each is carefully centred, and clamp in a vise to dry. The block *D* may also be fastened to *C* with $1\frac{1}{2}$ " No. 16

wire brads, care being taken to drive these brads straight, after which set in the heads $\frac{3}{8}$ " with a nail set.

The glued block when thoroughly dry is to be fastened to a screw centre plate, the surface *A*, Fig. 15, coming against the plate. The outside surface of the pulley is then turned, care being to keep the shoulders straight and to give the belt surfaces the necessary draft. Having finished the turning of the outside surfaces, sandpaper them carefully and remove block from screw centre plate.

The pattern is next to be chucked, the chuck preferably holding the pattern at the surface *C*. This will require a chuck about $2\frac{1}{4}$ " in thickness. The chuck is fastened by screws to a face plate. Care must be taken in cutting the recess which is to receive the pattern, not to get it too large. In turning the surfaces enclosing the spaces at *E* and *F*, Fig. 15, notice that small fillets are to be turned as indicated in the figure at *H*. These surfaces which, as previously stated, will require a liberal allowance for draft should be very carefully sandpapered. The pattern is then to be finished as previously described.

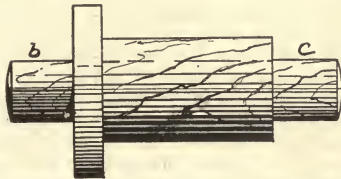

FIG. 16. PATTERN WITH CORE PRINTS.

In a previous article I have spoken of the *green sand core*, and shall now briefly describe *baked sand cores*, first giving the following standard definition of cores by Rose: "Cores are projecting bodies of sand, either left in the mold by the pattern itself or else made in a separate device called a core box. They are placed, after being dried, in position in the mold. The purpose of a core of the latter description is to leave a hole or recess of such a peculiar shape that it is impracticable to make the mold of the necessary conformation by the use of the pattern alone. The use of these cores also permits us to modify the shape of a pattern that would otherwise be difficult to mold."

When it is not possible then, or when it is not

convenient to have the cores left by the pattern, they are formed in separate devices called *Core Boxes*. The core box is considered as a part of the pattern or patterns with which it goes, the pattern and core box together forming a *set*. In

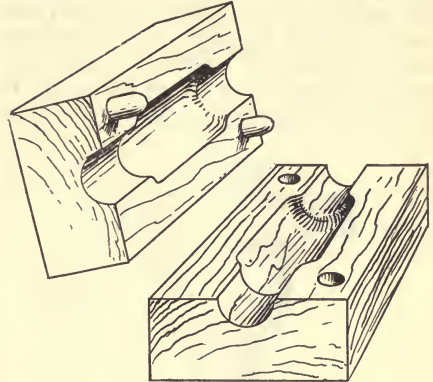

FIG. 17. CORE BOX.

Fig. 16 is shown a pattern having core prints at *B* and *C*. The core box for making this core is shown in Fig. 17, and the mold with the core in place is shown in Fig. 18.

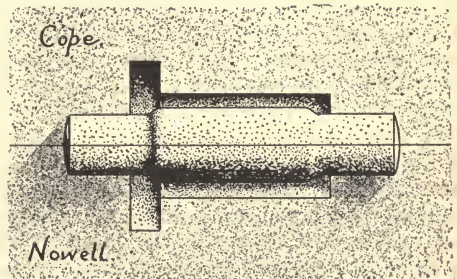

FIG. 18. MOLD WITH CORE.

When a large number of standard cores of the same size are required, as, for instance, the small round cores used in making holes through the hubs of pulleys, and in other works of a similar character, metal core boxes are often used.

Core Boxes require just as much care in the making as do the patterns, and just as much attention must be given to their shape, durability and finish. The shape of the pattern is usually very nearly like that of the required casting, ex-

cept that it may have no holes or openings in it. The openings in the core box resembles the openings in the casting.

CORE PRINTS.

When cores are made in core boxes and placed in the mold it becomes necessary to support them in such a manner that there can be no possible chance for a change of position during the time the mold is being filled with the hot metal. To give the core this support, special recesses are

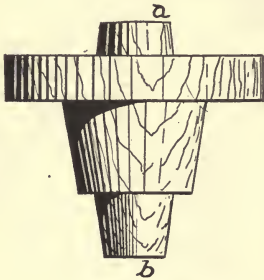
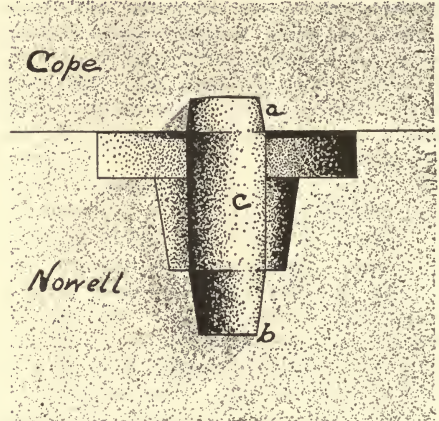

Fig. 20 shows a mold made by the patterns shown in Fig 19. The ends of the core *C* fit in the recesses left by the core prints, as shown at *A* and *B*.



FIGS. 19 AND 20. PATTERN AND MOLD SHOWING CORE PRINT.

made in the mold to receive them. These recesses are made by attaching pieces called *Core Prints* to the pattern, as shown at *A* and *B* Fig. 19. These core prints should be colored differently from the rest of the pattern, so that the molder may readily distinguish where the cores are to be placed. For our work we will use orange shellac for core prints and the inside surface of core boxes.

As cores are always a source of more or less trouble to the molder, these prints should be made of such a shape and size as will give the least trouble to the molders. The core should exactly fill the recess left by the core print, and the core print should be made large enough so that the recess left in the sand will not be crushed out of shape by the weight of the core or the action of the molten metal. Large core prints for vertical cores should be tapered, so that the trouble of withdrawing the pattern from the sand may not be increased by their presence, and also that the core may be easily placed in the mold. Core prints leaving recesses for a horizontal core should have plenty of draft in each end to facilitate in drawing the pattern readily from the sand.

Outside illumination at the St. Louis World's Fair is to be carried out on a grand scale. The contracts provides for 300,000 incandescent lamps for lighting the exhibit places, grounds, and architectural features of the exposition proper, but not for state, national, and private concession buildings. Twelve thousand lamps alone are to be placed on the Palace of Education, this affording an excellent setting for night effects. The illumination of the grounds is to be carried out on very ambitious lines. Each monumental standard will carry twenty four incandescent lamps so distributed that twelve will hang on each arm of the supporting post. The lighting of the inside of the buildings will be accomplished entirely with arc lamps.

German papers state that the French Government is at present considering the question of the use of white lead and other lead mixtures for painting houses. A committee of the Chamber of Deputies has been appointed to investigate the matter, and Mr. Breton, one of the experts, has been authorized to publish the results of his investigation in pamphlet form. He condemns the addition of white lead to paints and all colors containing it, declaring them to be poisonous in a large degree, both for the workmen and for the inhabitants of a house painted with lead colors. He recommends the use of zinc white instead, which, for surfaces exposed to the sea air, is also much more practicable. He expresses the opinion that the absolute disuse of white lead has become an imperative necessity.

TOOL SHARPENING DEVICE.

F. A. DRAPER.

Unless one has had considerable practice, the sharpening of wide chisels and plane irons on a emery wheel is quite likely to be an unsatisfactory operation, the difficulty being to get a perfectly straight edge at an even bevel. The easily made device here to be described will enable the most inexperienced to do good work without requiring particular care on the part of the operator. It can be attached to a lathe and used with an emery wheel mounted on an arbor, or by means of proper supports easily adapted to a reg-

screws to the ends of *C*. Holes are bored in the upper front corners of the ends *E* to receive large, round-head screws put into the ends of the piece *F*.

The tool holder consists of the piece *F*, 3 $\frac{3}{4}$ " long, 2" wide and $\frac{1}{2}$ " thick, and the piece *G*, 3 $\frac{1}{4}$ " long, 2" wide and $\frac{1}{2}$ " thick. The left ends of pieces *F* and *G* are held flush, and holes for small bolts with thumb nuts *N* are bored $\frac{3}{8}$ " from each end of *G*. The heads of the bolts are then fitted into the under side of *F*, and washers placed un-

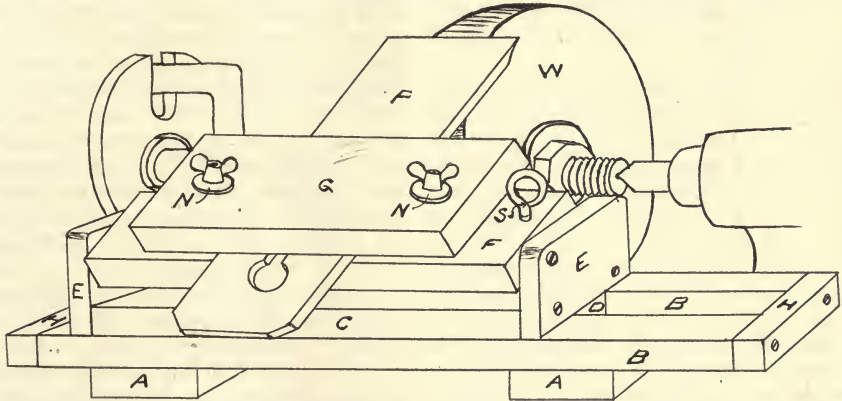

ular grinding wheel or grindstone. The dimensions given are dependent upon the size of the lathe or wheel, but can easily be figured out to any desired size. It is best made out of maple, or other medium hard clear grained wood.

The pieces *A*, are supports, the rear ends being bolted to the top of the bed. Strips 2" wide and $\frac{3}{8}$ " thick will be quite strong enough. A rectangular frame, *B* and *H*, made of pieces $\frac{3}{4}$ " square and 8 or 9" long, the centre space being as full as $\frac{3}{4}$ " wide, is then fastened with screws to the pieces *A*, the screws being put through from the under side, one in each piece *B*. The slide is made of the piece *C* 4" long, 2 $\frac{1}{4}$ " wide, and $\frac{3}{8}$ " thick; the piece *D* a scant $\frac{3}{8}$ " square and 4" long and two pieces *E*, 2 $\frac{1}{4}$ " long, 2" high and $\frac{1}{2}$ " thick. The piece *D* is glued to the centre of the under side of *C*, the ends *E* are attached with long

under the thumb nuts on *G*. A large screw eye *S* is then put through the right end of *F*, on the rear side, the lower end resting on the piece *C*. Two screws are then put through the end pieces *F* into the centre of the front ends of *F* forming bearings for the tool holder. The tool *P* is put between the pieces *F* and *G*, fastened in place by tightening the thumb nuts *N*, and then adjusted to rest on the emery wheel *W*, at the desired angle by means of the screw eye *S*.

In sharpening the tool, the slide is pushed back and forth, graphite being used to lubricate the surfaces of *B* and *D*. About the only precaution to be observed is that of adjusting the ways *B* and the tool so that they will be square with the arbor of the emery wheel, the bevel on the tool being regulated by the distance it projects from the holder towards the emery wheel.

LANTERN SLIDE MAKING.

R. G. HARRIS.

V. Clouds in Lantern Slides—Combining Slides for Cloud Effects.

Lantern slides without clouds, are now as rarely seen as are prints without them. At the present time the percentage of landscape negatives that do not show clouds in them is small indeed compared with what it was fifteen years ago. The orthochromatic plate, coupled with the use of a light filter makes the retention of clouds in landscape negatives an easy matter; and when even these are not used, the fact that nine-tenths of the exposures made are shutter exposures accounts for the great prevalence of clouds in the negatives of today.

The lantern slide worker, more than any other, should make a special effort to obtain his negatives with clouds in them, for by so doing he will obviate a large amount of subsequent work. Perhaps in his landscape negatives clouds already exist, but owing to their greater opacity they do not show well defined in the print, in such a case the sky portion should be carefully reduced with ferricyanide or persulphate until the clouds assume an opacity of equal printing value with the landscape portion. In some cases the sky portion of the negative exceeds in density the landscape portion by only a small amount, and it is not desirable to interfere with the opacity. Where this is the case, the landscape portion should be screened during exposure, when making the slide, so that the denser may have a few seconds additional exposure. There will, however, always be a certain proportion of slides which necessitate the introduction of clouds from other negatives, so that it is essential for the slide maker to be proficient in the methods whereby clouds are introduced into slides that show no trace of them.

Two methods are generally available; the clouds may be printed on a separate lantern plate from a specially made cloud negative, and this cloud slide used as a cover glass, or they may be printed on the same plate as the landscape portion in the camera by double printing. These two methods will now be described in de-

tail, preference being given to the first, or "cover-glass method."

It is essential that the slide maker, who has the prospect of much landscape work before him, should be well stocked with cloud negatives of every description, specially taken and developed, so that he can at any time select a suitable cloud effect for any particular landscape. I recommend that prints from these cloud negatives be mounted in a rough album, and the time of the day when the negative was taken, with the compass direction of lighting, be written underneath. There will then be no danger of bizarre and contradictory cloud effects being shown on the screen. In these cloud negatives no portion of the landscape should show; if it is impossible to avoid obtaining some portion when taking the negatives, the landscape should be blocked out by gumming some non-actinic paper upon the reverse side of the negative.

Having obtained a lantern slide of the landscape portion see that the sky part of the slide is represented by absolutely bare glass. If the negative has its sky portion blocked out this will secure perfectly pure glass in the lantern slide, but should any deposit be apparent in the slide it must be cleared away by the application of the ferricyanide reducer, applied with a small tuft of cotton wool. The slide is washed and dried in the usual manner. To make the cloud portion, take another lantern plate, and, having selected a suitable cloud negative make a lantern slide of this. The cloud negative must be adjusted in the camera so as to occupy the position on the plate that will enable it to fit in the clear portion of the landscape. All that is necessary is to hold the landscape slide over the image of the cloud negative shown on the focussing screen, when it will be seen at once if the two correspond. Expose and develop, taking care to work under the same conditions as when making the landscape so that the colors of both may be the same.

On removing the plate from the fixing bath

and comparing it with the landscape portion it will at once be seen how nearly they correspond with each other. Here, now, is seen the value of reduction and intensification in slide work. Perhaps the sky slide requires a slight intensification to bring it up to the landscape portion, or it may be denser and require a brief application of ferricyanide reducer. Having made the two slides of equal opacity, place them back to back, with the edges of the slides even. It will at once be apparent whether the two dovetail into each other, or whether the sky slide overlaps the landscape slide and give a bad effect. Should the sky slide encroach on the landscape anywhere, take a tuft of cotton wool, dip it in the ferricyanide reducer, and, still holding the slide back to back, carefully remove the portion of the sky slide that overlaps the landscape. Do not use the reducer too strong, and see that none of the reducer reaches the landscape by capillary attraction.

When the slides are dry and bound film to film the sky and landscape portions should fit and form a perfect slide. This is the best method of obtaining clouds in lantern slides; but it has one drawback, when developing for warm colors it is not always easy to closely match the two slides. For this reason it is best, whenever possible, to expose the sky and landscape plates one after the other and develop them together. Another means of ameliorating the difficulty is to prepare a stock of sky slides during leisure moments, so that some variety may enable the slide maker to effect a match.

The second method, that of printing the clouds on the same plate as the landscape, is not quite so certain as the method just described. Having selected the cloud negative it is desired to incorporate with the landscape, a mask has to be prepared with which to screen the landscape portion during the exposure of the cloud negative. To prepare this mask, take a piece of non-actinic paper, lay it over the landscape negative, and holding the negative up to a strong light, roughly trace with a pencil on the paper the outline of the landscape where it comes against the sky. Cut out the landscape portion along this line so that two masks result, one for the sky and the other for the landscape. For convenience, the landscape mask may be gummed on a piece

of cardboard, leaving the outline of the landscape projecting beyond the stiff of the cardboard. The stiffening is an advantage, as it enables the mask to be held more securely by them and during exposure.

Place the landscape negative in the camera and expose on the lantern plate in the usual manner. Then remove the landscape negative and insert the cloud negative, taking care that it is placed in the same relative position that the landscape negative occupied. Now hold the cardboard mask in front of the cloud negative so that it covers that portion of the negative corresponding to the landscape negative. The mask requires holding about an inch away from the negative, and should be kept moving slightly above and below what would be considered to be the line of junction of the landscape and sky portions. It will thus be seen that the sky negative is vignettted into the landscape portion in the camera, so that both are obtained upon the one lantern plate. A little practice enables this to be done in a very neat manner, but this method is probably not so easy for the beginner as the one previously described.

It should be borne in mind that the same necessity exists in this second method for obtaining the landscape portion with the sky showing as clear glass, otherwise on removing the landscape negative and inserting the cloud negative a brilliant result will not be obtainable. If the sky portion of the landscape negative is not sufficiently dense to give freedom from deposit in the slide, that portion of the paper mask covering the sky should be roughly placed in position during the exposure of the landscape negative to insure this end.

Photography.

Another step in the direction of technical education has been made in the city of Dresden in the establishment of a school for locomotive driver apprentices. The purpose of the new school, which is managed in connection with the Dresden Technical School, is to equip men who are to become locomotive drivers. The school is for apprentices between 25 and 30 years of age who are employed in the Dresden car shops. Among the subjects taught are German, arithmetic, graphics, and the mechanism of locomotives.

Note the premium offer on the editorial page; many premiums can easily be secured in this way. Try it.

AMATEUR WORK

77 HILBY ST., BOSTON

DRAPER PUBLISHING CO., PUBLISHERS.

A Monthly Magazine of the Useful Arts and Sciences. Published on the first of each month for the benefit and instruction of the amateur worker.

Subscription Rates for the United States, Canada and Mexico \$1.00 per year. Single copies of any number in current volume, 10 cents.

TO ADVERTISERS.

New advertisements, or changes, intended for a particular issue, should reach the office on or before the 15th of the previous month.

Entered at the Post-office, Boston, as second-class mail matter
Jan. 14, 1902.

JUNE, 1904.

At the solicitation of many of our readers we have decided to offer premiums for the sale of single copies of the magazine:—To anyone selling 12 copies, the premium for one yearly subscription will be given. Anyone selling 25 copies may have their own subscription extended one year. It should be a very easy matter for many to secure a few orders for each issue of the magazine, and when the necessary number have been secured, obtain a premium. Should the desired premium call for the sale of more than 12 copies, a record will be kept and the premium sent when the number of copies are sold, necessary to secure it. Regular subscribers, desiring to secure premiums under this plan, may order the number of copies they find they can sell, remitting for same after delivery to customers, but within 30 days. Readers whose names are not on our subscription list should send money with order. Unsold copies cannot be returned, as handling them is liable to so deface them as to make them unsalable, so only the number should be ordered which can surely be sold. A little work each month will enable anyone to secure many useful tools, the turning lathe, or some other valuable premium. Try it.

Arrangements are being perfected for a considerable increase in the size of the magazine, and the opening of several new departments, all of which will increase the interest manifested by our readers in all sections of the country, and which we gratefully acknowledge.

Do not send stamps with orders during the warm season unless fully protected by gummed paper.

The most curious specimens of vegetable or plant life in existence are the so called "living stones" of the Falkland Islands. Those islands are among the most cheerless spots in the world, being constantly subjected to a strong Polar wind. In such a climate it is impossible for trees to grow erect as they do in other countries; but Nature has made amends by furnishing a supply of wood in the most curious shape imaginable. The visitor to the Falklands, says an American writer, sees scattered here and there singular-shaped blocks of what appear to be weather beaten and moss covered boulders in various sizes. Attempt to turn one of these boulders over and you will meet with an actual surprise, because the stone is actually anchored by roots of great strength; in fact, you will find that you are fooling with one of the native trees. No other country in the world has such a peculiar "forest" growth, and it is said to be next to impossible to work the odd shaped blocks into fuel, because the wood is perfectly devoid of grain, and appears to be a twisted mass of woody fibres.

Timing clocks electrically by the Western Union Telegraph Company of America is said to bring in a revenue of more than \$1,000,000. The company keeps 70,000 clocks going on correct time at an average charge of apparently a little more than a shilling a week each. The clocks are set at noon each day by an automatic arrangement connected with the great sidereal clock in the National Observatory at Washington. A few minutes before noon every day business over the Western Union wires is suspended, and operators through the country put their instruments in shape to form an unbroken circuit from the observatory to every place where ticks a clock to be electrically influenced. When the time ball strikes, the time message immediately flashes over the wires.

TELEPHONE CIRCUITS AND WIRING.

ARTHUR H. BELL.

I. A Simple Arrangement for Short Lines.

The subject of telephones and their application to private uses is a matter sparsely treated in electrical text books and technical publications. Much importance has been given, in such works as have been offered to the public, to detailed descriptions of the construction of various types of transmitters, receivers, and similar apparatus, from earliest days of experiment to modern times, and but little space has been devoted to the arranging of systems of easy practical communication between two or more distant points, with

tus possesses over another, but by what method any good type, of which there are scores in the market, may be connected together for house to stable, room to room, or factory to office service.

It is the purpose of this article to cover intelligently a number of circuits of value to readers in all parts of the country. Possibly many arrangements best adapted to one's specific needs may not be treated until later chapters, but it is advisable for the reader to follow all of the circuits as they are explained, thereby gaining a liberal un-

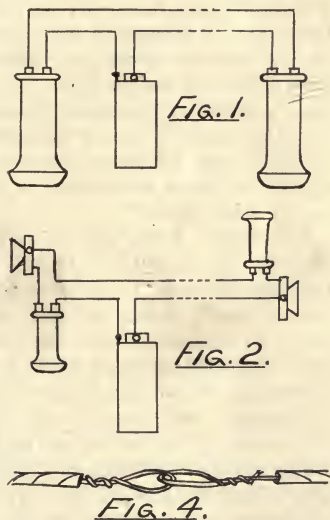

such diagrams of circuits as will help the non-technical reader to establish telephone service without the aid of a practical telephone electrician.

In this, and the following chapters, the ordinary transmitter or receiver will be treated purely as an article of commerce, for sale at reasonable prices and returnable as junk when rendered worthless by long service.

What interests the layman most, is not what distinctive electrical features one type of appara-

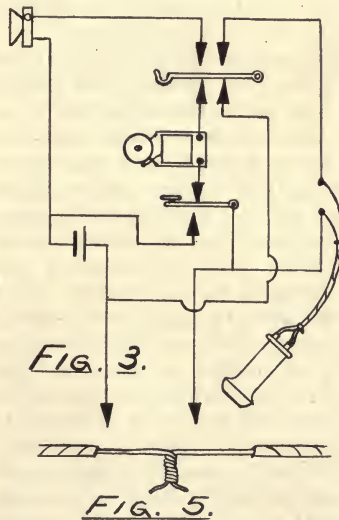

Understanding of wiring methods.

The most simple arrangement of the telephone is a circuit, Fig. 1, comprising two ordinary receivers and a cell of battery. Conversation by this method is limited to short distances and not worthy the trouble of connecting the apparatus except for experiment.

The next arrangement is the addition of a pair of transmitters to the circuit, as in Fig. 2. The same circuit, with battery at each end, will facilitate talking. This permits easy conversation for

quite a distance, but no means of signaling. It will be noticed that these circuits are closed at all times and consequently would wear constantly upon the battery supply if a switch to open the circuit were not inserted to prevent exhaustion.

A simple method of setting up instruments for practical usage between two points is shown in Fig. 3, where the length of line construction is to be limited to the distance over which an ordinary electric door bell may be operated for signaling. This arrangement is splendidly adapted to room to room or house to stable circuits, where the line length is less than 1000 feet.

This diagram represents the equipment of one station complete, if we spread it out before us for inspection. The hook is, perhaps, the most important part, as everything depends on the proper make and break of the contacts when the receiver is taken off and replaced. The receiver must be kept on the hook when not in use.

Let us now discuss the circuit piece by piece. One side of the line takes one side of the battery. The other terminal of the transmitter goes to one of the upper hook contacts. These upper contacts do not touch the metal hook until the receiver is removed. The second upper contact takes a binding post (not shown in the diagram), and after we have connected our flexible receiver cord to the receiver, one of the two ends is connected to this binding post. The other side of the receiver cord goes to a binding post connected with the other side of the line. With the receiver off the hook we are enabled to talk with and hear the party at the other end, because the circuit between transmitter and receiver is established by the hook after it goes up. Now, in signalling it is desirable to utilize the same sets of batteries, and the ringing circuit must be so devised that the downward contact of a strap key will place the battery in circuit across the line, thus ringing the bell at the other station as long as the key is depressed. The key, when restored, makes a contact with a contact point connected with one side of the bell, and the other side of the bell takes a contact point on the other side of the hook. The second under hook contact goes to the side of the line, where we started. It will be readily seen, with the strap key making upward contact and the receiver hook bearing on lower contacts, how a ring from the other end of the line will operate

the signal bell. The reader should trace out this circuit until it is fully understood. It is not advisable to operate this system with one side of line grounded; the circuit should be metallic, that is, consisting solely of wires from station to station, to get the best results.

Readers may purchase transmitters and receivers at electrical stores and arrange wiring and working parts inside of a small wooden box, being careful to solder all connections carefully.

It may be observed that no induction coils are used in connection with this set. (On systems designed for short distances the induction coil has no value.) Induction coils are wound and used to raise the transmitted voltage, so as to overcome line resistance. In a subsequent chapter a diagram utilizing an induction coil will be shown.

In placing wires between stations, within doors, a number of important rules of installation must be obeyed. Foremost among these is the rule to avoid at all times crossing of other wires and, in cases where it is absolutely necessary to pass over other circuits, to thoroughly protect your wires by extra thick layers of insulation, from any chance of cross due to direct contact, chafing, unexpected moisture, or breaking of wire or insulation of either circuit.

For interior construction, in residences where neatness and partial secretion of wires is essential, wire known as No. 16 or 18 paired annunciator or office wire may be used, but where wires are to be concealed from close inspection, as under floors or behind sheathing or plastering, strict observance of fire underwriters' rules and rules for wiring as established by municipal legislation is necessary. In cellars and damp places, or places likely to be damp at certain periods, the wire should be well protected by heavy, damp-proof insulation of rubber, or similar compound. In tacking wires to the walls, use as few tacks as possible and avoid setting one tack over two wires of a circuit.

In splicing two pieces of wire together, never make what has been styled a bell hanger's joint, Fig. 4, for such connections are not perfect conductors and would be an endless source of bother. Always scrape the copper wire clean and bright and twist the two ends firmly together and solder securely, Fig. 5; then insulate the splice with a layer of electrician's tape.

CURRENT REVERSER FOR SPARK COIL.

A spark coil is very incomplete without a commutator. One of a very simple kind, and much easier to make than the usual variety fixed to coils, is figured below. This is a modification of one illustrated in Mr. Hare's book on large induction coils, and on all fours with a reversing switch fitted by Carlisle & Finch, of Cincinnati, to their model motors and electric cars.

A is a piece of stout sheet brass, about $1'' \times 3''$; in the centre of this a hole is made to exactly fit a piece of brass tubing *B*, (triple tubing used by makers of fishing rods will do for this.) *B* is about an inch in length, and should be soldered to *A* and fixed upright. *C* is a piece of brass tubing $\frac{1}{2}''$ longer than *B*, through which it passes; it should make rather a tight fit in *B*. In one end of *C* fix, by soldering, a small brass bolt, the head of which should just go in the end of tube, and may there be fixed. At the other end of *C*, drill two holes exactly opposite each other, and large enough to take a piece of stout brass rod, *J* about $2''$, this also may be soldered.

D is a thick disc of ebonite. This is secured to the bottom end of *C* by, having drilled a hole, passing it over the brass screw and securing it with the nut. It follows that if the handle or T-piece be turned, the ebonite disc is revolved, anything mounted upon it being quite insulated. The T-piece should be fitted so that the ebonite disc is kept close to the plate *A*, and without shake. *E E* are two brass studs securely inserted at opposite sides in the under side of the ebonite disc. Securely soldered to each is one strand of the best silk and rubber covered twin flexible wire. The best way I think to do this is to get two pieces of the smallest gauge copper or brass tubing, $\frac{1}{8}''$, say. Drill a small hole near one end, and, having bared a strand of the wire, pass it through the hole and out at the end. Then plug this end with a piece of brass rod, and make a perfect joint with solder. The two studs, or short tubes, being done in this way, may then be securely fixed to the disc, as shown. They are, of course, perfectly insulated one from the other by the rubber and silk covering.

The brass platform *A*, is mounted on two wood mahogany blocks, *G G*, these again glued to a gas block. Two terminals are then attached, as shows, *H H*, and hard brass or German silver springs adjusted, *R R*, so as to make perfect contact with the studs *E E*, as shown in the plan, Fig. 2, where is shown the under side of the ebonite disc, the two studs, and the two springs pressing against them. Ebonite or wood handles are fitted to the T piece, and the protruding end of *C* covered with a little ebonite cap.

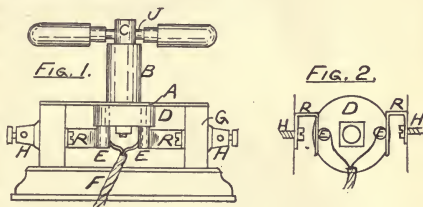

The twin wire is attached, one strand to the contact pillar, and the other one to one of the primary wires on the coil. The wires from the battery are then brought to the two terminals, *H H*. The handles being in a line with the base, as in the figure, a current passes, which current is reversed if the handles are turned the reversed way. With the handle set at right angles to the base the current, of course, is switched off.

Mr. Hare's remarks accompanying his design of switch may be quoted:—"In the ordinary commutator there are four joints where resistance may be found viz., at the two bearings of the cylinder, and at the two springs. These may be reduced to two, and the contact much improved."

British Journal of Photography.

A despatch from Caribo, Maine, says that a guide who has returned from Tiboqu , reports that Bald Mountain, in New Brunswick, has disappeared, its place being occupied by a lake of muddy water. The sinking of the mountain is supposed to be connected with the earthquake felt in New Brunswick and New England States recently. There have always been at the foot of the mountain springs of boiling water supposed to have a volcanic source. The guide's story is confirmed by a number of woodsmen.

A STORAGE BATTERY.

W. C. HOUGHTON.

The battery here described is of the pasted lead plate type and may be made of any desired capacity by using a greater or less number of plates. There are always an odd number of plates, three, five, seven, nine, etc., there being one more negative than positive. The "grid" or lead frame adopted, requires a mould, which may be of wood or iron. A wooden mould, if carefully used, will do for casting a number of plates, but if many are to be made it should be of iron. In this form of mould no machine work is necessary except a little drilling and filing. Whether the wood or the iron mould is to be used, the first step is to make it in wood, only one-half need be made for the iron one, and this is used as a pattern from which two iron castings are made.

distances of $\frac{3}{8}$ ". When strips are in place cut six notches 3-16" wide at the top, and $\frac{1}{8}$ " wide at the bottom, crosswise through all the strips down to the board. This may be done with a back-saw, finishing with a knife and a strip of fine sandpaper held on a thin, beveled strip of wood. If the iron mould is to be made, the pattern is now complete, except that it should be given two coats of black shellac. If, on the other hand, it is to be used as a mould it should *not* be shellaced, but a second one should be made and a strip of wood $\frac{1}{4}$ " thick and $\frac{3}{8}$ " wide, with the inner edge slightly beveled, fastened to the left-hand edge of one of them. Also make two blocks of $\frac{1}{4}$ " wood shaped as shown in drawing to go at the top to make the lug and the pouring-gate. These should be slightly beveled on three edges to give draft to the mould, *i.*

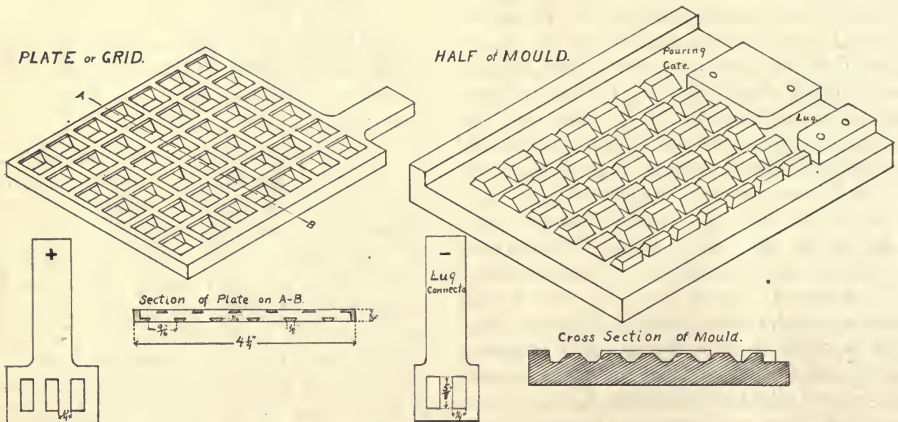

Cut out a piece of $\frac{1}{4}$ " pine board $5\frac{1}{2} \times 6\frac{1}{2}$ ". Also make seven pieces of $\frac{1}{4}$ " pine 9-16 wide on the bottom, and bevel them off on each side at 45 deg., which will make the top about $\frac{1}{2}$ " wide. These should be very accurately made, as the success of the job depends on their fitting well.

Take one of these strips and fasten it on the large board 7-16" from the long edge, using small brads and glue. It should be put 9-16" from the lower end. In like manner put on four more strips parallel with the first, using one of the strips placed bottom side up for spacing them. The sixth strip should be planed off on the outer edge to a sharper angle than the others, leaving top as it was, but making the bottom only $\frac{3}{8}$ " wide, after which it is fastened like the others.

Seven brads should be used in each strip, placing the first one 5-16" from the end, and the others at equal

e., to make the cast plate come out easily. The other half of mould should be the same, except a $\frac{3}{8}$ " strip should be placed at the bottom and no blocks at the top. When placed face to face the halves should fit together all around, making a lead-tight mould. All that remains is to carefully sandpaper off the tops of the little pyramidal blocks, but not the sides and top, to a depth of 1-16", giving space for the metal to flow. If the work has been carefully done the maker is now ready for casting.

First, *chalk* the mould all over inside rather heavily. This helps prevent burning the mould more than necessary, and also makes the lead run more freely. The wood of the mould should be as free of pitch as possible. Next melt the lead, but take great care to have it hot enough to run freely. This is important. Clamp the mould together with wooden hand screws, place

upright and pour as fast as possible without spilling. The whole secret of running lead is to get the metal in quickly, before it has a chance to freeze. After taking out the plate and re-chalking mould, you are ready for casting another. As many as twenty plates can sometimes be cast from one wooden mould.

If the iron mould is decided upon, take the wooden pattern to the foundry and have two castings made from it. Lay one casting face up on the bench, put on some coarse emery and grind the other one to a fit, using water and sliding one plate back and forth till they come together. This will take an hour or two, according to how well the pattern was made. When fitted, file off 1-16" from the face of each half, leaving the pyramids 3-16" high. If the cross notches need a little fitting, that may also be done with a thin file. The mould is then to be finished like the wooden one, by riveting iron strips on sides and top of one and side and bottom of the other.

The iron mould is to be warmed and then heavily smoked with a candle or lamp before casting. The lead should be hotter than for the wood mould, as it will run better. The positive plates will be better if a little antimony, say $\frac{1}{4}$ oz., is added to every pound of lead. When you have moulded a sufficient number of plates you are ready to paste them. Each plate will require about 6 oz. of lead oxide. Use red lead or minium, for the positives, and yellow lead, or litharge, for the negatives. The paste is a kind of mortar made by moistening the lead oxide with a ten per cent solution of sulphuric acid. To mix the acid put a sufficient quantity of water in an earthen jar and add 1-10 the quantity of acid, pouring slowly and stirring with a strip of glass. Do not pour water into acid. Mix the lead oxide to a very stiff paste with the acid water, and using a thick piece of glass or a wooden paddle for a trowel, plaster one side of the plates, working the paste well into the holes. Turn over and finish the other side in the same way. Scrape off all surplus paste and put away to dry.

To assemble the battery, cut pieces of burlap of the right size to cover the plates all over except the lug on top, and with coarse cotton cord cover plates tightly, sewing firmly around three edges. The burlap is to be folded over the fourth edge. Next take some sheet lead 1-8" or 3-16" thick and cut out two lug connectors for each cell, as shown in drawings. Next make eight strips of pine wood for each cell $\frac{1}{2} \times \frac{1}{2}$ " and $\frac{1}{4}$ " long. Lay a negative plate on the bench with the lug on the left. Put a wooden strip on each edge. Lay on a positive plate with a lug to the right, then more strips, negative plate, strips, positive plate, and so on, until you have as many as you wish. Three plates will give a capacity of 10 to 12 ampere-hours; five plates, 15 to 20; seven, 25 to 30, and so on. The voltage will be same, no matter how many or how few plates are used, namely, about $2\frac{1}{2}$ volts on open circuit and 2 volts when using normal current. The normal charge or discharge rate is 1-8 to 1-10 of the capacity: that is, the 15 ampere-hour cell should ordinarily

be charged or discharged at the rate of 2 amperes and would last about 8 hours at that rate.

When plates are grouped as above, put two or three heavy rubber bands around them and turn the bunch up on end. Fit the lug connections on with the ends pointing outward. Solder them in place, taking care not to overheat and melt the lead. Bend outer ends upward, and your battery is ready to put in the jar of acid and charge. The acid should be about one part sulphuric acid to five of water.

Do not put plates in acid after mixing till it is cool. The jar may be of hard rubber or glass. Suitable jars may be purchased, but are rather expensive. A glass jar of the right size for the five plate cell costs 50 cents. An ordinary round telegraph battery jar, costing only 25 cents, will do; or a large glass bottle may be cut off at the right height, which should be about six inches. The acid should cover the tops of the plates to depth of at least $\frac{1}{2}$ ". Evaporation of the solution may be prevented by pouring melted paraffine wax on the top of jar to a depth of $\frac{1}{4}$ ". Two or three small holes should be made in the wax to allow gas to escape when charging the battery.

The battery may be charged from any source of direct current. Alternating current will not do. About $2\frac{1}{2}$ volts per cell will be required. A small dynamo is the best thing for the purpose if power is available. Begin the charge of 15 ampere-hour cells at the rate of 4 or 5 amperes. This rate is to be reduced as the charging proceeds, ending with about half an ampere, which should be continued for six or eight hours, the first few times. The battery will not attain its full capacity till it has been charged and discharged a number of times. This process is what is called forming.

POLARITY INDICATOR.

Amateurs frequently desire to learn the polarity of their primary or secondary battery terminals. There are several contrivances constructed of glass and depending upon the coloring of the solution contained therein for a polarity indicator. A simpler method is to cut sheets of white blotting paper into small squares 2 by 2, and saturate the squares with iodine of potassium and allow them to dry. When a test is to be made, moisten a piece of the paper with water and press the battery leads down upon the wet surface about $\frac{1}{2}$ an inch apart. The positive end will turn a pronounced brown, while the negative end does not change.

A strip of glass cut one inch by four, coated with shellac and sprinkled with fine brass or other metal filings, will form a magnificent display when introduced between the balls of a secondary spark, especially at night. A pretty design or a person's name may be traced in minute sparks by this method.

A SIMPLE GALVANOMETER.

JOHN F. ATKINS.

Every amateur should possess an accurate galvanometer for general laboratory testing. While many high grade types of galvanometer are beyond the means of most electrical students, it is possible to construct an efficient instrument for a very small sum. Much of the construction can be done with tools common to every workshop, but there are certain parts which require absolute allignment, and might work more perfectly if fitted by one of experience. A friendly jeweller or machinist could render valuable assistance in half an hour's time, should the amateur be without tools for this part of the work.



First procure a cover to an ordinary, round, wood blueberry box. Cut out a circular piece of cardboard to fit inside the cover, for a dial. Wind as many turns of No. 32 cotton covered magnet wire around the outside edge as may be applied without crowding over the edge, say three layers of 12 turns per layer. Stick the wires together, and to the wood, with quick-drying shellac varnish.

Having found the exact centre of the cover, drill a small hole and insert a small piece of straight, hard, steel wire about 1-16" diameter and 1/2" long. The upper end of this rod should first be turned to a long, highly polished point. The amateur is cautioned to exercise care in fashioning this point, being sure there is no rough, feathery edge to it when completed.

Upon this point is to rest and rotate a pivot to be turned out of a piece of brass rod. The exact size and shape of the pivot is not imperative, but the shape, as shown in the illustration, should be followed quite closely.

A piece of straight ribbon steel, as long as the diameter of the cover, is next procured and cut and bent into shape as illustrated. The exact balance of the strip is next found, and a small hole punched to take the top of the pivot. Next solder the pivot and steel strip together and magnetize the steel by winding insulated wire around it and sending the current from two or three cells of battery through for a short time. Then place the needle in position upon the point and we have practically a compass, for it will be noticed that the needle points to the magnetic pole. By sending battery current through the wire coiled about the cover a deflection takes place; that is, the needle moves from north to another position and remains in that vicinity as long as the current is continued. A

couple of binding posts, to the bases of which are attached the ends of the coil and a mark or dot indicating north or zero on the dial, completes the galvanometer.

Now, as to its uses. In a simple galvanometer of this kind we find the needle susceptible to influences of any magnetic metal that may be brought near the instrument while testing. This interferes with accuracy, and care should be taken to see that this is avoided. With this instrument a comparison of current strength may be made, but its principal value is the measuring of resistance in connection with the

Wheatstone Bridge. A simple form of bridge was constructed by the writer in less than an hour's time, and a brief description, together with a sketch of it will be given in another article.

Richard Guenther, U. S. Consul-General, reports that interesting experiments are being conducted at the agricultural bacteriological station of Vienna. It is a well known fact that salts of iron are of great importance for the human system. The artificially prepared foods containing iron which are introduced into the human body have not always the desired effect because the quantities of iron contained therein, even if considerable, are not completely assimilated.

According to modern ideas, the human body may also supply its want of iron from vegetable foods, and it is expected that by increasing the quantity of iron in vegetables it will be possible to procure a natural means of supplying the human system with a nutrient rich in iron and easily assimilated. The first experiment was made with spinach, by adding hydrate of iron to the soil. The spinach grown from seed showed a percentage of iron seven times as great as ordinary spinach, without injury to the plant. This is considered a very favorable result, as the iron contents are perfectly sufficient for medicinal purposes and in a form which possesses none of the defects of the best artificial iron preparations. It is presumed that other ferruginous plants rich in iron will yield similar results, so that not only the science of medicine will be benefited but the gardeners will also find their cultivation a source of profit.

LACING LEATHER BELTS.

The ends of belts are fastened together by means of lacing, threaded through holes punched near the ends of the belts. The lacing is usually an oil-tan leather, prepared especially for the purpose, and obtainable in the various widths and lengths most suitable for the sizes of belts in common use. The following table gives the widths of lacing for different sizes of belts:

Width of Belt.	Width of lacing.
2 inches and under	$\frac{1}{2}$ inch
2 to 6 inches	5-16 "
6 to 12 "	$\frac{3}{8}$ "

The size of the holes punched for the lacing should be the smallest that will permit of lacing without great difficulty; holes having the effect of reducing the strength of the belt, and large holes failing to keep the lacing tightly in place. The usual practice is to have have $\frac{1}{2}$ inch holes in belts up to 6 inches wide and 5-16 or $\frac{3}{8}$ inch for the greater widths,

be found by measurement until experience has enabled one to do it correctly without. If the holes are not evenly spaced, upon tightening the lace, the edges will be found out of line, and in case it should be running through a shipper, a torn belt is likely to result.

Begin to lace at the centre holes, first passing the lace half through the hole *a* from the under or pulley side of the belt; then pass the other end through the hole *b*; *A*, Fig. 1, showing the back or outside of the belt, and *B* the face or pulley side. Continuing, pass down through hole *d*, up through *c*, down *d* again and up through *c*; then across to *b* and up through *h*, where a notch is cut in the lace about even with the back edge of the belt to prevent the end of the lace from slipping back through the hole. The other end of the lace is then put down through the hole *e*, then up through *f*, down *e* again and up *f*, across to *a* and up through *g*, where the end is notched as described. The holes *g* and *h* should be smaller than the other holes, the lace fitting tightly therein. It will be noted that all crossings of the lace are outside.

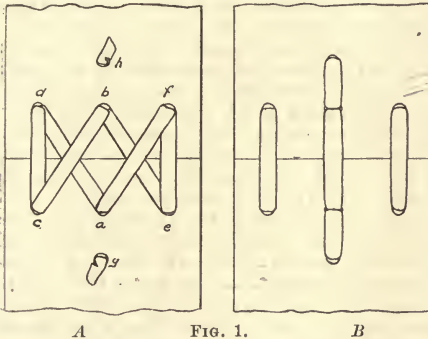

FIG. 1.

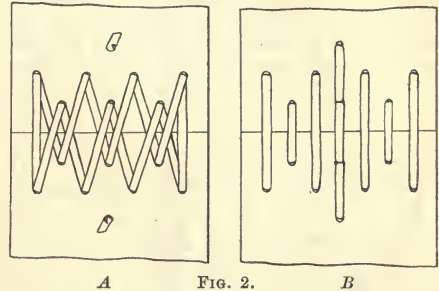

FIG. 2.

In cutting the ends of a belt preparatory to lacing, the line for the cut should be marked with a scratch point or pencil along the edge of a square and cut with a sharp knife, as it is absolutely necessary to the even running of the belt that the joint should be square and at right angles with the edges of the belt.

There are several common arrangements for lacing belts, but of the two here given the first is preferred, as in cutting off a piece for the purpose of strengthening the belt, the length cut off is not as long as with the second, the latter being likely to cause too tight a belt if both rows are cut off, and an uneven lacing if only one row is cut off. On only quite long belts can the second style of lacing be used to good advantage.

For even the narrowest widths of belt there should be at least two holes in each end, the illustrations being for a belt three inches wide. For narrow belts omit the centre holes and the lacing for one pair of holes. The holes should centre 1 inch apart and about $\frac{3}{8}$ inch from the ends of the belt, and be punched exactly opposite each other. The proper places should

The method shown in Fig. 2 is somewhat stronger than the other, and is best adapted to long belts which will allow both rows of holes to be cut off when tightening, though the belt can be laced in the same manner if only one row is cut off. The arrangement is carried out much the same as with the first method, and is shown so clearly in the illustration that further description should not be necessary. A similar arrangement, much used, places the four-hole rows nearest the ends, but that shown is to be preferred as giving more strength to the edges and, therefore, less likely to tear out should the belt catch on the shipper. The ends of the lacing are put up through the centre holes and then threaded to the holes nearest the edges, two turns being taken through these holes before starting towards the centre holes. One end is carried to a stay hole, and notched to hold it; the other carried down one centre hole and up through the other, notched and the end drawn under the nearest cross lacing, where it should hold all right.

HOW TO BUILD A SAIL-BOAT.

CARL H. CLARK.

VI. Fitting an Engine and Rigging the Sails.

The hull of the boat having been completed in proper manner for use as a sailing boat, it has been thought best, in view of the great increase in power boating, to describe the slight additional labor of fitting an engine of about $1\frac{1}{2}$ or 2 h. p. for auxiliary service. The advantages of a practical combination of the power and sail boats are too well known to need any explanation. The only difference in the boat when so fitted is the addition of the engine beds inside, and the aperture in the skeg to admit of the wheel, as shown in Fig. 1. The top of the cylinder will project above the floor and can be fitted with a removable box to protect it when not in use, and which serves as a seat when in place. It is suggested that those intending to fit power, place the centreboard box about one foot further forward to give rather more room for the engine. The box is now in the proper place for use with sails alone, but placing it a foot further forward will not affect her sailing, and the change in the slot should be made when the keel is sawed. This is only to give additional room, as the engine can be put in with the box in its present position.

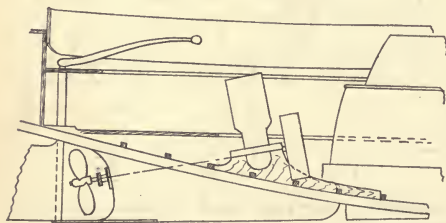

The engine should be placed as near the centre board box as possible and allow easy access to the starting handle. The centreboard logs are cut out to admit the fly wheel, which should clear on the lower side by about an inch.

The skeg is cut, as in Fig. 17, to give room for the propeller. The shaft hole is bored in the right place and with the proper slant. The beds inside are about 2" thick, fitted the proper distance apart to fit the flanges on the engine bed. Some engines require cross beds, like deep, heavy floors, which are easily fitted and fastened to the keel and plank.

A fore and aft bed is to be preferred and is shaped somewhat as in Fig. 1. The bed pieces are notched over the frames and fastened through the plank, and should run well forward. In either case the beds should have a cross brace between them to keep them upright.

Care must be used to prevent the ingress of water at the joint between the skeg and the keel. A stop water, or pine plug, should be driven in the joint about 3" on either side of the hole, and the joint between them carefully calked. The foot of the rudder, also, must be supported by the iron skeg, which is now made longer for this purpose.

The installation of the engine is described in the chapter on the power dory. The exhaust pipe should be led down alongside the engine and then under the floor to the muffler, which is placed either in the stern or inside one of the seats, as is most convenient. The outlet from the muffler is then carried out through the stern. The gasolene tank may be placed wherever is most convenient, one of about ten gallons being of sufficient capacity. The stern stuffing box, or gland, is fastened on the after side of the skeg with lug screws and must be nicely fitted not to cramp or bend the shaft when set up. The general directions for piping, as given for the power dory, apply equally well to this installation. The position of the wheel in relation to the starting handle, or some other point, should be determined, that the wheel may be placed vertically behind the skeg when under sail.

The sail plan is shown in Fig. 2; that of the jib and mainsail type, as it is the handiest for general use and the most popular rig for small boats. A yawl rig could easily be substituted if the boat is to be used for cruising. The spars are of spruce of the lengths shown in Fig. 2. The mast is 21' long, 4" in diameter at the deck, tapering to 3 $\frac{1}{2}$ " at the gaff and 3" at the top. It may be gotten out of a square stick of timber or from a small tree, such as are sold for the purpose. If worked out of a square stick it should first be tapered correctly, the corners then taken off, making it octagon, and finally rounding it off smoothly and finishing with sandpaper.

There are three eyes at the top of the mast, the upper as near the top as possible; the next about 8" below the upper, and the lower about 2' below the second; they are riveted through over a washer.

The boom is 19' 8" long, 3" in diameter at the middle, 2 $\frac{1}{2}$ " at the inner and 2" at the outer end. The inner end is fitted with a band, tightly driven on to prevent it splitting when the end of the gooseneck is driven in. The gaff is 12' 6" long, of oval section about 3 $\frac{1}{2}$ " by 1 $\frac{1}{2}$ ", tapering towards the outer end. The inner end is fitted with jaws which fit the mast. The latter are of oak and may be cut out, or better, may be bought, all bent to shape, at stores dealing in yacht supplies. They are riveted on to the sides of the gaff. There is also an eye in this end for the

throat halliard.

The bowsprit is 4' outboard, and about 6½', total length. It is 1½" thick and 5" wide at the stem and tapers toward each end. There is a mortise in it to fit over the top of the stem, and two eyes in the outer end one above and one below; these latter must be very strong, as there is much strain upon them. There are

The standing rigging is of ¼" galvanized steel wire. In each of the three stays an eye should be spliced which will just fit the top of the mast and rest upon the middle one of the three eyes, a small oak chock piece should also be screwed to the mast opposite the eye, to prevent their slipping down. At the lower end of each a thimble is spliced, the stays being left of the



two ¾" bolts in the inboard end, fastened with nuts below. To take the lower end of the bobstay a strong eye is fastened to the stem by bolting through. The spars should be smoothly sandpapered and finished with a coat of white shellac and two coats of good spar varnish.

A pair of chain plates are bolted to the hull about 12" back from the mast, to hold the side stays; the bolts, if possible, passing through a frame.

correct length that the forestay can be fastened to the eye in the top of the bowsprit with a shackle, and the two side stays into turn buckles, the lower end of which are shackled into the chain plates. This allows the rigging to be set up taut. The bobstay is a piece of ⅝" galvanized wire rope, fitted with thimbles and turnbuckles to take up the slack.

The sails are made of heavy drill, the process being the same as described for the sailing dory. It is rec-

ommended, however, that two bights be turned in each cloth before sewing, as this makes a stronger sail, which is needed for the larger size. The appearance of the narrow bight is also good.

The outline is laid out on some large floor, if possible, using the diagonal measurement to obtain the angles correctly. The mainsail should be made about 9" shorter on the hoist and gaff, and about 12" shorter on the boom than the given dimensions, to allow for stretch. The procedure will be the same as for the smaller sails, but the labor will, of course, be much greater. The amount, however, will not be excessive if a good sewing machine can be used. The jib, also, must be made a few inches smaller. They must be strongly stitched with rather coarse thread and well reinforced at the corners.

Three rows of reef points are worked into the mainsail, 3' apart, vertically. On a line 4', 6' and 9' from and parallel to the boom, an eyelet is worked on each lap or bight; a piece of small cotton rope about 14" long is passed through the eyelet half its length and held in place by a few stitches of thread, leaving one end on each side of the sail. These are brought down and tied under the bolt rope when it is desired to reef the sail. A strong thimble, or eye, is worked into each corner of the sail, and also one on the edges opposite each row of reef points. The hoist is divided into equal spaces of about a foot each and rather smaller eyes or grommets put in to fasten to the hoops. Eyes are also worked along the gaff about 8" apart. These eyes may be sewed in over a ring, or the regular brass grommets may be purchased, which will save much labor. For fastening to the boom small thimbles are sewed along the foot about 9 inches apart. The jib has an eye in each corner and eyelets about 9" apart on the edge, which goes on the stay. Snap hooks should be fastened into these eyes so that the jib may be snapped on to the stay, and a larger snap hook at the lower corner hooks into the eye on the bowsprit.

In rigging the boat the mast is set up, the required number of hoops and the gooseneck band being first slipped on, and the rigging set up taught by means of the turnbuckles.

A mainsheet traveller of about $\frac{1}{2}$ " galvanized iron is fastened across the stern to allow the main sheet to travel back and forth. A double deck block for the halliards should be fastened to the deck on each side of the mast, and cleats fastened on the top of the cabin trunk within easy reach from the standing room for fastening the halliards.

A cleat is fastened on the after end of the wash rail for the main sheet; other cleats and fittings may be put on as they appear to be needed. For blocks the ordinary galvanized iron blocks may be used. The main sheet is rigged as shown—the end looping over the boom end. The topping lift leads to a single block on the upper eye on the mast and down through the deck block. The throat halliard is rigged as shown, with two single blocks, the end leading down to a

cleat. For the peak halliard one single and one double block are required, rigged as shown: the bridle on the gaff is of $\frac{1}{4}$ " wire rope, eyes being spliced in to encircle the gaff, being prevented from slipping down by small chock pieces fastened to the sides of the gaff. The halliards and jib sheet are of 12-thread manila rope and the main sheet about $\frac{1}{2}$ " in diameter.

In bending the sails the mainsail is first laced to the gaff with a small cotton cord or marline, a hole being bored in the ends of the gaff to allow it to reeve through. It is then laced to each mast hoop in turn and lastly, to the boom. For the latter purpose a cotton line is rove through the eyes on the boom and the thimbles on the foot of the mainsail alternately and made fast at the ends. The corners of the sail are held in place with marline. The sail must not be stretched very tightly at first or it will be ruined; it must be allowed to wrinkle slightly at first until some of the stretch is taken out.

The jib sheet blocks are fastened to a snap eye; one end is fastened to an eye in the deck, the other runs through a fair leader and aft to the cleat. Note that there are two jib sheets, one on each side. If it is desired to have the jib set more smoothly a boom about 5' long may be laced to the foot.

After sailing the boat and becoming accustomed to her, various additions may be made to her outfit and rigging as may be suggested by experience. After the boat has been used half the season she should be hauled out and smoothed up and given a coat of paint and varnish. This care will amply repay the owner, as a new boat requires some attention while the several parts are setting into shape. All varnished wood should be kept well covered with varnish.

A writer in the Aluminum World gives the constituents of a hard alloy which has been found very useful for the operating levers of certain machines.

The metal now generally used for this purpose by the various typewriter companies is aluminum silver, or silver metal. The proportions are given as follows:—

Copper	57.00
Nickel	20.00
Zinc	20.00
Aluminum	3.00

This alloy when used on typewriting machines is nickle plated, for the sake of the first appearance; but so far as corrosion is concerned, nickelling is unnecessary. In regard to its other qualities, they are of a character that recommends the alloy for many purposes. It is stiff and strong and cannot be bent to any extent without breaking, especially if the percentage of aluminum is increased to 3.5 per cent; it casts free from pin holes and blow holes. The liquid metal completely fills the mould, giving sharp, clean castings, true to pattern; its cost is not greater than brass; its color is silver white, and its hardness makes it susceptible of a high polish.

“ WIRELESS ” TELEGRAPH PLANT BY AMATEUR WORK READERS

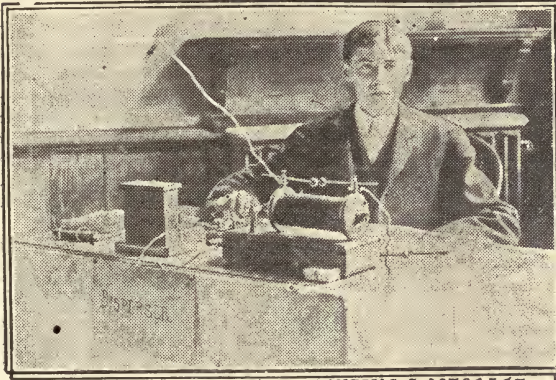

NEWELL A. THOMPSON JR. SENDING A MESSAGE.

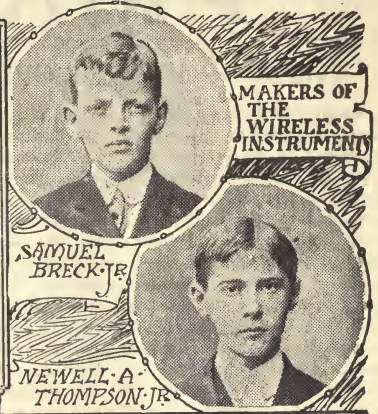

A wonderful piece of mechanism from the hands of schoolboys is that put on view recently in the Prince grammar school, Exeter and Newbury Sts. It is a wireless telegraph exhibit, and is the biggest surprise that has come to the management of Boston's schools during all the years that manual training has been a part of the system. The wireless plant is thoroughly equipped and is capable of being operated for eight miles. It is the work of Newell A. Thompson, Jr., 14 years old, of 553 Newbury st. west, and Samuel Breck, Jr., 13 years old, of 171 Bellevue st., Roxbury, both of whom are in grade 8. The boy last fall visited one of the fairs in Mechanics' Building and became interested in a wireless telegraph exhibit there. Being readers of AMATEUR WORK, and seeing the various articles on "Wireless Telegraphy" appearing in the different numbers, they determined to make an outfit themselves. In young Thompson's workshop the boys labored, and on Patriot's Day they were able to operate successfully for a distance of 256 feet. The experiments were carried further, and already they have demonstrated its practical ability by sending messages across the Charles river, which is not far from young Thompson's home. It has been found upon test that eight miles can be readily covered. Besides receiving parental advice and encouragement, both boys have been given much help by E. Bentley Young, master of the Prince school, and by the instructor in manual training, John C. Brodhead. The first receiver which the boys made was worked out under Mr. Brodhead. The apparatus was set up on the platform in the hall of the school. Visitors were greatly interested in the receiving and sending of messages.

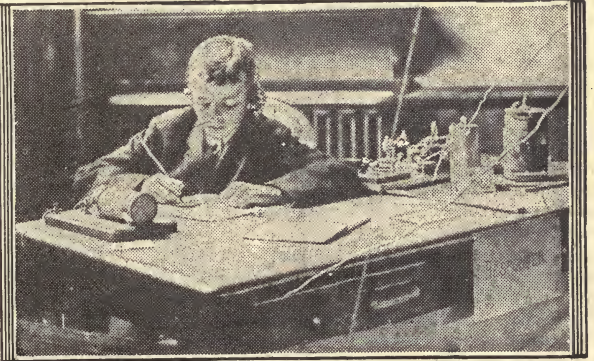

SAMUEL BRECK JR. RECEIVING THE MESSAGE.

With the exception of one or two pieces of apparatus quite beyond their powers of construction at present, the work was done entirely by the boys.

As a result of three years research, Prof. Burgess, of Wisconsin University, aided by an assistant, has, it is said, found a method of making pure iron at a cost of a cent a pound. The process is stated to be somewhat similar to that of refining copper electrically. Pure iron, on account of its electrical properties, is very valuable, and in great demand for the construction of electrical apparatus.

Paper stockings and gloves are now said to be in progress of manufacture. They are said to last as long as those made from more ordinary materials, which is not saying very much.

PHOTOGRAPHY.

THE "PYRO" DEVELOPER.

The professional, as well as the old stager in the amateur ranks, uses pyro. The novices uses one of the many newer developers. For years, writes F. J. Clute, in the St. Louis and Canadian Photographer, we have been told by the former that their reasons for giving pyro the preference was that it gave them more control. None of them have told us just why this "pliability" of the pyro developer was so universally observed by the older workers. They themselves have, in many cases, put forward the theory that it was no doubt owing to their familiarity with its working. Its poor keeping qualities and in inclination to stain the hands has been the reason most generally given by the amateur for his discarding it in favor of one of the more cleanly working developers. The real reason why the pyro developer gives an amount of control not obtainable with any other reducing agent lies in the fact that pyro possesses, as distinctive from all the other developers, the quality of working softly like metol or rodinal, when well diluted, while still retaining the power of equalling hydroquinone or glycin as a producer of hard negatives when used in a less dilute solution. This good quality is possessed by none of the other reducers; at least, only to a very limited extent, and at once explains the preference of the experienced worker for "good old pyro." Prepared intelligently, its keeping qualities in solution are all that can be reasonably desired. Any developer will deteriorate, and where the deterioration is indicated by a relative amount of discoloration, this discoloration is more of an advantage than otherwise. The staining to which pyro pleads guilty is another bugbear that the tyro has been taught to dread. If the fear of staining his fingers would only keep him from continually raising the plate from the tray to hold it in front of the ruby glass, well and good. Use pyro and leave the plate to the mercy of the solution. Learn to judge the condition of the latent image, gradually becoming visible, by the time required and the way in which it comes up as the plate lies in the tray. It is this holding the partially developed negative with its glass side close to the lamp that causes many of the poor negatives that the tyro turns out. Leave the plate in the solution, where the film of amber colored developer serves the same purpose as an extra sheet of ruby glass, and you will obtain clearer negatives. Of course, as development nears completion, an examination by transmitted light is occasionally required. Rubbing a little vaseline well into the ends of the fingers, around the roots, and underneath the ends of the nails will prevent stains. Afterwards wiping the hands well on a dry cloth will leave the vaseline where stains are most

liable to occur, while removing it from those parts of the fingers most likely to come in contact with the holders, slides, and plates. Use a two solution developer, of course. Boil the water used to dissolve the pyro to expel the air. Add a few small crystals of citric acid, that the solution may not be alkaline; use a good quality of sulphite, and keep well corked. For the alkali solution, less precautions are required. Use common washing soda, and filter the solution.

You can dry a negative very quickly within five minutes by taking advantage of the property of methylated spirit to displace the water within the pores of the gelatine. Once the water is removed the spirit volatilises quite readily in the air, leaving the negative dry within a few minutes; but to succeed with the method it is most necessary that the water should be thoroughly removed, and this will not be the case unless it is placed in a bath of strong spirit. If a number of negatives are being handled, the water extracted from each soon weakens the spirit, and that is why the following procedure should be adopted:—Take three batches of spirit, and place the negative in Nos. 1, 2, and 3 in turn each for five minutes, filling bath No. 1 with a fresh negative as soon as the first is in No. 2, and so, keeping the three dishes occupied. As soon as the negative comes from the third bath it will dry almost instantly on being waved in the air. Though not necessary, it is a good plan to mop off as much surface moisture as possible, before putting the negative in the spirit, with a soft cambric pocket handkerchief. In the course of time, all the spirit baths naturally become weakened by the absorption of water. Then they should be collected in a big bottle and dry potassium carbonate, in fair quantity, be added, and shaken occasionally. The water will be absorbed by the barbonate, and will collect at the bottom of the bottle as a heavy liquid. The renewed spirit can then be poured off.

Negatives are labelled by but few photographers with even a fair amount of success. And yet the work is easy, as the following, from the *Photographic News* will show. Dissolve some maroon aniline in powder, in methylated spirit, so as to make a very strong solution. In some places the solution can be bought ready made and is used for coloring dresses, etc. Add to it an equal bulk of water, and a little gum solution or glycerine, to keep it from running too quickly off the pen, and then write with this ink on the film, using a fine pen. It will give clear, sharp, and well defined letters. On glass negative it must be written the reverse way, and this is said to be easy after a little practice. With celluloid films coated with gelatine on the back, write on this back in the proper way.

JUNIOR DEPARTMENT

For the Instruction and Information of Younger Readers.

ELEMENTARY MECHANICS.

J. A. COOLIDGE.

V. The Pulley.

The pulley is a wheel with a groove in its rim set in a frame or "sheaf". The wheel must turn freely upon its axis and carry a rope in the groove of its rim. If the frame of the pulley be stationary the name "fixed pulley" is given it, and its value consists in enabling a force to act in some other direction than the direction we wish the weight to move.

fixed pulley is a change in direction of the force, or lies in the ability to use the force of animals.

If two or more wheels are set in the same frame they make, with the rope used, what is called a block and tackle. In a system of pulleys, one pulley must be fixed and another be movable. We will now make a pair of pulleys, each having two wheels, and learn from the experiments we may perform, the laws governing their use and the advantages gained by using them. To one able and willing to buy some metal pulleys, directions for making them may be omitted. I have purposely made these of wood because, to most of the readers of these articles, I feel that the matter

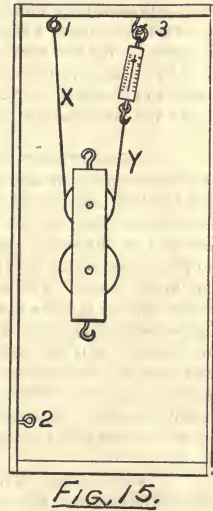
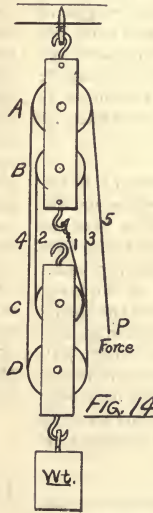
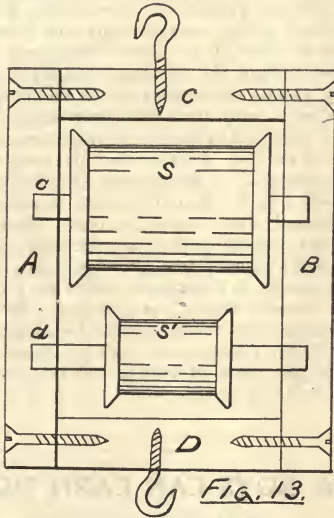

Who has not seen bales of hay lifted, one by one, into a stable door in the second story? A man stands on the ground and pulls down on a rope that passes over a pulley above the barn door. The force pulls down, the weight rises. Better still, sometimes the rope passes through a second pulley and a horse is attached to the end of the rope. As the horse moves in a horizontal direction, one part of the rope is going down, the other part with the hay is rising until it stops opposite the open door, and a man standing in the doorway swings the hay into the stable. The pulley of this kind is like a lever having equal arms. The force must be equal to the weight lifted and enough more to overcome the friction. The advantage of the

of expense is one of the foremost considerations, and with the materials needed for these pulleys the expense will be very slight.

Take a small piece of half-inch stock, cherry, maple, or other hard wood, preferred, cut two strips, *AB*, Fig. 13, 4" long, $\frac{1}{2}$ " wide, and two others, *CD*, $2\frac{1}{2}$ " x $\frac{1}{4}$ " in each of the long strips bore two holes, *c* and *d* 5-16" in diameter and $\frac{1}{4}$ " deep. Make *c* centre $1\frac{1}{8}$ " from the upper end, and *d* $1\frac{1}{8}$ " from the lower end. Take two brass rods $\frac{1}{4}$ " diameter and $2\frac{1}{2}$ " long, on one place a spool *S*, 2" long and $1\frac{1}{4}$ " smallest diameter; on the other place a smaller spool, *S'*, $1\frac{1}{4}$ " long and $\frac{3}{8}$ " in diameter. These may be fastened to the rods with glue, but should be made very smooth. The rods should be

fitted into the holes *c*, *d*, and should turn in these holes with very little friction. A little powdered graphite helps them turn readily. The frame may now be fastened at the corners by inch screws, or $1\frac{1}{2}$ " wire nails. A little glue in each joint will make the frame more substantial. At each end of the frame a screw hook should be inserted, as in Fig. 13.

Our pulleys are now ready for use. They differ from those in everyday use in not having the wheels side by side, but are quite like some that are sold for experimental purposes. Should any prefer wheels of the same size, two spools can be used of the same size as *S* by making *AB* $4\frac{1}{2}$ " long and making *d* centre $1\frac{1}{2}$ " from the lower end. A box $2\frac{1}{2}$ ' or 3' long, without top and bottom will give us a cheap frame in which to use our pulleys.

EXPERIMENT IX.

With our spring balance, first weigh the pulley. Take a short flexible linen cord, fasten one end to a screw eye in the upper part of the box and the other to the spring balance, as in Fig. 15. Notice that the reading in the balance indicates only one-half the weight of the pulley. Hang a 16-ounce weight on the hook below and read again. We find that one-half the entire weight is held by string *X*, the other half by string *Y*. This is the secret of the pulley. The weight lifted is supported by two or more strings, each one bearing its part.

EXPERIMENT X.

Fasten one upper pulley to screw eye No. 1 in the upper part of the box, and the other to screw eye No. 2 in the lower part. See Fig. 15. Hang a 16-ounce weight on one end of the string, pass the string over one wheel of the upper pulley and through the small wheel of the lower pulley. The weight of the lower pulley will rest on the large wheel. Use the spring balance to measure the horizontal force which, applied to the end of the cord, will lift the weight. Both pulleys are fixed and the force used is more than the weight lifted, because of the friction. The only gain is the change in direction. If some very large weight were to be lifted a horse could be used in such an arrangement.

EXPERIMENT XI.

Arrange the pulleys as in Fig. 14. One end of the cord is attached to the lower hook of the fixed pulley, and, after passing over all the wheels, ends at *P*, where the power is exerted. A 32-ounce weight is hung from the lower hook of the fixed pulley, and an 8-ounce weight at the end, *P*. The weight is balanced by one one-fourth as large, because the four cords, 1, 2, 3, 4, are each holding one-fourth, and cord 5 is pulling against cord 4. The ratio of gain is 1 : 4. In place of the weight, *P*, use a spring balance and pull until the weight rises. Read the balance carefully and then allow the weight to descend, using just enough force on the balance to make its motion regular. Read the balance again. The difference between these readings shows how much friction must be overcome. This is, of course, considerable, and yet

the gain in such a contrivance is apparent. Try two other weights and record carefully the results. Let us get the principle firmly fixed in our minds that, after deducting the friction, the weight lifted divided by the number of strings attached to the movable pulley must equal the power.

Where is the loss? Every machine shows a loss as well as a gain. Repeat experiment XI, measuring the distance that the weight rises while the power is moving over a distance of one foot. We shall find it three inches. To move a weight one foot will require the power to pass through a distance of four feet.

EXPERIMENT XII.

Fasten the string to the upper hook of the lower pulley, pass it through the grooves of the four wheels, and then fasten the end to our spring balance. Hang the upper pulley on screw eye No. 1, and the balance on screw eye No. 2. We now have five strings attached to the movable pulley. Hang weights amounting to 10 oz., 15 oz., 20 oz. and 25 oz., on the hook of the lower pulley. Compare the readings of the balance in these cases with the weights. Do they not run 2, 3, 4, 5, respectively? Other arrangements are possible and should be tried. Call to mind where you have seen pulleys used and the advantage gained by their use. Seldom a house moved but that the gain in power, increased as it is by using the crank and axle, is still further magnified by having the ropes pass through a system of pulleys. A pulley also plays an important part in derricks. In lifting large gas pipes and water pipes and lowering them into their trenches, pulleys are frequently used. Lastly, on board ship their uses are many. Single pulleys are so frequent that we need mention but a few. Windows open and shut easily because it is balanced by weights that hang on the opposite sides of two pulleys. The cages in elevators are balanced by weights hanging on a cable or cord that passes over a pulley. These instances show us the value of pulleys and the many uses to which they may be put.

HOW BOYS CAN EARN MONEY.

III. Making Jardiniere Stands.

RALPH LAWRENCE BUGBEE.

One of the easiest ways for a boy with a capital of \$5 to earn money is by making small jardiniere stands and selling them to neighbors and friends. These stands are made of whitewood, oak, or other suitable wood, are octagonal in shape and have four curved legs. They are about 18" high, and are very pretty when carefully made and finished with light oak or ebony oil stain. The tools and materials should not cost more than \$3.50. A saw, plane, half-inch chisel, half round file and sandpaper will be necessary, also stains, shellac, varnish and brushes.

The top is cut from $\frac{3}{4}$ " stock, $12\frac{1}{2}$ " wide, in the form of an octagon $14\frac{1}{2}$ " diameter; the upper edges should be bevelled at an angle of 45 deg. down to lines drawn $\frac{1}{2}$ " from the upper edges.

The four legs are made from $\frac{3}{4}$ " stock and $12\frac{1}{2}$ " wide. A board 7' long will make twelve legs of the shape shown in Fig. 2. They can be sawed out at home on a jig saw, but had better be sawed out by a band saw at some wood-working shop, if possible, where the stock is purchased. On two of the legs the space between A and B should be $5\frac{1}{2}$ ", but on the other two, $5\frac{3}{4}$ ".

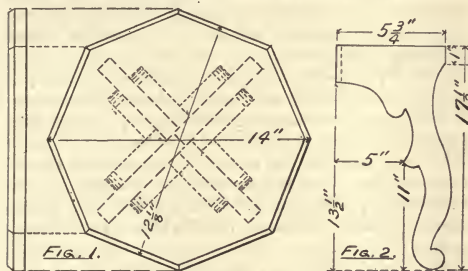

After carefully smoothing the top with sandpaper, and the legs with a half round file and sandpaper, cut eight small blocks $\frac{3}{4}$ " square, four of which should be 3", and the other 3 $\frac{3}{4}$ " long, the outer ends being cut to a half round.

To put the stand together, take the two legs, the tops of which measure $5\frac{3}{4}$ " and glue the two inner sides together; then take the other two legs and glue them on opposite sides of the joint, as in Fig. 1. The outer edges of the legs should come $1\frac{1}{2}$ " from the edges of the top. The short blocks are then glued to the legs and top, as shown in Fig. 1.

The way to stain and finish has been fully described by Mr. Putnam in the Nov., 1902, number of AMATEUR WORK, so is not given. The stands are sold at prices varying from 75 cents to \$1.50, according to wood and finish.

VARNISH MAKING.

The resins used in making oleo-resinous varnish are of vegetable origin, and some are said to be collected from the trunks of living trees; but by far the most of them are found in the earth, the trees which produce them having died, fallen, and decayed, and the lumps of resin having become gradually buried in the soil; where they have remained for hundreds or, perhaps, thousands of years. In some cases, these lumps are found to contain insects, which were buried in them when they had the consistency of a soft balsam; and their antiquity is shown not only by hardening of the resin, but also by the fact that the insects, of which hundreds of sorts have been found, belong to species

now extinct. These resins, which are found in tropical and sub-tropical regions, are collected by the natives and sold to the traders, who sort and clean them before shipment. The price of standard kinds have doubled in the last fifteen years, the supply falling to keep pace with the increasing demand.

The apparatus of the varnish-maker is simple. It consists of a cylindrical, flat-bottomed copper kettle, 3' in diameter and 3' deep, loosely mounted on a low, four-wheeled truck which may be drawn about by the workman. The kettle is provided with a loose cover in which holes are made to receive the stirring-rod and to facilitate the escape of gases. The stirring-rod is a slender steel rod with a wooden handle, about 5' long. The thermometers used in regulating the temperature of the kettle's contents are about 3' long, protected by well-made brass cases.

In the kettle the operator first puts the resin, 100 lb. being the standard charge, though 125 lb. is more frequently used. The kettle is then wheeled over a hot coke fire which is built in a fire-pit, under, or adjacent to, a chimney with a flue of from 10 to 25 sq. ft. cross section. This chimney creates a draught of great volume, necessary not so much to carry off the products of combustion, for very little fuel is used, as to remove the vapors generated in melting the resin, which are very acid and irritating, as well as highly inflammable. The kettle is kept over the fire about half an hour, or until the resin is all melted, which the varnish maker knows by feeling the liquid to be smooth as he stirs it, and by looking at drops of it which he withdraws on the stirring-rod. The temperature rises to about 600° or 700° F.

When all is melted, the kettle is drawn from the fire, the cover lifted off, and a quantity of hot linned oil is gradually added. If it is desired to make a hard and brilliant varnish, the amount of oil may not be more than 8 gal. or 10 gal. to the 100 lb. of resin weighed before melting; but if it must have more elasticity, more oil is used, and for a varnish to be exposed to the weather, as on the outside of a carriage or a yacht, as much as 25 or 30 gallons is employed.

When the oil is all in, the kettle is put back on the fire and the mixture is cooked until its components have thoroughly united. If this operation is not sufficiently carried out, the resulting varnish will lack some of the durability that it should normally possess; if carried too far, the product will be too thick, and will require thinning with spirits of turpentine to an excessive degree, causing too thin a final film.

When properly cooked, the kettle is removed from the fire, and when it has cooled down to about 300° F. enough spirit of turpentine is added to make the varnish, when cold, of the proper consistency to flow out under the brush. The amount of cooking, the range of temperatures, and the quantity of turpentine needed are all empirically determined for each kind of varnish. It is then kept in tanks for several months, when it is found to be clear and ready for use.

TRADE NOTES.

There seems to be a growing demand for an accurate and reliable bench lathe that can be bought at a moderate price and at the same time is a complete screw-cutting, engine, bench lathe, suitable for laboratory, electrical, optical and experimental work, tool, model, scientific instrument making, etc.; in short, for profitable use in all lines of fine, accurate manufacturing and precision service. The "star Special" screw-cutting bench lathe, here illustrated, has been built to supply this demand. The manufacturers claim that much of the work that is now being done on large and expensive tools can more profitably be done on this lathe.

The head-stock has a large, hollow spindle, made from a crucible steel forging, with draw-in chuck for split-collete up to $\frac{1}{4}$ -inch capacity, phosphor-bronze boxes with improved end-thrust ball-bearings; the cone pulley has three stops for wide belt, and with strong back gears gives six changes of speed; a push-pin on the head-gear allows the cone to be instantly locked or unlocked without using a wrench. The tail-stock is the curved or cut-under pattern, which allows the compound rest to swing around parallel with the ways and over base of tail-stock, with room to operate feed-screw handle; the spindle has an improved locking device and the tail-stock is provided with side adjusting screws for turning tapers, has a long bearing on the bed, and is locked in such a manner as to render it firm and rigid.

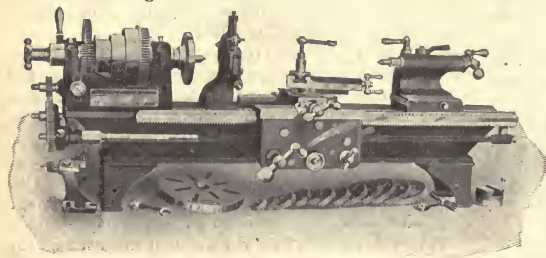

The carriage has long bearing on the ways, is gibbed to bed both front and rear. A cam locking device locks carriages to bed when using cross-feed. The cross-feed screw has a graduated collar which reads in thousandths of an inch and can be set at zero in any position. Plain and compound rests are regularly furnished and easily interchange. The base is graduated 180 degrees and renders the compound rest capable of fine adjustment. The tool-post has patented collar and shoe, which exclude all dirt and chips and admit of quick, easy and secure adjustment of the tool. If desired, can furnish the European tool-post in place of the regular American tool-post, without extra charge.

The automatic cross and longitudinal feeds are actuated by a phosphor-bronze worm on the lead-screw, receiving its power from the head spindle through spur

gears, the lead-screw is splined and simply acts as a feed rod, therefore the only wear on the threads is in screw-cutting. The automatic feeds are almost indispensable for a large variety of work, as they secure more accurate and smoother surfaces. The range of feeds is very large. The range for screw-cutting is extra large, cutting all standard threads, right or left (including $11\frac{1}{2}''$ and $27''$) from 3 to 64 without compounding the gears and nearly all threads by compounding. When desired to cut both standard and metric threads there can be furnished, for a slight advance in price, transposing gears and index for cutting International Standard Metric threads from 0.5 mm to 8 mm. The lead-screw is cut from a master screw by a new process from 30 per cent carbon steel, making an accurate, durable and most desirable lead-screw. When desired to cut metric threads only, a metric lead-screw and index is furnished in place of the regular lead-screw and index at same price. Patented spring-nuts are used in connection with split washers to hold the change gears in place. They are easy and convenient to operate and allow quick shifts of the change gears.

The bed is 46'' long, broad, deep, thoroughly well braced and accurately proportioned throughout. The rated swing is 9'' but has an actual swing of $10\frac{1}{4}''$ over bed, and 24'' between centres. The countershaft (patented) has friction clutch pulleys, easy to operate, strong and durable, also has self-aligning and self-oiling shaft bearings. The pulleys and friction bands are provided with self-closing oil cups.

Each lathe is furnished with large and small face plates, center rest, follower rest, two hardened and ground point centers, a full set of change gears and wrenches.

Extra attachments are: Taper attachment, milling and gear-cutting attachment, and blocking can be furnished when desired. While these lathes are designed for working metals, with the addition of a hand rest, screw-chuck, cup and spur centres, are suitable for wood turning.

The "Star Special" lathe is made by the Seneca Falls Manufacturing Co., 103 Water Street, Seneca Falls, N. Y., U. S. A., makers of the well known line of foot and power "Star" lathes. They will be pleased to send full description on request.

The 1904 catalogue of the S. W. Card Mfg. Co., Mansfield, Mass. presents in attractive form the various lines of taps and dies manufactured by this well known company. Those needing anything in this line should send for this catalogue.

Catalogue No. 11 of the H. H. Mayhew Co. Shelburne Falls, Mass. shows a full line of screw drivers, bit braces, glass cutters, drills gimlet bits, countersinks, nail sets, etc. Teachers of wood-working in manual training schools will find in it much of interest.

AMATEUR WORK

A MONTHLY MAGAZINE OF THE USEFUL ARTS AND SCIENCES

Vol. III. No. 9.

BOSTON, JULY, 1904.

One Dollar a Year.

A CHAMBER SET.

JOHN F. ADAMS.

The Bureau.

The general dimensions for the bureau are: Size of mirror, 42x30"; top board over drawers, 50x22". Other sizes can be worked out by anyone desiring, the general proportions being retained. The stock required is as follows:

2 pieces	36" long	2½x1¼"	
2 "	64 " "	2½x1¼"	
2 "	30 " "	17½" wide	¾" thick
4 "	45 " "	3 " "	¾" "
2 "	45 " "	2 " "	¾" "
2 "	33 " "	2 " "	¾" "
1 "	50 " "	22 " "	¾" "
2 "	43 " "	9½" "	¾" "
2 "	21½" "	6 " "	¾" "

30 feet of ¾" white wood strips 2½" wide, and white board for sides and bottoms of drawers, etc.

The first operation is to cut mortices in the front posts to receive the ends of the cross piece under the lower drawer. This cross-piece is 45" long, 3" wide and ¾" thick, allowing 1" on each end for tenons, which are 3x½". The posts are 36" long, 2½" wide and 1¾" thick, the mortices being cut with lower edge 6" from the end. The rear posts are 64" long, 2½" wide and 1¾" thick. Mortices are cut in these posts for the cross piece under the mirror frame, which is 45" long, 3" wide and ¾" thick, the mortices being 3x1x½", and the lower edges 36½" from the end of the posts.

The end pieces 30" long, 17½" wide and ¾" thick, are then glued to the posts after marking out and boring six ⅜" holes into each edge to a depth of about 4" and corresponding holes in the posts into which dowel pins are glued. The edges of the end boards are well coated with glue

and the ends are then set up in clamps until thoroughly dry. The outer surface of the end board is set in ⅜" from the posts.

While the ends are drying the drawer runs are made from strips of whitewood 2½" wide with the exception of the front sides of the runs under the top and middle drawers, which are of the same wood as the bureau, and the one under the lower drawer which has the cross piece for the outer edge and a piece of white wood just back of and glued to it. The frame under the upper drawers also has a cross piece in the centre which is morticed in. The corners of these frames are cut out to fit the posts. When completed they are screwed to the ends after the cross piece under the lower drawer and mirror have been put in place. Cabinet-makers' clamps must be used while the glue is setting. The frame under the top drawer is placed 7" from the top ends of front posts, that under the middle drawer 9½" below the first, and the lower frame is flush on the upper side with the top of the cross piece. An additional frame is then made of ¾" strips or of solid stock 48" long and 21" wide and attached firmly with wood screws to the top of the front posts and end boards. The top, 50" long, 22" wide and ¾" thick, is then put on, glue and screws from the under side being used freely to secure ample strength. A suitable moulding is run around the under edge, covering the edges of the under frame. The frame for the mirror is made of ¾" stock 2" wide, the longer pieces being 44½" long and the side pieces 33" long. The corner joints

are mitred on front side, and mortised and tenoned also. The inner back edge is rabbeted $\frac{1}{2} \times \frac{3}{8}$ " to receive the mirror, picture backing being used

The back of the bureau is sheathed with $\frac{1}{2}$ " matched sheathing, the inner edges of the drawer runs being placed to allow for this.

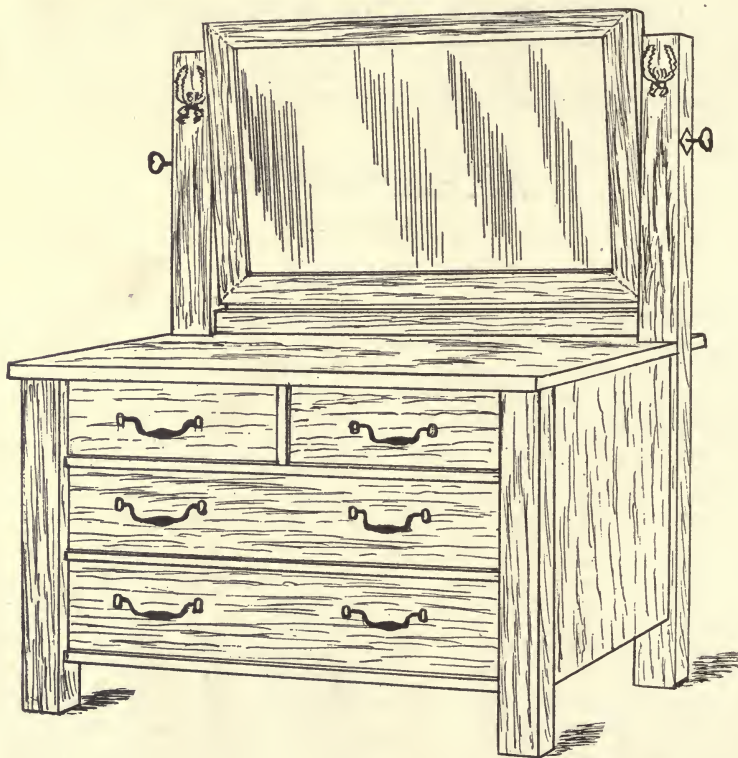

to protect back from breakage. Swivel hangers for holding the mirror are to be purchased of hardware dealers and, are placed slightly above the centre line and so that the lower edge of the mirror will clear the cross piece by about $\frac{1}{4}$ ".

The drawers are made with halved joints, though dovetailed ones would be better and stronger, but take longer to make. A division piece between the two upper drawers is put in before putting on the top. By examining the drawers in any bureau the method for making them can be easily learned, so is not here given. The drawer pulls should be of cast brass; castors are also fitted to the bottom of the posts.

There is at Durango, Mexico, a great mass of iron ore which has figured in story and fable for 300 years, and was thought to be a meteorite by Humboldt, who, however, did not quite reach Durango in his explorations. Mr. Le Roy, the United States consul at Durango, now reports that the mass proves to be a remarkable dyke emerging from a rocky plain at the elevation of 6,300 ft., rising from 400 ft. to 650 ft. in itself, and forming a mass of iron ore a mile long and one-third of a mile wide. It has been calculated that it contains 500 to 600 million gross tons above the surface, while there are no means of knowing what may be below. The ore is a hard specular hematite, with, on an average, 60 per cent of metallic iron, much of it going up even to 67 per cent.

Renew your subscription promptly.

PATTERN MAKING FOR AMATEURS.

F. W. PUTNAM.

V. Plain Cored Cylinders—Small Gland.

In the last chapter I explained the difference between green sand and baked sand cores, and the use of core boxes and core prints. In practice, usually, no regular hole less than 1" in diameter should be cored.

The size and shape of holes govern, to a large extent, the construction of patterns. Fig. 29 shows the casting of a small gland. This is a very simple pattern, yet there are at least six different methods of making the pattern, any one of

2. Patterns where the holes are not longer than four times its diameter may be constructed so as to place the core in a vertical position.

3. Patterns where the hole is longer than four times its diameter, should generally be constructed as a "split" pattern and the core placed in a horizontal position.

PLAIN CORED CYLINDERS.

Fig. 22 shows the pattern and core box for a plain cylinder 2" long and 1 1/2" diameter cored out for a 3/4" hole. We will assume that this casting is to finish up for a sleeve requiring an absolutely parallel hole. This cored hole then must be bored out parallel, and this can be much more readily done if the hole is cast parallel, because there will be less metal cut out. With

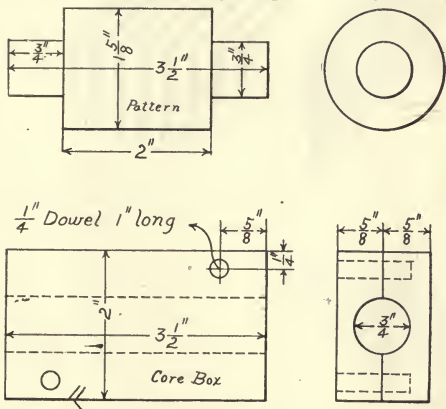

FIG. 22. PATTERN AND CORE BOX FOR CYLINDER

which might be followed. In all cases where the length of the casting nearly equals, or even exceeds, four times the diameter of the hole to be cored out, it has been found advisable to mold the pattern in a horizontal position, thus making use of a horizontal core. Even in short patterns when the diameter of the hole approaches that of the external diameter, this method is often found to be of great use, since it is difficult for the molder to tell when his core is accurately in place.

The following rules are used in the best pattern and foundry practice and should be constantly kept in mind:

1. A hole no deeper than its diameter should be formed by a green sand core.

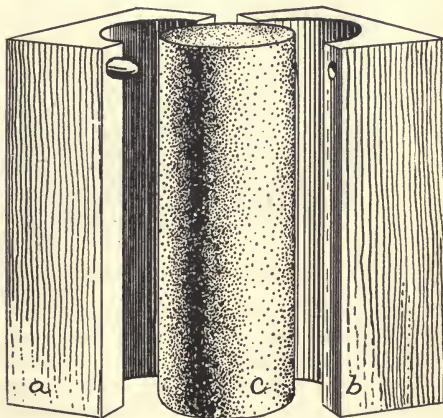

FIG. 23. CORE AND CORE BOX.

these considerations in mind we will decide to use a horizontal core with this pattern.

The kind of pattern to be made for this cylinder will depend principally on the number of castings required and the facilities at hand. When only a few castings are wanted a pattern will be turned out of one piece of stock, and having the same shape as the casting, core prints be added at

each end to leave recesses in the mold to receive the ends of the core. A pattern turned in this way greatly simplifies the work of the pattern maker, but throws additional labor on the molder, who must mold the pattern in one of three ways. The first method is shown in Fig. 27, the molder being forced to cut down the parting line of the mold. The pattern is shown at *a*, and it will be seen that the molder has cut away the sand along the lines *bc* and *de* so as to enable him to draw the pattern from the mold. This leaves the lower half of the mold simple enough, but the cope will have a heavy body of sand hanging from it, as shown at *f*. This generally is an objectionable feature and should be avoided if possible.

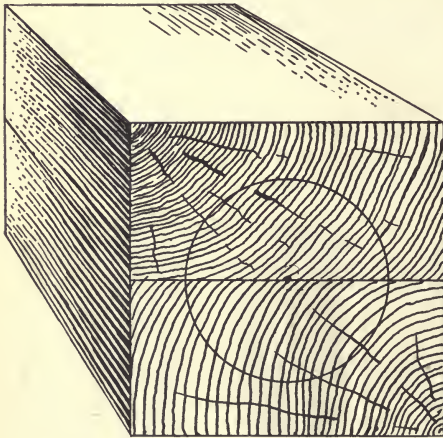

FIG. 24. LAYING OUT CORE BOX.

The second method is shown in Fig. 28. The parting line is all right, the main objection being that a hole the exact shape of the pattern cut deep enough to hold exactly half of the pattern, must first be cut in the base board or bottom board. This involves considerable labor, and the pattern is very liable to stick to the base board when it is lifted from the nowel, and making it necessary to patch up the mold formed in the nowel by the pattern.

Third method:—If a large number of castings are wanted, the pattern maker may use the solid pattern by making what is called an *odd side* or *match*. In this case the pattern is first embedded half of its depth in plaster or oil sand. The odd

side is made in a box, which must be of the same size as the flask to be used for molding. If this is made of plaster it is allowed to harden, and if made of oil sand, it is dried until the material has become very firm. The plaster or sand is usually made to adhere to the box by means of nails driven on the inside of the box. When this *odd side* or *match* is ready for use, the pattern is laid in place in the *match* and the nowel placed over it. Sand is then rammed in, after which the whole is turned over, the odd side removed, and the molding proceeds as usual.

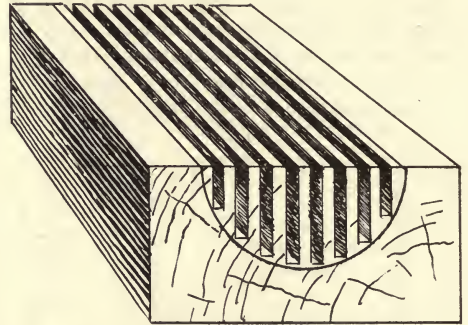

FIG. 25. SAWING OUT CORE BOX.

When there are only a small number of castings required, a *jointed* or *split* pattern is generally used, since it greatly decreases the time required for molding the pattern. A split pattern for a recessed cylinder will be given in a later article.

Fig. 22 shows the solid form of pattern requiring a piece of clean, dry pine $4\frac{1}{2}$ " long and $1\frac{1}{3}$ " square. The pattern presents no difficulty in turning, the allowance for draft being made with a $\frac{1}{4}$ " skew chisel; be sure to give a little draft to the core print ends. The main body of the pattern is to be finished with black shellac and the core prints with orange shellac. The required number of coats of black shellac should be given to the pattern, and the core prints carefully cleaned free from black shellac before any orange shellac is applied.

The core box for this pattern is shown in Fig. 22 and Fig. 23. When small round cores are to be made, a core box of form *a-b*, Fig. 23, is used, *c* representing the core. To make such a core box, two pieces of stock are used, a little longer

than the required length of core and of such size as to leave sufficient stock for strength, after the the core has been cut out.

We will require for one core box two pieces of clear dry pine $3\frac{1}{4}$ " long and large enough to allow for planing on all sides to 2" wide and $\frac{5}{8}$ " thickness. The two pieces are to be held together

deep. Wood dowels can be bought cut usually in lengths of three feet, and are made of maple, hickory, ash and oak. These pins may be prepared by the amateur if a hardened plate of steel bored with holes of the various sizes of dowel pins required can be procured. The wood for the pins having been planed up for the required size, is



FIG. 26. PATTERNMAKERS GAUGE.

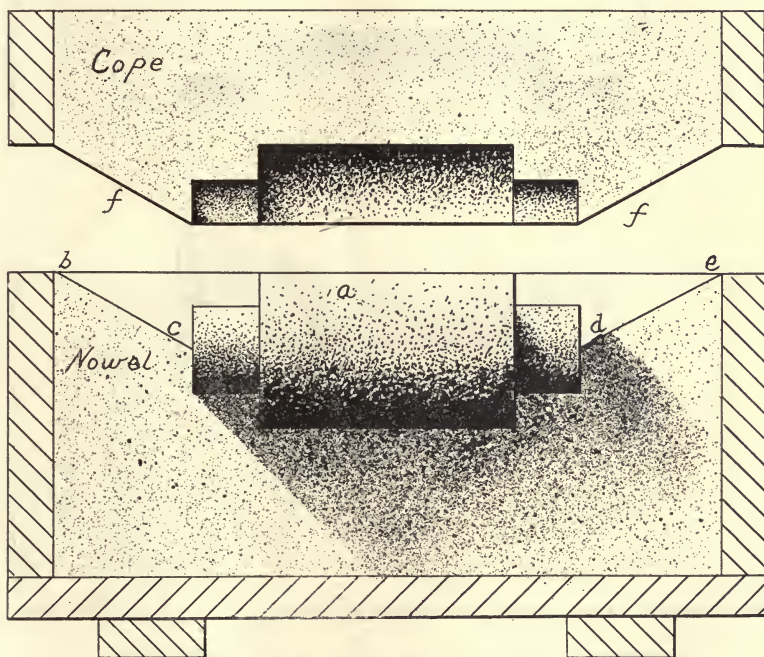

FIG. 27. METHOD OF MOLDING CYLINDER.

by two dowel pins 1" long and $\frac{1}{4}$ " in diameter, holes being bored through the top piece and $\frac{1}{16}$ " into the bottom piece. The centers for the dowel holes are shown in Fig. 22. Having carefully marked the centres for these holes in the top surface of one of these blocks, clamp the two blocks evenly together, either with wood clamps or a vise, and bore the holes absolutely straight, using a depth gauge on the bit to prevent boring too

driven with a mallet through the plate. This saves a great deal of time and makes the pins much more nearly round than is possible by hand work. Two dowels are cut off each 1" long and glued into the top piece. The projecting end is tapered off so that the two halves of the core box will fit loosely. Having the two halves of the core box dowelled, clamp them together and mark a circle on each end equal to that of the re-

quired core, $\frac{3}{4}$ " care being taken to locate the centres at equal distances from the joint sides, and to have the centre on the line of division between the two pieces, as shown in Fig. 24, *c* indicating the centre of the required circle.

Next take the two blocks apart and draw lines across the face of each piece, joining the ends of the half circles. The greater portions of the stock between these lines can be removed by

bent, being made in all sweeps (curves) and widths.

The core box should be tested with the end of a scale or steel try square to make sure that each half is exactly a half circle. This method of testing depends upon the following well known principle:—Every triangle inscribed in a semi-circle, having the diameter of the circle as one side (this side being the hypotenuse) will have a

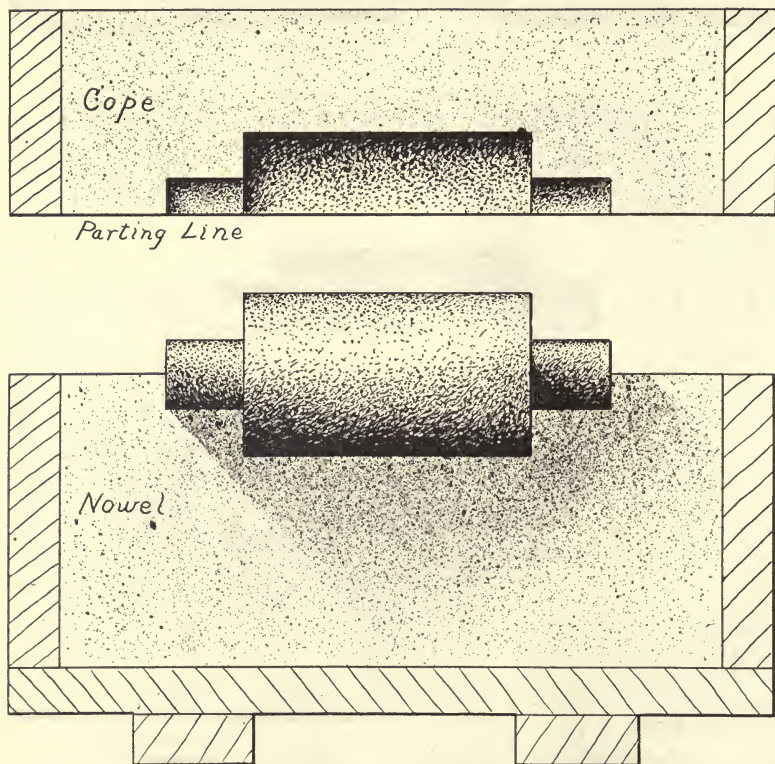

FIG. 28. ANOTHER METHOD OF MOLDING CYLINDER

means of a back saw, a series of parallel cuts being taken to approximate the half circle shown in Fig. 24. The remainder of the stock, allowing sufficient for sandpapering, is to be removed with the paring gouge or pattern maker's gouge, one of which is shown in Fig. 26. This gouge is bevelled on the inside. Some pattern maker's gouges are straight in the shank and others are

right angle formed opposite this side, by the meeting of the other two sides of the triangle. The point which is the vertex of this right angle must continually touch the curved outline of the hole in every point as the scale is moved around. Turn a cylinder $\frac{1}{8}$ " in diameter, and with sandpaper wrapped closely around it, sandpaper the two halves.

It will be remembered that I suggested making the core box $\frac{1}{4}$ " longer than the total length of pattern. This was done with our first core box in order that any breaking out of the curved surface at the ends of the box due to a cross grain or cutting outside of the lines at the ends might be removed. Of course in trimming up the ends of

article. The outside of the core box is to be finished in black shellac, and the hole with orange shellac.

SMALL GLAND.

At the commencement of this present article I stated that the small gland, the casting of which is shown in Fig. 30, might be made in at least six

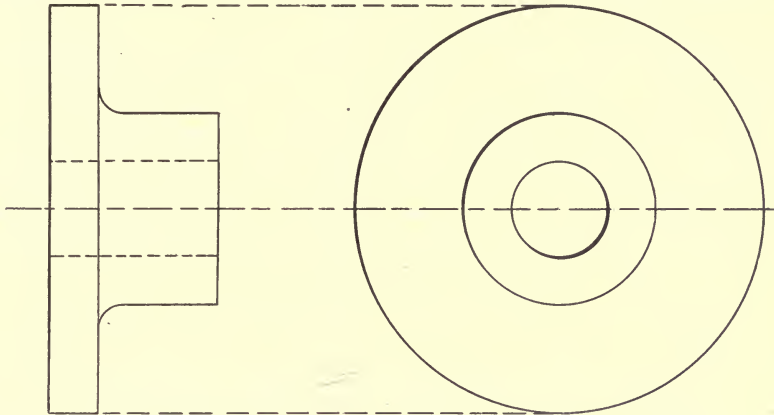

FIG. 29. PATTERN FOR SMALL GLAND WITH GREEN SAND CORE.

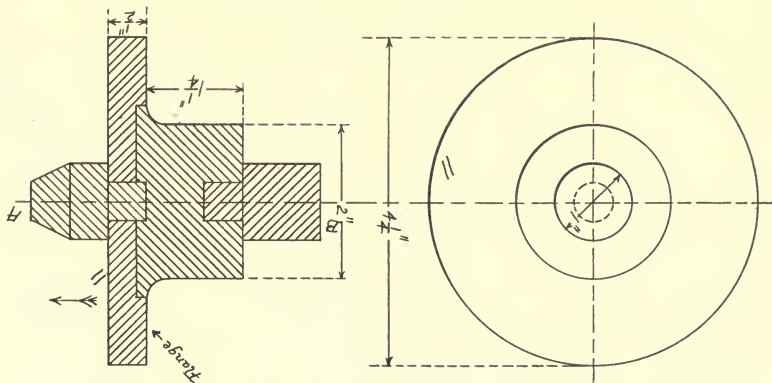

FIG. 30. PATTERN FOR SMALL GLAND WITH BAKED SAND CORE.

the core box generally; a cylinder of just the size of the hole should be inserted in order that the wood may not break out. After a little practice with the gouge, however, no difficulty should be met with in finishing up parts of the core boxes that are squared off exactly the right length.

Holes for core boxes are sometimes bored out with a bit or drill; this will be discussed in a later

different ways. I give below six different methods for making this pattern and give, very briefly, the advantages and disadvantages of each method.

1st method. Turn the pattern from a solid block, turning out or boring a hole tapered for draft, which, when the pattern is molded, will have a vertical green sand core. This is the simplest method, both as regards making and mold-

ing the pattern, since no baked sand core is required and the green sand is certain to be in the middle of the casting, which it rarely is where a baked sand core is used. The disadvantage of this is that decidedly more taper or draft to a hole in a pattern must be made than is necessary on the outside surface, and as the casting should have a parallel hole when finished, more metal must be removed in boring out than is the case where the hole had been cored parallel.

2nd method. Turn the pattern from a solid block and add core prints, using a vertical baked sand core. This is the method we shall follow in making the gland. The baked sand core will leave a parallel hole, therefore less metal will be required to be left for boring than would be necessary in the first method. Made in this way the gland is to be molded with the flange, Fig. 30, uppermost, the top core print being all that would be contained in the cope. The parting between cope and nowel comes, then, level with the top face of the flange. It will be noticed the top core print *A*, Figs. 30 and 31, is turned straight first and then tapered for $\frac{1}{2}$ ". This taper is given so that the cope may be lifted off easily. When the core, which has its top end tapered exactly like the top core print, is set in position and the cope is set down on to the nowel ready for pouring, if the core has not been placed quite upright its tapered end may adjust itself to the tapered recess in the cope and thus correct any slight error of position of core. For large pattern work both top core print *A*, and bottom core print *B*, Fig. 30, should be tapered, starting from the shoulder where the core print enters the pattern proper; at this shoulder, however, the core print should be exactly the size of the core, otherwise with excessive taper a useless space will be left around the core print into which metal will flow, producing a *web*, called a *fin*, around the hole and projecting from the end face.

For small work core prints for vertical cores made as shown in Fig. 31, will be found to be entirely satisfactory.

3rd method. If the casting is to be finished all over and is to be a gland for a piston rod, the outside surface of the flange must be absolutely free from blow or air holes. This will necessitate the pattern being molded so that the flange shall be downwards, in which case the under surface

comes even with the parting surface between the cope and the nowel, the remainder of the pattern being in the cope. The soundest part of a casting is always at the bottom of the mold and is more dense, heavier and stronger than at the top of the mold, as the air or gas which does not escape from the mold will leave holes in the top of casting. In molding a pattern in this manner it will be found that the pattern should be made with the flange separate, the body of the pattern and the core prints being in one piece. The flange should fit freely to a parallel surface cut on the bottom core print, the under surface of the flange coming, of course, up against the body of the pattern. For glands of medium size this method is very largely used. In cases, however, where the length of the body is about three times the diameter of the cored hole, the horizontal position is best.

4th method. If the pattern is to be molded horizontally the core prints are not tapered and the pattern must be made solid, as was the plain cylinder just described. The amount of time required for molding such a pattern will cause us to turn to the next two methods.

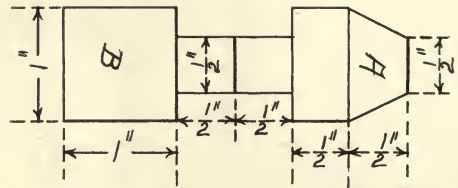

FIG. 31. METHOD FOR TURNING CORE PRINT.

5th method. Using this method the pattern is made as a split pattern, core horizontally, with the flange, which is, of course, split with the rest of the pattern, turned solid with the pattern. If the hub is small and if the flange does not greatly exceed it in diameter, this method is satisfactory. The great objection is that considerable draft is necessary on the other sides of the flange in order that the sides of the mold may not be broken when the halves are drawn from the mold.

6th method. If the hub is small and the flange is large, make the pattern as a split pattern cored horizontally, and turn two pieces for the flange separately, fitting easily a shoulder recessed in at the end of the hub of the pattern.

We will use the second method for making and molding this pattern. The right end view of Fig. 30 is in sections and shows the flange turned from a separate piece of stock, but is to be glued and nailed to the hub, making a solid pattern. If a piece of stock 2" thick is available both flange and hub are to be turned from a solid block. In this mold we require a block $4\frac{1}{2}$ " square and 2" thick. One side, which is to be the top surface of the flange, should be planed true. This side should come up against the screw centre plate. The hole for the lower core print *B*, Fig. 30, is to be turned out. The hole for the upper core print *A*, is to be bored out with a bit, the screw centre plate being removed from the lathe and placed in a vise. The pattern is removed from the lathe and turned around and screwed on the face plate, the screw entering the wood at the bottom of the hole previously turned out for the

lower core print. In this way the hole for the upper core print can readily be bored without moving or jamming the pattern fastenings in a vise. If desired the pattern may be chucked and the second hole turned out.

Fig. 31 shows the methods of turning the core prints. A block $1\frac{1}{4}$ " square and 4" long being used. The block is turned between centres and enough stock will be left at each end so that the centre marks can be removed. The core prints are to be glued into the pattern which should be held in a vise or a clamp until the glue is thoroughly hard. The two core prints must, of course, be exactly in line. No difficulty should be found in accomplishing this if the hole for the upper core print is carefully bored.

The core box for this pattern will be taken up in the next number together with other simple patterns requiring core boxes.

JOINTS IN WOOD=WORKING.

FRANCIS L. BAIN.

I. Edge Joints.

There is, perhaps, no one thing in amateur carpentry and joining which causes so much faulty work as the lack of a proper knowledge of how to make and when to use the various joints which are common to this class of work. It is, therefore, intended that the series of articles to be published under the above heading shall, if possible, render some assistance to those who may have had difficulty in securing satisfactory results when engaged in any work involving the making of joints, also to those who may not be familiar with the different joints used by carpenters, cabinet-makers, pattern makers, etc.

Only those joints that are in every way most practical will be considered, and these will be classified under two sub-headings: edge joints (for attaching edges of boards or planks together) and joints for attaching ends together.

It is necessary that, when planing stock, any appearance of a "twist" or "wind" be removed and the surface carefully "trued up". It may also be as well to mark each surface as soon as it

is finished flat and true, in the order in which it is completed, as 1, 2, 3, etc., 1 referring to the broad surface; 2, to either one of the adjoining edges, which should be placed exactly square with 1; 3 to the remaining edge after the width has been obtained from 3, and 4 to the remaining broad surface after the thickness has been obtained from 1. These suggestions simplify directions very much if they are correctly carried out.

EDGE JOINTS.

The first joint which will be considered is the plain "glue joint", also called by some the "butt joint". It is the simplest and the easiest to make. Assuming that in all cases the stock has been prepared according to the rules given above, the pieces to be glued together should be warmed a little, either in a lumber kiln or near steam pipes if possible; then the edges should be carefully and quickly covered with hot glue. (Cold glue will answer if it is not convenient to get the hot.) Place one of the pieces in a vise, glued edge up,

and putting the other piece on top of the first so the glued edges meet, rub the upper piece slowly and steadily back and forth lengthwise over the under one until any surplus glue is forced from the joint. All that now remains is to apply either hand-screws or cabinet-makers' clamps, then allow the stock to stand until the glue is thoroughly dried or "set". Quoting as authority one who has been engaged in different branches of cabinet making, stair-building, etc., for nearly thirty

years, an ample time allowance when using hot glue is $\frac{1}{4}$ to $\frac{3}{4}$ of an hour for drying for every $\frac{1}{2}$ in. of thickness in the stock being glued together.

The above joint can be used to good advantage in any position except where there is excessive exposure to the action of moisture of any kind. In the latter case the union of various pieces of stock would be accomplished by the use of the "splined" or "groove and tongue" joints, which will be described in subsequent chapters

LANTERN SLIDE MAKING.

R. G. HARRIS.

VI. Retouching Lantern Slides — Spotting — Varnishing — Masking.

Before lantern slides have the finishing touches put to them in the way of spotting and binding, it is a wise course to put them through the lantern as soon as they are dry, to ascertain beyond doubt that the density and clearness entitle them to rank as finished slides. The constant and experienced worker can gauge with certainty the quality of his slides without seeing them projected, but the intermittent worker, especially during his novitiate, may well be excused if he fails to appraise correctly the quality of his slide. It entails very little trouble, as the slides can accumulate until a convenient quantity has been made to make it worth while arranging the lantern, and once the slides are seen to be satisfactory when projected the lantern slide worker is spared the annoyance of finding that he has finished and bound up a worthless slide.

Before masking and binding the slide it should be placed on a retouching desk and carefully examined by transmitted light for defects. Of course before making the slide the negative will have been carefully spotted and all possible defects removed as neatly as can be, but in spite of this the lantern slide will require attention at the spotter's hand from defects that have made their appearance during its manufacture. As a rule, the most that can be done in the way of retouching to a lantern slide is the removal of transparent spots by filling up with color. Knife work or any process that disturbs the surface of the film is inadmissible, as, unless most skilfully done, it

shows unpleasantly on the screen. It is possible in certain cases to rub down dense portions with methylated spirit, in the same manner as is usual with negatives. But the instances when such a procedure becomes necessary do not often occur and are principally those in which it is absolutely necessary to make the best of a slide from a poor negative.

Spotting should be done by the aid of a very fine camel's hair brush and color. The precise color will depend on the color of the slide, but Indian ink and Indian red will, either singly or combined, match nearly all slides. A reading glass of low power is of very great assistance in enabling the operator to apply the color neatly to each spot. Furthermore, no light should reach the lantern slide from the back of the operator or he will fail to judge correctly the density of his spotting and find, when the slide is thrown upon the screen that all the spotting shows up darker than the transparency. The color should be kept of slightly less density than the opacity of the slide, and to ensure this being so, no light should reach the operator except that which is transmitted *through* the slide. The color should be used in quite a viscid condition, and tube colors are better than dry as the menstruum used in their preparation gives them a good working consistency.

As a rule, lantern slides on commercial gelatine plates are not varnished, nor does there appear to be much necessity for varnishing them, as the film,

unlike collodion or collodio-bromide, is not liable to be readily damaged by friction. Varnishing certainly introduces the risk of applying specks of dirt and hairs to the film along with the varnish; on the other hand, if it is well done with a clean, hard varnish, immunity is secured from fungoid growths, which not infrequently make their appearance on gelatine films, however well defended and carefully stored. Personally, I always varnish a slide of excellent quality, more especially when it has caused me considerable trouble to prepare.

The following varnish has been spoken of in high terms for varnishing lantern slides:

Saturated solution of amber in chloroform	1½ oz
Pure benzole	1½ "
Gum dammar	1½ "

When dissolved filter several times through cotton wool. Just warm the plate before varnishing and dry well over a gentle heat afterwards. It gives a bright, glass-like surface which is quite hard and does not become tacky.

A convenient and reliable varnish is made by dissolving one part of dammar in twenty parts of benzole. This is applied without heating the plate and dries with a brilliant hard surface. It is advisable in varnishing lantern slides to return the surplus varnish from the plate to a second bottle fitted with a filtering funnel and cotton wool; by so doing a stock of well filtered varnish is always maintained.

Selecting a suitable mask for any particular slide is a matter that must be left to the personal taste of the worker. It is, however, not quite the simple matter it looks at first sight. Time was when a rigorous conventionality assigned a perfect circle as the only possible shape for a lantern slide mask, then dome-shaped and cushion-shaped masks began to be seen, until at the present time the decision is left very largely in the hands of the slide-maker.

It may be said that, generally speaking, lantern slides should be amenable to the same reasoning and rules that good taste and culture apply to framing of pictures. The slide mask is, to all intents and purposes, the frame of the picture, and its shape should vary with the subject in the same way that the frame of a picture is made to do. Rectangular openings will always be in better taste than the cushion or dome-shaped open-

ings, and their dimensions should be proportioned to the subject, a very useful all 'round size being a rectangle with an opening 2¼x2" Circles are useful, but of a limited application, though for many scientific subjects they are invaluable. Commercial masks are, naturally, of stock sizes, and a well assorted selection of shapes will enable the worker to select one that will suit some subject better than it would another, but not infrequently subjects will present themselves that demand a specially cut mask to frame them most satisfactorily, and the lantern slide maker must needs become his own mask cutter.

The quickest and neatest way in which to make masks of any desired dimensions for odd subjects is to cut strips of varying widths from the best black needle paper. A supply of these strips may be cut for stock of standard widths, say, half an inch, one inch, one and a quarter inches, etc. The strips are afterwards cut up into lengths of three and a quarter inches, the size of the lantern slide. With a supply of these strips and four cut accurately, it is a very simple matter to make a rectangular opening of any dimensions by simply affixing them to the slide with a touch of gum arabic or any other adhesive that may be convenient. A pair of compasses will enable the several strips to be placed equi-distant, so that on completion the opening is perfectly true. This method is very much better in all ways for the amateur mask cutter than attempting to cut a rectangular opening in a sheet of paper.

The masks should be affixed to the film side of the slide with a touch of gum and then placed under even pressure to become set in a perfectly flat condition. If when making the slide the negative is placed on the camera with its film towards the lens, the lantern slide, when looked through with its film towards the spectator, will show the subject in its correct position. Before mounting the cover glass with the slide the title may be neatly printed on the black mask with Chinese white, utilizing the right-hand end of the mask for the purpose. On placing the slide in the lantern, if the title in Chinese white be placed towards the condenser the picture appears the right way about on the screen. If the title cannot be written in white on the mask, owing to the negative being reversed when the slide was made, the slides must bear white spot to indicate their correct position.

The cover glass having been cleaned and placed in position upon the slide, the slides have now to be bound together with the gummed strips sold for the purpose.

Binding a slide is one of those apparently easy photographic operations that is a perfect nuisance until some dexterity has been acquired. Vises, to hold the slide and cover glass firmly together while the gummed strips are being affixed, may be obtained from the dealers, and they probably help the beginner, but later on he will certainly find that his fingers are his best friends.

The gummed strips are sold either cut to the length of the slide, or in sufficient length to bind around the whole of the slide in one operation. For the beginner the divided lengths are certainly the more convenient. Four of these strips are taken, the gummed surface damped (not made wet) with a sponge and placed aside for a few minutes, gummed side uppermost, on a piece of thick felt cloth. The slide and cover glass are now taken between the index finger and thumb of each hand and their lower edges placed in the centre of the gummed strip, downward pressure on the soft felt surface sufficing to at-

tach the strip firmly to the lower edges of the slide and cover glass. On being reversed so that the edges bearing the gummed strip come uppermost, the strip can be pressed in contact with the sides of the slide and cover glass by the forefinger and thumb of each hand. The remaining sides of the slide are bound in the same manner. This is the simplest manner known to me of binding lantern slides, and I have tried a great variety, both with vises and without.

Some years ago the Photographic Club introduced a system of marking lantern slides to facilitate their being placed in the lantern so as to show correctly on the screen. It consisted of affixing two white discs of paper to the slide, on the side that gave the subject its correct rendering as regards right and left handedness when viewed as a transparency. These discs are placed at the top of the slide when it is held upright. If the slide is placed in the lantern with these discs down and towards the condenser, the view or subject is shown upon the screen correctly as to right and left-handedness. The American system of marking lantern slides is to attach one disc, known as a thumb-label, at the lower left-hand corner.

TELEPHONE CIRCUITS AND WIRING.

ARTHUR H. BELL.

II. Lines with Magneto Generator.

With the apparatus described in the last issue the amateur is enabled to establish communication between two points not more than a few hundred feet apart. In beginning this chapter we will briefly outline a circuit (Fig. 6) introducing a simple induction coil for increasing the talking efficiency, but the scope of this phone is, like its predecessor, limited by the signalling equipment; in fact, with a good transmitter and coil it matters little in the talking whether parties are a few yards or a few miles apart, line conditions being all right, for the transmitter utilizes but a small current in operation. From this we may deduce that the amount of battery current necessary in signalling over long distances would not be beneficial to a transmitter calling for 2 to 4 volts and considerably less than 1 ampere, also that the in-

troduction of resistance in the transmitter circuit would be unsatisfactory as a current cut down.

This leads us to the more modern equipment often styled the "magneto system"; a magneto being an electrical generator of the alternating type, mounted in a small wooden box and capable of delivering a voltage ranging from 50 to 70 or more, according to its size and the speed of rotation applied at the hand crank. Such a device cannot be used with a battery call bell, but requires a polarized ringer designed to accompany the generator. When the ringer is connected by two wires to the magneto generator and the crank rotated briskly, the signal will be given even though the instruments are several miles apart. Thus, in using these devices, the number of cells of local battery need never be more than two at

either end.

Relative to magneto equipments, the price of standard machines is so low that no similar contrivances could be completed at home for anywhere near the price, hence a description of both

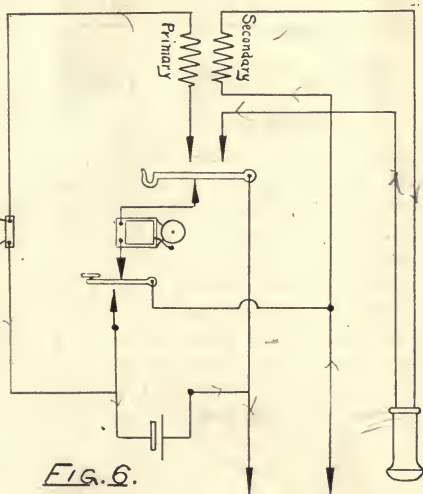

FIG. 6.

bell and generator construction is not essential at this point. Induction coils for the talking circuit may also be purchased at about wire prices.

Fig. 7 shows in detail a circuit for one end of a bridging magneto private line. In this diagram the bell and generator are shown separated one from the other, that the equipment may be fully understood but it, is generally the custom to purchase these set up in one box, the hook for the receiver being at one side, the crank handle on the other and the gongs and transmitter on the front, which is usually a cover to the box, and with two binding posts at the top to take the line wires. Batteries for the transmitter may be placed close at hand or stored some distance away and connected by insulated wires with the circuit.

In this diagram it will be noticed that with the receiver on the hook, a ring from the other end operates the signal bell. In ringing with the generator the pressure of the hand in rotation causes a circuit to be completed by the armature spindle bearing upon a spring and ringing your own bell as well as the distant one. When the receiver is removed from the hook the two lower contacts

are made common with the hook, thus putting the receiver, transmitter, battery and coil upon the line for talking. Should this private line comprise more than two stations the bell coils of such instruments as are not in use are, of course, across the line, but owing to their form of construction and high resistance, they act as a choke to the voice currents and keep them on the line.

Different manufacturers employ various methods of wiring bridging telephone sets, each having some special qualification. The one here shown is common to a number of good systems and should be closely studied by the amateur. Nearly all dealers supply customers with working diagrams when same are requested.

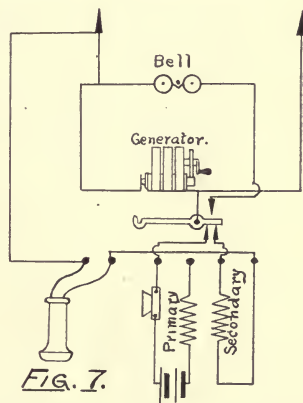

FIG. 7.

Wires for outside construction may be of No. 12 galvanized iron wire, and as conditions for line work vary in different localities, the subject of lines passing over other than one's own territory will be treated in another chapter. On one's own property wires may be run circuitously through trees to avoid setting poles, but care must be taken to insulate the wires from all substances likely to give trouble. Insulators of glass to fit on wooden pins and porcelain affixed with screws or spikes are commonly used.

In running such lines separate the wires a full foot from each other, using care that a sag in the one does not throw it against the other or against some conductor that will cause trouble.

Where wires enter buildings some certain means of protection must be provided. Carbon and fuse arrestors are for sale by dealers in tele-

phone equipments generally, and may be depended upon to protect both instruments and property when well installed, from foreign currents upon the line. Lightning, which is oscillating in character and of enormous voltage, often strikes contiguous to telephone lines and a certain amount of the charge passes to the arresters, where it enters the ground without damage. No device has been provided that will ensure safety should lightning discharge directly upon the circuit near the instrument. The modern carbon arrester and fuse block, however, may be depended upon in practically all cases except the foregoing, and as types and methods of installation vary, a diagram will not be presented here, that being usually supplied by the dealer.

All protecting devices, however, are placed just inside the building as near the point of entrance as possible. The outside line ends, usually on two glass or porcelain insulators, supported on wooden or iron brackets. The wiring from this terminal to the lightning arrester inside the building should be heavily insulated with rubber and take separate holes where entering. The usual form of arrester has five binding posts — two for the line, two for the instrument side, and one additional to which is connected a heavy wire, known as a ground wire of value only as a discharging circuit to earth for foreign currents breaking in on the line and causing the protecting device to operate. At no time does this ground wire enter into the talking circuit.

In the next chapter will be given a diagram of a simple interior outfit with several stations wired suitable for room to room communication.

TWO ELECTRICAL FORMULAS.

There are two formulas for electrical measurements which every amateur electrician should memorize. They enter into all sorts of calculations in telephone, telegraph, electric light and general experimental work.

First: — The combined resistance of two parallel circuits, may be found by multiplying the resistances together, and dividing by the sum of these resistances. Where there are several circuits in parallel, any two are treated thus, and the result combined in the same way with the re-

sistance of another circuit, and so on to get the final resistance. For example: — The amateur has planned a circuit as in Fig. 1. One shunt measures 50 ohms, and the other, 100 ohms. The combined resistance will be equal to 50×100 , \div by $50 + 100$, = $33 \frac{1}{3}$ ohms. If the amateur

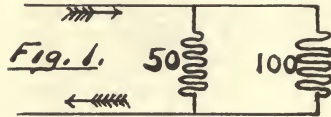

should conclude to add on another shunt of say 2 ohms, (see Fig. 2,) he should consider the problem resolved into two factors, the $33 \frac{1}{3}$ result of the previous calculation, and the new shunt of 2 ohms, = $33 \frac{1}{3} \times 2$, \div by $33 \frac{1}{3} + 2$.

Now it becomes evident to the amateur, that, knowing the combined resistance of these shunts, he may calculate by Ohms law ($C = E \div R$,) just what effect this combined resistance will have on the amount of current. Yet it must not be presumed that any one of these shunted resistances is to carry more than its prescribed portion of the current. And to ascertain just how many amperes each shunt is taking we must follow a rule that, in such a divided circuit, each shunt carries a proportion of current, inversely proportional to its resistance.

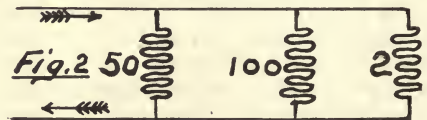

In explanation, note down for each branch or shunt, the reciprocal of its resistance. Then reduce these fractions to a common denominator, and add the numerators together. Use this sum of the numerators for a new common denominator, and the original individual numerators as numerators, and the resulting fraction will show what part of any current that may be in use will pass through any one of the shunts. For example, using the shunts of the previous example: $\frac{1}{50}$, $\frac{1}{100}$, $\frac{1}{2}$, common denominator, is 100. New fractions become $\frac{2}{100}$, $\frac{1}{100}$, $\frac{50}{100}$, $2 + 1 + 50 = 53$. Following the rule above given, we calculate that the first shunt of 50 ohms carries $\frac{2}{53}$, the second or 100 ohm shunt, carries $\frac{1}{53}$, and the last, or 2 ohm shunt, carries $\frac{50}{53}$. The total, or $\frac{2}{53} + \frac{1}{53} + \frac{50}{53} = \frac{53}{53}$ or unity.

HIGH FREQUENCY PHENOMENA.

H. E. DILL.

Principles of Coil Construction — Wehnelt Interrupter.

The Ruhmkorff coil, with its many turns of fine wire coiled in sections and combined together to form a secondary, has been so long an indispensable part of a well equipped electrical laboratory that I shall make no attempt to describe in detail all of the principles of operation, but refer the beginner to one of the numerous elementary works upon electricity. It is advisable, however, to point out the basic laws as discovered by Faraday and others seventy years ago, in order to make clear the general arrangement of all coil windings.

First of these principles is where you have two distinct circuits contiguous to each other, but not in contact, and by exciting an electric current in one of them instantly induce, that is, produce by induction, an electric current in the opposite direction in the other. And if the current in the originating circuit is suddenly interrupted, a secondary current will momentarily be induced in the secondary circuit, but in this case in the same direction as the first current. It follows that if we alternately open and close the primary with some rapidity we shall induce in the secondary circuit a current continually changing in direction. As to the characteristics of these alternations further observations will be made later.

The second principle relates to the rapid movement of a magnet in proximity to a conductor or of a conductor in proximity to a magnet—developing an electric current in the conductor.

Thirdly, a bar of iron may be rendered powerfully magnetic by being placed in the vicinity of an electric current. This magnetism will continue while the iron remains under the influence of the current.

In a device possessing these features, namely, a soft iron core; a coil of wire encompassing the core; a source of current to pass through the coil, thus energizing the core; a secondary coil of wire insulated from but encircling the primary winding and the core; a means of interrupting at will

the source of the primary current,—these are the factors in induction coil building.

The actual E. M. F. of the primary circuit remains practically unaltered, but the E. M. F. of the resulting secondary current is greatly increased from several causes. One is the great length of wire in the secondary, coiled in many turns in the field of magnetic influence. Second,

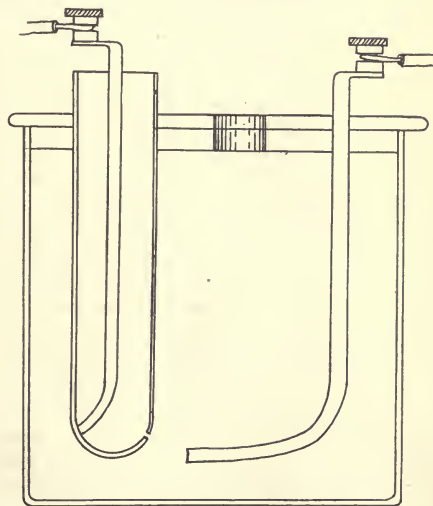

WEHNELT INTERRUPTER.

the rapidity of interruption constantly produces a magnet in proximity to the secondary winding and as quickly takes it away, and this rapid magnetization and demagnetization of the core intensifies the current already intensified by the cutting of lines of force. It is to be remembered that this continual making and breaking of the primary circuit causes the secondary to be further intensified by the alternations of current.

In coils bearing condensers in connection with core-energized interrupters, the condenser plays an important part in intensifying the secondary circuit, for as previously explained, the

induced alternate currents depend on the make and break of the interrupter, but it is also a fact that the breaking of the primary circuit momentarily produces by induction a slight extra current in the same direction, in itself a phenomenon called self induction. This self-induced current is absorbed by the condenser at the moment the primary circuit is broken, only to be discharged a moment later through the primary coil, thus creating a current in the opposite direction to the battery current, and thus assisting in demagnetizing the core and greatly adding to the efficiency of the coil.

Having now explained the method of intensifying a source of current by induction, I will describe one type of interrupter, whose invention some years ago opened a new era in high frequency work. I refer to the Wehnelt or Electrolytic break, for which is claimed interruptions as high as 2000 per second when operated direct connected with incandescent mains.

As far as personal experience points out, when used with ordinary coils this interrupter varies from 250 to 1500 per second, depending upon the size of the electrodes (to be described), the inductance of the circuit and the value of the E. M. F. With specially designed coils, frequencies far in excess of these have been reached in the secondary discharge by using special capacities in that circuit. The subject of calculating these frequencies is now a foremost problem in this branch of science. The pitch of an interrupter is a rough range or measure of its breaks, and it is reasonable to suppose that its range of sounds is the limit of its rate of break, but where the variance of sound precludes estimate, by what are we to be governed? It is not advisable at present to describe the complex devices for frequency measurement, because many of the results have been questioned, although the rotating mirror method and calculations based on the inductance and capacity values have demonstrated that sinusoidal currents with a frequency of 400,000 cycles may be produced by special and elaborate apparatus.

In the older forms of vibrators using platinum contacts, primary voltages of 100, or more, gave but meagre results owing to the heating and blackening of the platinum and the low rate of interruption, but with the introduction of the Wehnelt there was opened a new field of research.

This interrupter, a sketch of which is here given, consists of a glass jar, filled with water slightly acidulated with sulphuric acid. In this solution is immersed a lead plate and an insulated platinum point, the plate being connected to one terminal of the electric current supply and the platinum point to the other. A suitable adjustment of the two electrodes gives rise to current interruptions of a high and varying frequency.

Because of the effect of current action on the platinum tip, and being unable to find a less expensive and equally satisfactory metal, many experimenters were led to substitute in its place a small glass bottle having an extremely small hole drilled near its base. In this bottle was placed a strip of lead which was connected with one side of the source of current.

The conductivity of the electrolyte was not only benefited by the addition of more sulphuric acid and a small quantity of magnesia sulphate to the water, but the number of interruptions seemed also to be increased and operations started at a lower voltage.

As to its general adaptation to amateur work, it is well to note that it is generally the custom in designing a high potential coil to consider frequency of interruption and insulation together for the penetrative effect of a rapidly broken magnetic field may imperil an insulating medium ordinarily secure under a low rate of interruption. Oil used as a dielectric, saturates the windings and being liquid becomes self-sealing should by chance a stray discharge pass from one part of the secondary to another. Hence the use of transeal oil and similar oils in many grades of transformer work.

The Niagara Falls electrical output is so enormous, that nearly one-half of the horse power required to operate the vast amount of machinery within the limits of Buffalo City comes from this one source. And yet the present system of supplying electrical energy from Niagara Falls to Buffalo was inaugurated barely five years ago.

The system of identification by finger prints, which was introduced into use recently, has been used in Korea for many centuries in the deeds for the sale of slaves. The slave was required to place her hand—all the slaves were women—upon the sheet of paper on which the deed was written, and the outlines of the fingers and thumb were traced, after which an ink impression of each of the fingers was taken.

AMATEUR WORK

77 WILBY ST., BOSTON

DRAPER PUBLISHING CO., PUBLISHERS.

A Monthly Magazine of the Useful Arts and Sciences. Published on the first of each month for the benefit and instruction of the amateur worker.

Subscription Rates for the United States, Canada and Mexico \$1.00 per year. Single copies of any number in current volume, 10 cents.

TO ADVERTISERS.

New advertisements, or changes, intended for a particular issue, should reach the office on or before the 15th of the previous month.

Entered at the Post-office, Boston, as second-class mail matter Jan. 14, 1902.

JULY, 1904.

Sport, pastime, enjoyment seem to engross the minds of many of the young men of today to the almost entire exclusion of anything else. While these are right and proper, even beneficial in their way, there are limitations, and these limitations require that the probable future vocation should receive consideration, and a reasonable portion of time be given for preparation toward it. In view of the increasing number of capable young men in situations unsatisfactory to themselves, a brief study of the causes leading thereto is instructive. In general, it will be found that during youth and early manhood no great attention was given to obtaining an adequate knowledge of some trade or business. Therefore the business career is commenced with no substantial foundation. Adverse circumstances, in such a case, are productive of disastrous consequences, the worker not having attained to that skill, or acquired the knowledge for which there is always an unsatisfied demand.

It is, therefore, of decided importance to the future prosperity of every youth that he, early in life, forms definite conclusions as to the general trend of his future business career, and thenceforth utilizes every available help which presents itself. Only in this way can he reach the position of being better than the *ordinary*; that is, the man who is wanted, instead of wanting.

The man who knows something thoroughly, can do something well, is the man who arrives.

During the months of July, August and September an extra one-subscription premium will be given to anyone sending in three subscriptions. As many of our readers will, during this time, be enjoying their vacations, they should find it easy in this way to obtain some valuable additions to their tool kits.

We will also during these months give to anyone sending \$1.25, a year's subscription to *AMATEUR WORK* and a choice of either of the following books:—

Norrie's "Induction Coils" or Avery's "A, B, C of Dynamo Design." The first of these books contains much of value to those interested in coil making; the latter book is undoubtedly the best presentation of the elementary principles of the subject to be obtained and just the book for amateur dynamo and motor builders.

The "poison squad" utilized by Dr. Harvey W. Wiley, chief chemist of the American Agricultural Department, in experimenting with adulterated food products, was disbanded on May 21. The twelve young men have eaten nothing but adulterated food since early in January. Everything has been more or less tinctured with salicylic, sulphuric or benzoic acid. The experiments were a continuation of those begun a year ago to determine exactly the actual effect of food preservatives on the human system. Such acids were used as are employed by domestic and foreign packers in preparing meats, butter and other products for shipment. The acids were at first placed in the food, but subsequently given in capsules. The most accurate record was kept of the men's condition. It is said some of the men have materially deteriorated in health as a result of the acids administered to them. All are said to have been affected by the drugs used as food preservatives. No details as to results will be given out until a formal report is submitted to Congress.

A narcotic bomb has been invented by a surgeon in the Austrian army. The bomb, which may be fired from any gun, has a time fuse, and when dropped among a regiment of the enemy will not explode, but will fill the air with narcotic gases strong enough to make 2000 men unconscious for several hours. While in this condition they may be captured, and when they wake up they will feel no bad effects of their experience beyond a slight headache.

The whirling winds of Arabia sometimes excavate sand pits to the depth of 200 feet, the rim usually being three times that length in diameter. A sand pit thus may be entirely obliterated in a few hours and another excavated within a short distance of it.

HOW TO BUILD A 12-FOOT ROW-BOAT.

CARL H. CLARK.

A boat of the type and size to be described is a very convenient boat for rowing on a lake or on the salt water, and also makes a good tender for a yacht. The dimensions, 12' long by 4' wide, make a boat which, while easy to row, is yet wide enough to carry well and be very stiff.

The usual method of recording and transferring the lines of a boat or yacht is by a "Table of offsets" such as is here given, and the amateur boat builder should accustom himself to working from it, as it saves him the trouble and inaccuracy of scaling from the printed drawing. The figures given are taken by the designer from his original drawing and are, of course, more accurate than any which the builder could take from the small printed plans. The water lines, or lines parallel with the base line, are 3" apart, while the cross sections are 3' apart. In Fig 3 it will be noted that the water lines cross all the mould lines and the distance on each water line from the central line to its intersection with the mould line, is the offset given in the table. The figures along the top of the table correspond to the numbers of the moulds in Figs. 1 and 2. The two top lines marked "height of sheer," and "height of rabbet," give the height of the sheer and rabbet above the base line on each mould. The lines below give the half breadths of each mould on each water line before referred to. For instance, to find the half breadth of mould No. 2 on waterline No. 3, the vertical column numbered 2 at the top, and the horizontal row headed No. 2, 3 at the side are each followed until they meet and the required offset, 2, 3 $\frac{1}{2}$ " is found.

FIG. 4. LAYING DOWN TABLE.

	1	2	3	Stern
Ht gunwale above base	2'-1"	1'-10 $\frac{1}{2}$ "	1'-10 $\frac{3}{8}$ "	2'-0 $\frac{3}{8}$ "
" rabbet "	"	"	-0 $\frac{3}{8}$ "	9"
$\frac{1}{2}$ breadth-gunwale	1'-7"	2'-0"	1'-10 $\frac{1}{2}$ "	1'-4 $\frac{1}{2}$ "
" " " w. L.	6	1'-6 $\frac{3}{8}$ "	2'-0"	1'-10 $\frac{1}{2}$ "
" " " "	5	1'-6 $\frac{1}{8}$ "	1'-11 $\frac{3}{8}$ "	1'-10 $\frac{1}{2}$ "
" " " "	4	1'-5 $\frac{1}{2}$ "	1'-11 $\frac{3}{8}$ "	1'-9 $\frac{1}{2}$ "
" " " "	3	1'-3 $\frac{3}{8}$ "	1'-10 $\frac{3}{8}$ "	1'-8 $\frac{1}{2}$ "
" " " "	2	1'-0 $\frac{3}{8}$ "	1'-8 $\frac{3}{8}$ "	1'-5 $\frac{3}{8}$ "
" " " "	1	-8 $\frac{1}{8}$ "	1'-2 $\frac{3}{8}$ "	10 $\frac{3}{8}$ "

The shapes of the moulds should be laid off first, each on a separate sheet of thick paper. A centre line is drawn, and also the correct number of water lines 3' apart at right angles to it. The proper offsets are then read from the tables and set out on the water lines, being laid off on both sides of the centre line to obtain the complete outline of the mould. At the foot it is made the same width as the keel, 14", and the up-

per end is laid according to the height from the line headed "height of sheer," and of the breadth given in the line headed "breadth of sheer." Through the points thus obtained, a smooth curve is drawn with a limber batten. It may not be possible to make the line pass exactly through all the points, an error of $\frac{1}{8}$ " or so being allowable, but it should be a fair average of all the points and must, in any case, be fair and smooth. The curve thus obtained is the shape of the boat to the outside of the planking, but since the mould fits inside of the plank a new curve must be drawn inside of that just drawn and distant from it an amount equal to the thickness of the plank, in this case $\frac{1}{4}$ " This new outline must also be 1 $\frac{1}{2}$ " wide across the foot, and is the shape to which the mould is made. The moulds are made as in Fig. 5. of rough pine or spruce, but well braced and strong. The centre line is marked across, as shown, for use in setting up. The stern is worked out of a piece of oak or mahogany 1" thick. The shape shown being that of the after face, the edges must be left with a considerable amount of bevel which is later trimmed down so that the plank will lay on evenly. The outline on the stern board should be cut only as high as the gunwale line, and above that the board should be allowed to extend out over the plank.

A pattern should also be made of the stem along the rabbet line, and also of the deadwood at the stern end. The framing of the keel, stern and deadwood is shown in Fig. 6. The keel is 2 $\frac{1}{2}$ " deep and 1 $\frac{1}{2}$ " wide, tapered at the ends to 1 $\frac{1}{2}$ " wide. The stem is 1 $\frac{1}{2}$ " thick at the rabbet line and is cut from a natural crook knee. The shape of the rabbet line is marked on from the paper pattern, and the outer and inner outlines are each 1 $\frac{1}{2}$ " away from and parallel with the rabbet. At the rabbet line a rabbet is to be cut, as shown in the section of the stem, to take the ends of the plank. It can be cut only approximately now and trimmed out later after the stem is set up. The stem is fastened to the keel, as shown, with galvanized iron rivets. At the after end of the keel the stern post and deadwood are to be set up. The stern post has a tenon cut on its lower end which fits a corresponding mortise in the end of the keel, a pin being driven through. The angle of the stern post must be carefully adjusted and correct. The deadwood is the same thickness as the keel and is shaped according to the pattern already gotten out, the rabbet line being marked on both sides of it and the upper edge being cut $\frac{1}{8}$ " above and parallel with the rabbet. It should be noted that the rabbet being the joining line between the surfaces of the plank and the keel, is about $\frac{1}{8}$ " below the top edge of both keel and deadwood in order that the inner edges

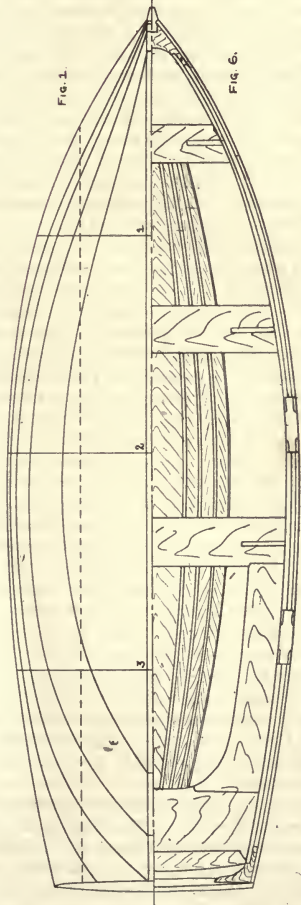

Fig. 1.

Fig. 6.

Fig. 5.

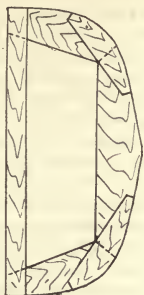

Fig. 2.

Fig. 3.

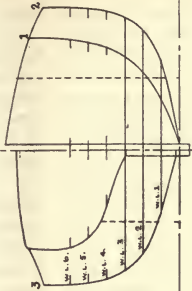
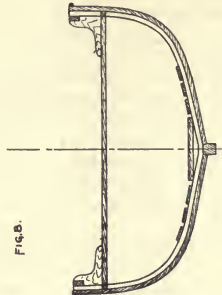

Fig. 7.

Fig. 8.



of plank and keel may be even. The deadwood is fastened in the angle between the keel and the stern post with rivets and screws. The stern board is set into the stern post as shown. The rabbet line is extended up across the stern post, and the stern board is set down to about $\frac{3}{4}$ " of the rabbet line, so that when the outer surface of the $\frac{1}{4}$ " plank is even with the rabbet the inner surface will lie upon the stern board. Care must be taken to set the stern board level and also square with the keel, when it may be fastened into place with rivets.

In setting the boat up for planking, the keel is supported about 18" from the floor and the stem and stern firmly braced in the correct position. The moulds are then set up in their correct positions. Moulds Nos. 1 and 2 are set with their after faces on the mould point, and No. 3 with its forward face at the mould point. The keel should be supported under each mould, and each mould braced firmly against the keel so that there will be no tendency for the mould to rise out of place under pressure. A line stretched from the centre of the stem to the middle of the stern board will aid in getting the moulds up right, and a carpenter's square will help to get them square with the keel. A batten, or thin strip of board is now laid on the moulds and stern board and the latter bevelled off until it lies flat upon them. The rabbet in the stem is cut out until the $\frac{1}{4}$ " plank will bend around the moulds and fit even with the surface of the stem. The $\frac{3}{4}$ " of keel and deadwood just above the rabbet is bevelled off flat until it is square with the moulds, so that the plank will lie on the moulds and bed squarely against this bevelled edge. When the rabbet is trimmed out, a $\frac{1}{2}$ " hole should be bored in the rabbet at its intersection with the joint at each end of the keel and a pine plug driven in; this plug prevents the water from running along the joints and into the boat.

The plank is of $\frac{1}{4}$ " pine, well seasoned and clear, and in 14' lengths. If desired the boat may be planked up on frames in the ordinary manner, but this is not considered advisable at present unless the amateur has had considerable experience in boat building. The method to be outlined is one which is in common use for fishing boats and others. It is a very strong and tight method of building and very easy to construct. The planks are obtained in strips about $1\frac{1}{2}$ " wide, and if planed to order should be slightly thicker than $\frac{1}{4}$ ", as some planing will be required to finish. The planks are put on one at a time and edge nailed, each one to the one below. The girths of each mould should be divided into the same number of parts, and each strip tapered from the middle towards the ends to allow for the decreased girth at the ends of the boat. The first streak is nailed to the keel and twisted into the rabbet at the stem; the ends of the lower streaks should be kept about horizontal and be allowed to run off to nothing on the stem and deadwoods. It is edge nailed to the keel with about 3" galvanized wire nails. These nails should be galvanized, small-head, finish nails, from 3" long down to $1\frac{1}{4}$ " and of small wire. They are

driven about 4" or 5" apart.

Each streak is planed before putting on and tapered at the ends. The edges should be painted with lead before fastening. A small hole should be bored for the nail before driving, as in this way the nail can be driven straighter with less chance of splitting out. At the ends, where the strips are tapered, shorter nails must be used. Great care will be necessary in driving the nails not to split the strip below. The strips should also be nailed flat to the stern with about $1\frac{1}{2}$ " nails. The strips are put on one after the other, and as the turn of the bilge is reached the edges are slightly bevelled to give the curvature without causing an open seam outside. In driving the nails in one strip, care must be taken to avoid the nails in the strip below. At the stern, also, the plank is fastened to the stern board. As the plank is being put on, the remaining girth of each mould and the stem should be watched to be sure that the top strips are coming out even without its being necessary to work in any uneven pieces to fill up. It should be so figured that the top strip will come to the gunwale line as marked on the moulds and stem and fit up neatly under the projection on the stern board. The lower strips of the bottom will be found the hardest to put on on account of the twist at the bow, but by nailing first amidships and using one or two monkey wrenches to twist them into place, little difficulty will be found. The upper streaks should be started from the bow, working towards the stern. The edges of the strips should be kept as even as possible to have little to plane off. The ends of the strips should be cut off even with the after face of the stern board. Great care must be used that the first few strips at the bottom are kept in close to the stem forward as there is a tendency to form a bulge at this point unless careful attention is given to it. The outside of the boat is now to be planed and smoothed up. On the bilge enough should be taken off to make a round, smooth surface. After being planed the surface is to be rubbed down with sandpaper.

Although with this method of building, frames are not necessary it is thought advisable to work in a few "biners," or small oak frames about 1x2" and about 12" apart. They should run from gunwale to gunwale in one piece except at the ends, where they will need to be in two pieces. They are fastened to the plank with copper or galvanized nails; if the former, a burr should be shipped on before riveting. The moulds may now be taken out, watching carefully to note any tendency to spring out of shape. The boat should now be painted both inside and outside with a priming coat. Braces should be placed inside the boat to prevent any change of shape.

The gunwales running around on the inside of the frames even with the top of the plank, are of oak, 2x $\frac{3}{4}$ ". They run all fore and aft, being let into the knees at the ends, as shown in Fig. 7. The knees are natural crook about 1" thick, the overlap of the gunwale and knee being about 4"; the gunwale is tapered on the under side to the same thickness as the knees, and

knee, gunwale and plank are fastened with copper rivets.

The top edge of the stern board is rounded over, as shown in Fig. 3, and the stern post and keel are tapered down to $1\frac{1}{4}$ " at the keel. The stem is trimmed down to $\frac{5}{8}$ " thick and the forward end of the keel is tapered to meet it. The top of the stem is cut off even with the forward knee and the face of the stem is fitted with a brass half round strip.

The seats are arranged as shown in Fig. 6. To support them a strip is fastened with rivets around on the inside of the frames about 7" down from the top of the gunwale on each side running from stem to stern. The seats rest upon this strip. They are 8" wide, preferably of hard wood, although soft wood may be used if the boat is to be painted all over. On the two middle seats two knees are fitted as shown, and on the forward seat, one knee. These knees are shaped to fit the curves of the side gunwale and are fastened to it by a rivet. These knees greatly stiffen the boat and prevent her warping. On the outside upper edge of the top a half round oak moulding about $\frac{5}{8}$ " diameter should be fastened to give a finish.

In the bottom of the boat a $\frac{3}{4}$ " board about 9" wide is laid in the middle flat, being tapered at the ends to fit the boat and supported by short blocks; it will need to be in two pieces to pass between the seats, and each part is held down by a button so that it may be removed for cleaning out the boat. On each side above the middle board, 3 narrow strips $\frac{1}{4}$ " thick and 2" or 3" wide are fastened inside the frames, leaving a space of about $\frac{1}{2}$ ". To make these strips two of the strips before used should be bent to the required curve and nailed together edgewise, forming a wide strip with the necessary bend or camber. The edges should be

bevelled, and they may be fastened in place permanently. The upper strips may be each shorter than the one below.

A heavy ringbolt is to be fastened on the inside of the stem just below the knee, to fasten the painter or mooring rope to.

A back board should be made to fit between the stern knees about 3" away from the stern board. Its top should be rounded rather more than that of the stern board, and it is held in place by cleats on the stern seat and small chocks on the gunwale. The name of the boat is to be put on the back board.

A rudder should be made, shaped as shown, of a solid board with a cleat across the lower edge. The top of the rudder is cut down to have a shoulder, front and back, to support the rudder yoke, the top being rounded over with a hole for the pin above the yoke. The rudder is fastened on with braces and eyes such as are sold for the purpose.

To support the rowlocks, oak blocks about 8" long are fastened on the top of the gunwale and top strip with screws. The best position for the rowlock is a matter of trial, but 12" from the edge of the seat is right for the average person.

The boat should be painted two or three coats inside and out before putting into the water. It is suggested that the stern board seats, gunwale and half round moulding be finished in varnish. No calking is required, but any small cracks may be filled with putty after she is rubbed down with fine sand paper.

The boat thus built will remain tight for many years; it should never be calked, but after being stored for a season should be painted and allowed to swell up in the water when she will become tight again. The oars for this boat should be $7\frac{1}{2}$ ' to 8' long.

SOLDERING.

H. M. CHADWICK.

I. Plain Soldering.

The articles necessary for doing ordinary soldering are the flux, the scraper (an old knife will answer very well for the latter) the iron and the heater.

The Flux. This is a fluid made from acid that must be used to coat all surfaces to be soldered. Good soldering fluids may be purchased at the hardware stores, but as satisfactory a one as any can be made by pouring a tablespoonful of hydrochloric acid over a piece of zinc the size of a half dollar. Let the acid act until the zinc is taken up. Strain the resulting fluid, which is zinc chloride, and put it into a bottle with a glass stopper. It will keep a long time. Avoid bringing the fingers in contact with the flux, as it makes the skin sore.

The Iron. The soldering iron is really not an iron at all, but a piece of copper fitted with a handle. For ordinary work, use an iron about 3" long $\frac{3}{4}$ " to 1" in diameter. Smaller ones are good for very small work but will not hold the heat long enough to do a good job on a seam several inches in length.

Make a cleaning pad from a piece of old cloth folded into several thicknesses and tacked to a board.

To prepare the iron for use, file the end for about an inch from the point bright and smooth and heat it very hot, but do not let it get red.

Wipe the hot iron clean on the cloth, dip the bright end into the flux and apply it to the end of a stick of solder. If the iron is hot enough the solder will melt

and stick to the iron. Let a few drops fall to the cloth and rub the iron around in the molten solder. This will *tin* the implement thoroughly.

The Bunsen burner is a good thing over which to heat an iron, provided there is gas in the house, but a coal fire does very well, though it is not so clean.

Suppose, now, one wishes to mend a hole in a tin pan. Scrape a surface around the hole equal in area to that of a dime, using an old knife or, perhaps, a piece of emery cloth, being sure to remove all grease and dirt. Do not even rub the place with the fingers after getting it clean. Apply a little flux with a brush or a piece of clean wood. Cut a piece of solder from the stick the size of a small pea and place it over the hole. Next, rest the iron, well heated and tinned, on the cold solder, and the latter will melt at once and spread over the cleaned surface.

To prevent the solder from running through the hole, rest the pan on a flat piece of wood, thus bridging the opening. Another and better way is to smear a small quantity of plaster of Paris on the under side of the pan.

Agate ware can be mended in this manner as well as plain iron and tin. Chip off the agate covering with a

few careful blows from a hammer or the blunt end of a heavy file. Scrape the metal clean and solder as directed.

To solder a seam, such as the lapping edges of a tin box, proceed as already stated, but tilt the box slightly so that the solder will tend to run downwards and fill the seam. The molten solder will follow the iron as it is drawn along the crack, provided the iron is hot enough and well tinned.

Never cool soldered articles by dipping them into water. Solder sets better if allowed to cool in the air. If the molten solder collects in little balls and refuses to spread over the cleaned surface, there is dirt or grease present. If the solder melts but does not run and collects in pasty bunches, the iron is not hot enough. If the melted solder refuses to follow a good hot iron, then the iron is dirty and had better be filed and retinned, or at least rubbed on the cloth.

The novice will undoubtedly waste much solder, in spite of careful effort, but this fact should not discourage him, as a little practice will teach him to avoid this error. The next article will treat of the blowpipe and Bunsen burner and their uses in connection with soldering.

CASTING IN SOFT METALS OR ALLOYS.

The casting of metals having a low fusing-point is one of those things which is well within the reach of the amateur or professional caster, provided he has certain of his alloys made for him, and he can have a range of temperature for his metals and alloys from about 96° Fahr. to about 1,500° Fahr., and for melting these an ordinary plumber's furnace or a portable forge will provide sufficient heat. As to hardness, these metals and alloys can be had from the softness of the softest solder or tin to that of cast iron, and with tensile and bending strengths up to moderate steel, and they will stand friction well, particularly when properly lubricated. Great heat they will not stand, as a matter of course; but many will stand from 250° to 400° Fahr. without injury. The cost is that of brass and bronze, if the alloying is done at home; but of course, when made out, the cost of alloying has to be considered.

Where alloys are made it is usual to melt the most refractory metal first and then to add the others according to their fusing-points, afterwards pouring into bars or slabs, remelting to secure uniformity, and then running into bars or narrow slabs, the latter—poured on edge—being about 3" wide and $\frac{1}{2}$ " thick for convenience of quick melting at a moderate heat.

The metal referred to in this paper can be cast in iron moulds, in plaster and fine Bath brick moulds, or in ordinary sand—weak loam—moulds; the system of moulding with sand or plaster moulds being the same

as for brass, except that the sand moulds should not be rammed so hard as for brass. The harder metals and alloys should not be cast in closed iron moulds; but they do well in "strip" or "ingot" moulds open at top, previously dressing the moulds with whiting or plumbago; in trade foundries each one having its own preference.

Probably the amateur would find it easier to use plaster and Bath brick moulds, as with these there is only the minimum of difficulty. In the first place, Bath brick is reduced to powder when perfectly dry, and after passing the powder through a 30-mesh sieve, it is mixed with fresh plaster of Paris at the rate of about two-thirds plaster and one-third Bath brick, passing the mixture through a 16-mesh sieve to insure thorough mixing. Plaster by itself is not sufficiently refractory, but when mixed in the proportions mentioned it will answer for any metal with a fusing-point no higher than brass, providing the bulk is not too large. The moulds should be made in halves, and provision must be made for pouring the metal and the escape of air, on which points the operator must use his judgment; but as the alloys mentioned pour "dead," there is little difficulty so long as the air has sufficient outlet. When made, the moulds should be thoroughly dried, and before pouring they should be clamped together and weighed down to prevent lifting. Damp moulds are liable to explode and to cause bad castings; therefore the matter of dryness should be

closely studied. Where the castings are to be turned or otherwise machined, facing is not required, but where extra smooth castings are needed the moulds should be dusted with fine plumbago—not stove polish—before they are quite dry, and if this is brushed over with a soft brush and the moulds blown out with a pair of bellows when dry, the castings will have a fine face. Ground steatite may be used instead of plumbago, if preferred.

The metal or alloy should be melted until it is fluid; but no excess of heat should be allowed, and when it is being run into the moulds it should be poured steadily and with quickness; otherwise the moulds will run faint. Of course the crucibles should be skimmed, and no dirt or oxide allowed to get into the moulds.

An alloy that is easily melted and which has a strength approximating to that of steel, is composed of 75 per cent aluminium, and 25 per cent zinc, and this costs about 37 cents per pound for metal, and if the alloy is made for you, about 40 cents per pound. It is about half the weight of cast iron and, therefore, bulk for bulk, should cost about the same as brass at 8½¢ per pound. This alloy is largely used for toolmaking and other trade purposes, and wears well.

A harder alloy, which will stand a good amount of strain, is made from 66.66 per cent aluminium and 33.33 per cent zinc; but it is more of the nature of cast iron. This costs 32 cents per pound for metal, or is 86 cents per pound if made up into bars. As compared with brass in bulk, it runs out at a fraction less than the preceding. The writer has seen some very decent faceplates, angle-plates, and the like, made with this metal, but the preceding formula would give better results.

A third alloy may be mentioned in regard to strength, and which will bear some amount of hammering, and is composed of 65 per cent aluminium, 30 per cent zinc, and 5 per cent copper, the cost of the metals being about 32 cents, and bulk for bulk, compares with gunmetal at about 17 cents per pound, or in other words, castings in the alloy are about one-third cheaper than gunmetal.

Zinc broken down with copper—say, zinc 88 per cent, and copper 12 per cent—is useful for a great many purposes where strength is not required, and the alloy costs about 6 cents per pound, or, say, 8 cents, when made up to order.

When there is no crucible furnace at hand, the alloys mentioned above should be made by a brass founder or other alloyer, and the amateur should receive them in bars or small ingots ready for remelting. A fair price to pay for making alloys of a simple character is, roughly, a penny per pound, but large quantities would cost less. In no case will 100 pounds of mixed metals produce 100 pounds of alloy, as there are unpreventable wastes in making alloys. Loss differs somewhat with the metals used, and also with the skill of the alloyer; but in most brass foundries there is considerable skill shown in preventing undue loss.

With the alloys shown above it should be possible to

work out any idea in metal except where temperatures over 300° Fahr. are concerned, and inventors would with these be able to secure absolute security, as they might very well make the whole of their models.

Fusible metals of a low fusing grade could be dealt with wholly in the amateur's workshop, and in melting for the making of alloys, if care be taken to melt the most refractory metal first and then add the other metals in accordance with their fusing-points, success will, as a rule, be secured. It is, however, not well to try to add zinc to copper until you have seen it done, as it splashes a great deal; nor should aluminium be added to a mixture of copper and nickel, unless there is plenty of room in the crucible, because there is a great risk of having the metal flow over into the fire and become lost. Care must also be taken in adding alkaline metals, such as sodium, potassium, and the like, to lead or tin in experimental work, as they explode violently unless they are in a very powerful carbon atmosphere—coal-gas, for instance—and as lead, tin, and other metals having a low fusing point make worse burns than iron or steel, the necessity for care is very apparent.

In conclusion it may be well to point out that when dealing with molten metal a bottle of pure raw linseed oil should always be available, as well as some white cotton thread waste or coarse lint, and if one unfortunately gets a splash of metal, the oil should be poured on freely. "Carron" oil—oil and limewater—is not so good for metal burns as pure linseed oil, according to the writer's experience. A great deal depends on condition, however, for while a heavy drinker, especially a spirit drinker, will have trouble with burns, a moderate man will find them dry up and heal without any application. The writer never worries about a few burns from molten iron or steel unless they are extensive, as they dry up very quickly; but a lead burn takes a long time to heal.—*English Mechanic*.

To obtain practically pure argon the following operation is carried out: The impure argon gas is passed from the cylinder through a tube of Jena glass containing 45 grammes of lime and magnesium mixture. It then passes through a second tube containing four troughs of nickel, in which are placed three or four grammes of metallic calcium in small pieces. Two mercury pumps are connected to the apparatus by a three-way cock. The first pump serves to produce an initial vacuum in the apparatus, and the second causes the circulation of the gas in the tubes, which are heated to low redness. The small quantities of nitrogen and hydrogen are retained by the calcium and the argon comes off in a practically pure state.

The preservation of creosoted piles is very striking. Some of those driven in 1876 as piers for iron bridges in the neighborhood of New Orleans are today in perfect condition, whereas the metal bridges which they support have now to be renewed.

HANDY HINTS FOR AMATEURS.

Contributions are solicited for this department, and for each accepted article the sender will be given the choice of any one-subscription premium from our premium offers.

ATTACHMENTS FOR LATHE.

F. H. JACKSON.

Chuck for Lathe.

The chuck shown will be handy for holding nuts to face off, or for that matter, a great variety of pieces to be turned. *A* can be made of cast iron with projection *B* to screw on spindle, or it can be made of wagon tire steel $\frac{3}{8} \times 2\frac{1}{2}$ " and a hexagon nut, *B*, welded on and afterward topped out to fit on lathe spindle. The sliding pieces, *C*, fit over edge of *A*, which is beveled and has a set screw, *D*, in one end to clamp to plate. The screws,

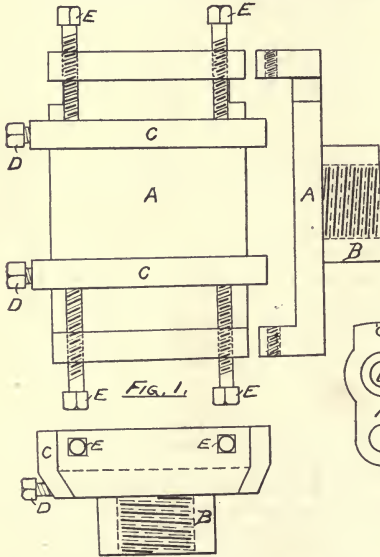

pipe size and should have a piece of round iron, *B* screwed in tight to be held in a self-centering chuck. All chucks should have same size at *C*, but the opening at *A* should be for $1\frac{1}{2}$, 2, $2\frac{1}{2}$ and 3" pipe size.

Drill Rest for Tail Spindle.

The holder *A* fits on a blank centre by hole *B*. Plate "*C*" is made with holes *D* of different sizes in this plate, as follows: $\frac{1}{8}$, $\frac{1}{4}$, $\frac{3}{8}$, $\frac{1}{2}$, $\frac{3}{4}$, and $\frac{1}{2}$ ". The plate is held by a spring pin, *E*, which enters a small hole in back of plate directly over hole opposite end of tail spindle. The construction of the plate is so plain that

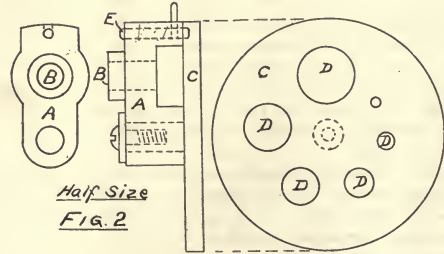
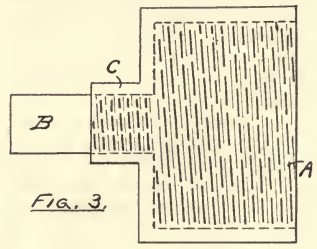

E, (of which there should be several lengths) give the grip which holds the piece to be turned. It is advised to use screws *E* as short as possible, so that they will project no further than necessary, as they are great "knuckle dusters."

A chuck of this kind has been in use several years and has been found very handy on many occasions, and is well worth the time consumed in making.

Chucks Made From Pipe Reducers.

These chucks are very handy, as a piece of wood can be screwed into the socket at *A* and turned to hold any special piece to be turned. The part *C* is for $\frac{3}{8}$ "

it hardly needs any description. This size is suitable for lathes from 6 to 9" swing. The entire plate is made of cast iron. Care should be used in forcing the holder *A* on the blank centre at *B*, as it is held by friction.

Water is nearly incompressible, but for all that, says Professor Toit, if the water in the ocean were not compressed as it is by its own weight, the level of the sea would be 116 feet higher than it is at present. In that case, 2,000,000 square miles of what is at present dry land would be submerged.

PHOTOGRAPHY.

PRINTING FRAME.

FRANCIS L. BAIN.

The frame described below will undoubtedly fill a long-felt want in the workroom of many amateurs, particularly those interested in photography, as it can be made quite cheaply. For those who prefer lightness rather than strength and long service in a printing frame, it is suggested that whitewood be used, while those who do not object to a little extra weight will find that cherry will far out-wear whitewood and give much better satisfaction generally.

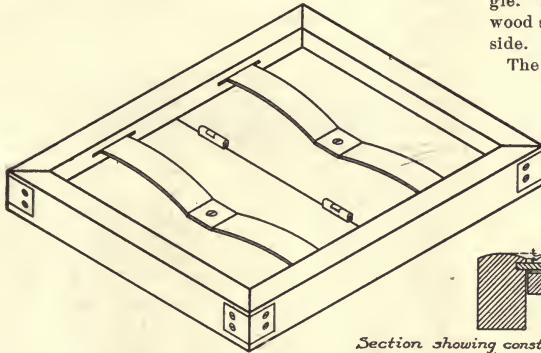

Section showing construction.

The following materials will be needed, and in each case the measurements as given represent the *finished size* of the particular article referred to:

Sides—2 pieces kiln dried cherry 17½" long, 2" wide, 1¼" thick. Ends—2 pieces kiln dried cherry, 14½" long, 2" wide, 1¼" thick. Backs—2 pieces kiln dried white pine, 11½" long, 7-16" wide, ½" thick; 2 pieces felt, 11½" long, 7-16" wide, 1-16" thick; 1 piece glass 15½" long, 12½" wide, 3-16" thick. Springs—2 pieces spring brass 12½" long, 1½" wide, 1-16" thick; 4 pieces sheet steel 3" long, 1½" wide, 1-32" thick; 2 brass wood screws, round head, ½", No. 9; 8 bright iron wood screws, flat head, 1", No. 7; 2 brass hinges 1½" long, 1½" wide, when open; 8 brass wood screws, flat head (to fit hinges) ¾" long.

After the four pieces of cherry have been planed to the required size, one broad surface, or side of each piece, should be numbered 1, and one of the narrow sides adjacent to this (known as the "joint side") should be numbered 2, then gauge a line on each No. 1 side which shall be ¼" from and parallel with, side No. 2; following this with another gauged line 3-16" beyond the first one (or 7-16" "from the joint side"). The space between these two lines should next be rab-

bed out to a depth of ¼", either on a circular saw or with a small chisel or router-plane, thus forming a groove into which the glass is to be fitted. The No. 2 edge of each piece is now to be rounded off with plane and sandpapered, the rounding extending down on either side to a distance of ⅜", as shown in the sectional view. The frame is now ready to be mitred together, and if it is possible to get access to a mitre box the resulting cuts will be far more accurate than they otherwise would be. The four pieces of sheet steel, 3x 1½x1-32", should now be bent to form perfect right angle braces, and two countersunk holes bored in each leg about 1" from and parallel with the corner of the angle. These holes should be bored for the 1" No. 7 wood screws, and the counters should be on the outside.

The two long sides of the frame should now have two grooves in each, on the No. 1 side, to receive the ends of the brass springs. The measurements are as follows: Gauge a line on sides No. 1 just 1-16" from the No. 2 edge, and another parallel line ⅜" from the first one, then measure in 3" from each extreme end and again measure 4" further in from each of the marks just made, thus forming two spaces 4" long by ⅜" wide. Rabbet these out with a small chisel to a depth of ⅜", then thoroughly sandpaper each piece,

using Nor 1½ and 0 sandpaper, not, however, touching the mitred ends with sandpaper, as jointed surfaces intended to be brought together should never be sandpapered. The plate of glass should now be inserted into the rabbet of all four sides, the frame clamped closely together without the necessity of using nails, dowels or glue.

The ½ pine "backs" should next be finished as per schedule, and to these should be glued the pieces of felt, then the two pieces should be hinged together with just the joints of the hinges showing, as per illustration. The distance of hinges from sides of frame is entirely a matter of judgement, depending upon the size of the frame.

The brass springs are next in order, to be made as follows: Measure in 5½" from each end and square a line across the width of the piece. From these lines bend the ends of the piece upward until, when the central flat space (which will be 1½" square) is held firmly on the bench, each end will be 1¼" above the surface of the bench. Then bore a hole through the exact centre of the 1½" square resting surface for a ½" No. 9 screw, and screw in place, allowing just enough "play" for the springs to be swung in and out of the

slots freely. If the tension on these springs is too great or too little, it can be remedied by increasing the height of the bend. This bending, by the way, should be done straight, not curved in any way.

With this, as with other articles of this nature, the matter of size is governed entirely by the character of the work for which the frame is to be used, but for general use the size mentioned here, 12x15" inside, is very desirable. If desired, one or two coats of white shellac may be applied to the frame, though with cherry one coat of oil is just as useful.

REMOVING AIR BUBBLES.

Air bubbles, says the "Amateur Photographers" are a frequent source of misfortune to the beginner chiefly because he does not know how to control them. They are especially difficult to manage when developing the larger sizes of gaslight papers, a large air bell getting beneath the print, and by preventing the developer from flooding the whole surface, causing the image to appear unevenly. Air bubbles are, to a certain extent, prevented by immersing the printing paper in water prior to sweeping on the developer, but should the water be drawn straight from an ordinary tap, it will only add more trouble, owing to the numerous air bubbles it will itself contain. Should a large bubble of air get imprisoned under the print, it is quite useless to attempt to get rid of it by dabbing the print with the finger, such procedure only risking the likelihood of marks or scratches. The photograph should be at once lifted up by one corner right out of the developer, so allowing the air to escape. Upon letting the print sink down into the developer again, it will be found to lie quite flat, and no risk is run to damaging the film or developing unevenly.

POSING THE HANDS,

The pose of the hands is a favorite topic in photographic journals. It has recently been again pointed out that one of the greatest difficulties in posing hands has been the nervous consciousness of the sitter; but this fact is, fortunately, becoming a thing of the past. The greatest troubles nowadays are the slight exaggeration of the short focus lens, and the belief in many minds that hands are smaller than they really are. Do not (says a writer in *Wilson's Photographic Magazine*) let the sitter hear a word about her hand; try to let her forget them. Do not let the hands be placed symmetrically, so that the head looks like the apex of an isosceles triangle. Hands look more prominent on dark dresses than on light ones. A hand may be partly hidden by the folds of a dress, or its size may be apparently reduced by placing it sideways to the camera. If it is a natural pose, a hand supporting a cheek or chin looks well. If the fingers

are relaxed the hand looks smaller and more natural than when the fingers are stiff. Treat each pair of hands on their merits, usually by leaving them to the natural unconsciousness of the sitter, and the difficulties of posing the hands will in a great measure disappear.

BOOKS RECEIVED.

ELECTRICAL DESIGNS. Various authors. American Electrician Co., New York, 9x6; 262 pp. \$2.00.

There is probably no book published which would be of greater interest to advanced amateurs. The construction of 34 different pieces of electrical apparatus are fully described, with ample illustrations to make clear the text. Ten motors, five dynamos, galvanometers, coils and similar machines are included. It should be found in the library of every amateur interested in electricity.

FREE HAND LETTERING. Victor T. Wilson, M. E. John Wiley & Sons, New York, 9x5½; 95 pp, 23 plates. \$1.00.

Draftsmen, as a rule, do not give sufficient attention to lettering, yet nothing adds so much to the appearance of drawings as suitable lettering. The book before us treats of the design and work of lettering in a complete and analytical manner, with the result that anyone studying the same should have no difficulty in becoming proficient. The plates giving illustrations of various styles of lettering are exceptionally well done. Teachers in manual training schools, as well as draftsmen generally, will find the book of great value.

WIRELESS TELEGRAPHY. Charles Henry Sewall. De Van Nostrand Co., New York. 8½x5½; 230 pp. \$2.00.

A comprehensive view of wireless telegraphy, its history, principles, systems and possibilities in theory and practice are herein presented with numerous illustrations. Those who are interested in wireless telegraphy and desirous of learning the technical features of the various systems will find the book of much value. The various parts of apparatus are described in detail, together with much supplementary information.

TECHNOLOGICAL AND SCIENTIFIC DICTIONARY. Parts I. and II. George Newnes, Ltd., London, England. 64 pp. each. Paper, 40 cents.

The rapid progress made in recent years in scientific and technical lines have been productive of so many new words and expressions that this dictionary should be of special value to libraries, schools, and those interested in general scientific matter. A very able staff of editors has charge of the composition and editing of the work. The typographical arrangement is excellent.

METHODS OF CONTROL IN PICTORIAL PHOTOGRAPHY. A. Horseley Hinton. No. 61 Photo-Miniature. Tennant & Ward, New York.

The mention of the author's name is all that is needed to assure readers of its value. It has much of interest to readers, both amateur and professional.

JUNIOR DEPARTMENT

For the Instruction and Information of Younger Readers.

ELEMENTARY MECHANICS.

J. A. COOLIDGE.

VI. The Screw.

Rivalling the lever both in frequency of use and in value is the *Screw*, a machine consisting of a cylinder or cone (See Fig. 16 and 17) with a "thread" or narrow inclined plane wound in spiral form along its length like a spiral staircase on a small scale. Unless it is a common screw of conical shape it is fitted into a nut or receptacle of some shape in which has been made a counter thread or hollow spiral to receive its thread.

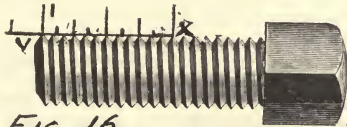

We shall confine our attention to cylindrical screws, although what we shall say will apply in general to the common screw. In machines, such as the jack screw, the power is applied at the end of a lever and causes the screw to pass through its nut, pushing before it the weight to be lifted or the resistance to be overcome. The common law of machines:—"Power, multiplied by the space through which the power acts,

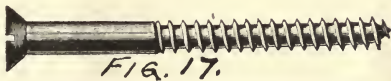

equals the weight multiplied by the space through which the weight moves," will apply, of course, to the screw, although friction will make it seem false.

EXPERIMENT 13.

Take a cylindrical screw (see Fig. 16) of rather coarse thread; rub a piece of graphite or soft pencil along one side and then lay it upon a piece of unglazed paper. Press it hard upon the paper and the thread will make a series of short marks corresponding to the ridges in the figure. Measure from one of these marks a space an inch long. (See XV Fig. 16.) Count the number of spaces in this line and you will have the number of threads to the inch. Do the same with several screws of different sizes, including one or two tapering screws.

For every complete turn of the screw it moves through the nut the space between two threads. If, therefore, there are 12 spaces to the inch the space the weight moves for one turn of the screw is 1-12". Now,

if the screw be that of a carpenter's vise and we apply a force on the handles 14" from the centre of the screw, the power space will be a circle whose radius is 14", i. e., 14×2×3 1-7, or 88". If, in the law of machines, P.

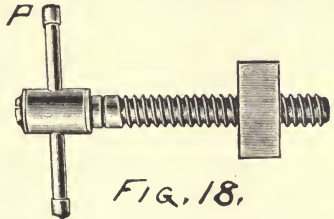

× P. space = wt. × wt. space, we supply the distance 1-12" and 88" and consider one force equal to 30 pounds, we shall have 30×88 = wt. × 1-12. This will give us 1-12 of the wt., 2640 or a total value of 31,680 pound, an almost incredible amount. But, as is often the case, $\frac{1}{2}$ or more of the force is lost by friction. Even with this loss we have an actual result of 7920 pounds resulting from a force of only 30 pounds.

EXPERIMENT 14.

Take the wooden screw and nut from a carpenter's bench (See Fig 18), [half of a carpenter's clamp or even a large iron bolt and nut may be used if the first is not available], find the number of threads to the inch for wt. space, and measure the length of this handle from the centre of the screw to the point P. At P. attach the spring balance used in former experiments. Bore a small hole in the lower end of the screw and turn in a screw eye. On the screw eye hang a weight W. Fasten the nut firmly so that as the power is applied at P. the weight shall be raised.

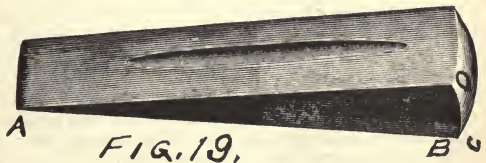

Using the law P. × P. space = wt. × wt. space, supply all the values except the power. Wt. space equals the distance between two threads of the screw. P. space equals 2×3 1-7× the length of the handle, i. e., if the length, AP, in Fig. 16, is 14" it will be 2×3 1-7×14, or 88". With a known weight W, say eight pounds or more, calculate what the power should be. Now pull on the balance and make a number of trials until you have obtained a constant value for P. Should it be

four times as large as the value calculated, do not be surprised, as this shows the exceedingly large amount of friction. You may say, of what use is the screw when $\frac{1}{4}$ of the force is lost? If you will recall our study on friction you will remember that friction is a great help as well as a hindrance, and here we can see the need of this friction. Suppose we are clamping a piece of elastic wood in a vise and that, as soon as this wood is pressed between the jaws of the vise the elastic wood pushes back and the jaws are pushed as far open as before. As it is now, the friction of the screw in its nut prevents the vise from opening, but if that did not hold, some other contrivance would be necessary to prevent slipping.

If the heavy weight resting on a "jack" exerted a downward force great enough to overcome the friction of the screw, the screw would turn backward and the weight fall slowly. We can see the value of what really hinders the motion of the power.

Of the many screws in use, especially the larger ones, perhaps those that will impress us as being most valuable are those used in vises, carpenters, clamps, letter presses, presses used for various purposes, wagon jacks and, most of all, the large jacks put under a house to raise it. These, with the many screws and bolts used for various purposes, will convince us of the great value of the screw.

THE WEDGE.

Although a machine less used than any of the others, a series of articles would be incomplete without a brief mention of the wedge. It is really an inclined plane, or a double inclined plane with the bases joined so that both long surfaces are oblique to the edge of the height. See Fig. 19. The power, instead of pushing the weight steadily up the plane, by quick, successive blows drives the wedge under the weight, or, as in splitting wood, between the portions to be moved or separated. Because of the method of applying the force, *i. e.*, by quick, repeated blows, as well as on account of the great friction, any simple experiments with the wedge are out of the question. The law of the wedge is, as in all machines, $P \times P. \text{ space} = wt. \times wt. \text{ space}$, and, as seen in Fig. 19., if AB is 12" and DC 2" with a force of 200 pounds; $300 \times 12 = 2 \times wt.$, therefore the weight equals 1,800 pounds. Much of this will be lost by friction, however, but notwithstanding the loss, much is gained. The wedge is used in launching ships, in raising buildings or parts of buildings for short distances, in laying floors and splitting wood. It can be used when the other machines cannot be applied, and proves a very valuable machine.

TRADE NOTES.

A cheap, portable, yet strong and accurate pair of Pocket Compasses has long been the wish of all whose occupation involves the use of drawing instruments, such as builders, draftsmen, mechanics, engineers, sur-

veyors, architects, students, etc. Heretofore all pocket compasses were either too cheap to be specially accurate and durable, or so high in price as to forbid their general use.



Kolesch & Co., 138 Fulton St., New York, have lately placed on the market an instrument which overcomes these drawbacks while it embodies strength, accuracy, durability. The "Indispensable" Combination Drawing Set, as shown in illustration, consists of a pair of dividers, pencil compasses and pen compasses in one piece. As can be seen in the cut, the pen and pencil point are each made integral with one of the steel points, and each one of these pieces is firmly riveted to one of the legs; it is reversible, so that either the steel point or the pen and pencil point can quickly be brought down on the drawing surface. By this method there are no loose parts or screws, which might get lost, while the instrument is readily adjusted for use. The instrument is made of strong steel bent and braced to make it as rigid as possible. The points are very strong and of an improved style so that they will never lose their adjustment. When closed the instrument is very compact and weighs only $\frac{1}{4}$ oz. The instrument is nicely finished and nickel plated.

It is also furnished in a neat, strong pocket case which also holds a good 5" Ruling Pen. A descriptive circular will be sent on application. The price is 75 cents without drawing pen; \$1.25 with pen in pocket case.

The Saw Bench sold by the Frasse Co., 38 Cortland St., New York, is a very necessary tool in all shops where the ripping or sawing of wood is of much account. It is furnished both with foot power and hand crank, and provision is made for cutting thick wood. Two saws are provided for different operations, also an emery wheel, which can be employed for sharpening chisels, plane irons, skates and general grinding. The purchase of one of these machines by a carpenter enabled him to fit a number of doors in a hotel contract that he had taken, and he stated that he was able to do more than fifty times the work than if he had used a hand saw. A descriptive circular will be sent upon request.

Amateur Electricians who have purchased secondary windings from the New England Coil Winding Co. are much pleased with the construction and workings of these coils. They are just the thing for amateurs who are interested in electrical experiments requiring coils.

By treating zinc with aluminum in various proportions, nine different well-defined alloys have been obtained.

AMATEUR WORK

A MONTHLY MAGAZINE OF THE USEFUL ARTS AND SCIENCES

Vol. III. No. 10.

BOSTON, AUGUST, 1904.

One Dollar a Year.

A TELEGRAPH TRANSMITTER.

FREDERICK A. DRAPER.

Those interested in wireless telegraphy experiments who have not learned the Morse code, and yet desire to transmit messages, can do so by means of the simple arrangement here described, which closely resembles the original device used by Prof. Morse in the early days of telegraphy.

A frame made of plain picture-frame moulding should be purchased. The inside measurements should be about 6x8 in. A piece of sheet brass is then cut to fit inside the frame, in the same way that a piece of glass would be fitted for a picture. Also a piece of 4-ply white Bristol cardboard of the same size is cut, and then on one surface marked lightly with a pencil to show the inside edge of the frame.

Across the cardboard in the longer dimension draw lines with India ink, the first one $\frac{3}{8}$ in. from the line showing the edge of the frame, the second one $1\frac{1}{8}$ in. from the first line, then $\frac{3}{8}$ in. followed by a $1\frac{1}{8}$ in. space, etc., marking off four spaces of each width. With the first narrow space at the top, mark lightly with a pencil a vertical line, $\frac{1}{2}$ in. from the line showing the left edge of the frame, and nine other lines $1\frac{3}{8}$ in. apart. On either side of these ten lines make other pencil lines $\frac{1}{8}$ in. away, forming spaces $\frac{1}{4}$ in. wide.

Directly over the centre lines just mentioned and in the $\frac{3}{8}$ in. space across the sheet, mark in India ink the figures and letters as shown in the illustration, this being a typewriter arrangement to avoid the excessive movements that would be required by an alphabetical one. The lettering should be heavy that each character may be easily

read. Holes are then cut through the cardboard under each character with a sharp knife, the sizes varying to represent the dots and dashes. The horizontal ends of the holes should be on the lines on either side of the centre line under the letter, making them uniformly $\frac{1}{4}$ in. long. The vertical

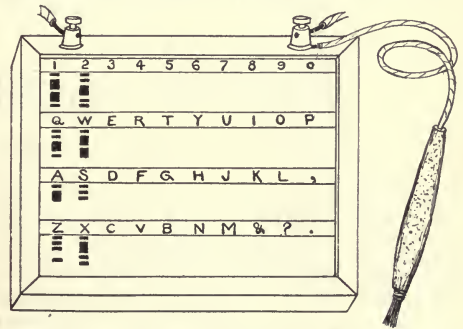

length must be carefully marked out to a uniform scale, that for a dot being of unit length, and a unit of about $\frac{3}{8}$ in. will, on the longer letters, require all the available space. The spacing should be marked out as follows:

Signal.

Dot	1 unit.
Dash	3 units.
Long dash	5 units.
Very long dash	7 units.
Space in letters	1 unit.
Space in spaced letters	3 units.
Space between letters	3 units.

Also, when using the transmitter, the spacing between words should be a time interval repre-

sented by six units. To illustrate the unit spacing, take figure 1 at the left end of the top row comprising dot, dash, dash, dot:—for the dot cut a hole $\frac{3}{8}$ in. long; $\frac{3}{8}$ in. below this hole cut another for the dash $\frac{3}{8}$ in. long; $\frac{3}{8}$ in. below this cut another for the second dash of the same length, and $\frac{3}{8}$ in. below this a hole $\frac{3}{8}$ in. long for the second dot. The top edge of the upper hole of each character should be but on the cross lines under each character. When all the holes have been cut a stencil is formed which is then given a coat of spirit shellac on each side, that on the under side being put on last and as quickly as possible, so that, while the shellac is still moist, the stencil can be placed upon the sheet of brass, smoothed down to get a firm contact, and allowed to dry in position. In a short time the stencil will be found firmly united to the brass, which may be seen through the holes. Should any shellac work out into the holes it should be removed with the point of a knife. The stencil and plate are then put in the frame and fastened the same

as for a picture.

Two binding posts are now mounted on the upper edge of the frame, the base of the one on the left being connected with the brass plate, that on the right with a piece of flexible conductor, the other end of which is put through a cork pen-holder with about one inch of the conductor protruding at the lower end. Enough of the wire from a piece of the conductor is cut into short lengths and formed into a brush at the end of the pen-holder, by winding a number of turns of wire around the base of the brush, and the transmitter is complete.

To use it, the line wires are connected to the binding posts, the brush is carried across the holes under the characters with slow, steady movements, the circuit being completed when on the brass and broken by the cardboard strips between the holes. A little practice will enable anyone to send an accurately spaced message. A description of a tape receiver operated by clock-work will be given at an early date.

WIRELESS TELEGRAPH APPARATUS.

HOWARD W. RICE.

Appreciating the interest taken in electrical subjects by the readers of *AMATEUR WORK*, especially in relation to signalling through space by means of high potential oscillations, the writer, whose working hours during the past three years have been devoted to the designing of apparatus for the highest of induced voltages, takes pleasure

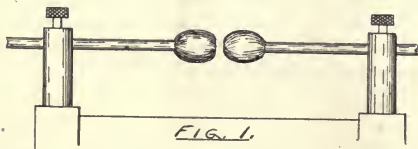

in contributing a few personal observations bearing directly upon the sending and receiving ends of experimental wireless stations, such as an amateur would use in connection with a spark coil of moderate size at the sending end.

Without committing myself to any one of several good systems now on the market, one cannot

but be in sympathy with the sending equipments that in personal tests have shown up the best. For example, some wireless electricians now in the employ of private and governmental institutions favor one "dispenser" because of the noiseless operation, yet equally well posted men would prefer results attending the racket of more vigorous oscillations at the spark gap.

Let us consider in this article that the amateur possesses an induction coil giving about an inch spark or over when operated by a few cells of battery. The spark gap is made of two brass pieces shaped as in Fig. 1 and separated less than $\frac{1}{8}$ of an inch.

Fig. 2 shows the transmitting circuit, *A* being a Leyden jar constructed of a pint battery jar coated inside and out in the usual way with tin foil. The circuit, *X*, as marked by heavy lines, consists of a bundle of soft iron wires, 6 in. long and $\frac{3}{8}$ in. in diameter, on which is wound the entire length, two layers of No. 12 copper wire,

heavily insulated with three or more coatings of cotton thread and the layers separated by a layer of thin mica. Over this primary is wound two more layers of mica and five layers of No. 16 cot-

of thin paper between each layer. This coil may also be immersed in oil.

The coherer herewith illustrated, Fig. 4, is intended for use with a telephone receiver and not with a relay and sounder circuit. As many readers would prefer to experiment with different types of coherers, several types will be illustrated in another article. This type, however, will give excellent results.

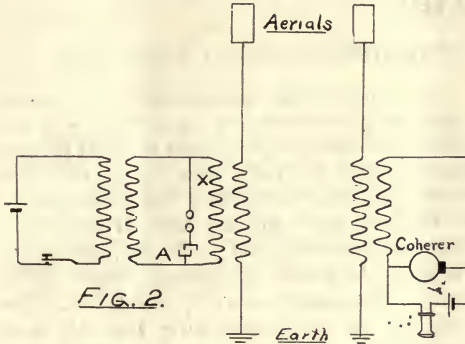

FIG. 2.

ton covered wire, each layer being separated by a layer of mica, and the wire wound not too snugly together in turns. This coil is to convert the waves that oscillate at the spark gap to a still higher intensity, and the entire windings must be kept in a jar filled with parafine or similar insulating oil.

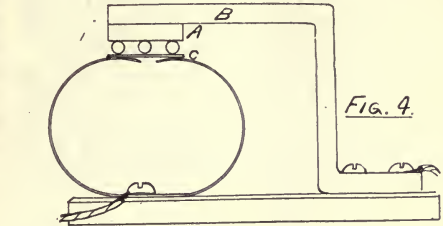

FIG. 4.

The spring is a flexible clock spring, bent in the form of a hoop three inches in diameter. *A* is a block of polished carbon, *B* is a metal support, *C* is a flat disc of aluminum. Between the two are placed three polished steel balls such as are used in bicycle bearings. The pressure of the spring keeps the balls in place. This coherer, if properly constructed, responds in buzzes, and the length of the buzz is regulated by the contact made at the sounding key. It has operated three miles with perfect success. Doubtless much greater distance can be covered under suitable conditions of ground and aerial.

The foregoing set commends itself because of its simplicity of construction and is worthy the attention of all amateurs.

More opportunities for the alternator follow in the wake of the steam turbine. *Power* says that a curious side issue from the increasing use of steam dynamos is that the dynamo with its commutator is being discredited, whereas, an alternator is, if anything, easier to design for high speed than it is for low speed. Many engineers contend that the commutator is quite impossible for large steam turbines, and it appears that if direct current is required from a large power station in which steam turbines are employed, it is necessary, or at any rate advisable, to instal turbo-alternators and rotary converters. The alternators would be wound for low voltage to avoid the step-down transformers.

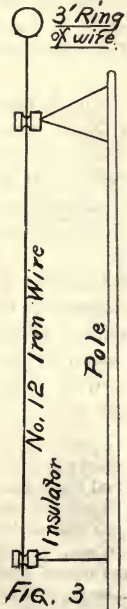

FIG. 3.

layers, and four turns of paper between primary and secondary. The secondary consists of six layers of 36 D. C. C. wire separated by one sheet

TELEPHONE CIRCUITS AND WIRING.

ARTHUR H. BELL.

An Intercommunicating System.

In manufacturing establishments, schools, apartment houses and hotels, the intercommunicating telephone furnishes the most direct means of conversation between manager and workrooms, principals and subordinates, tenants and landlords.

In the installation of the equipment here described, particular attention is devoted to simplifying the telephone sets themselves, dispensing with induction coils and magneto signaling apparatus, and all strap keys and complicated hook contacts.

In considering the arrangement of line wires connecting the instruments together we will undertake a three party equipment as would be used between three floors of a factory or private office, work room and stock room of any establishment.

We will install the full length of the circuit, from the first telephone to the last, one pair of wires to be known as "battery" leads. These wires will terminate on a strip at each end. Also will be run three more wires over this same course. It will be advisable, if possible, to use different colored wires (annunciator) so that any one wire can be singled out for testing or connection of wires. This is not difficult to arrange, as annunciator wire comes in various colors, and the exact amount of wire of each color to be used may be estimated by the length of the battery leads previously installed.

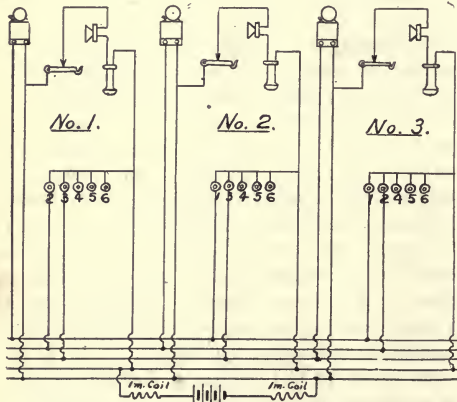

Fig. 8 illustrates one telephone set as used with this system. First there is a vibrating bell or buzzer of a type usually sold by dealers for door bell and general signalling. A pair of wires are connected with the bell binding posts. The terminals of these wires are to be connected later on to the main line wires.

One side of the bell is directly connected with an automatic hook which on upward contact, that is, when the receiver is removed from the hook, puts the transmitter and the receiver in series circuit. The other side of the receiver takes a certain point of connection on the main line wiring. A series of push buttons is arranged, as shown in the sketch, for signalling purposes.

It will be noticed in the diagram, Fig. 8, that one wire leading from the bell takes No. 5 wire, *i. e.*, the lower battery lead and the other wire of the bells takes the same number of conductor as is its station number. For example, bell wire for No. 1 station takes No. 1; 2 takes No. 2 conductor, etc.

One side of a push button takes that number of conductor as is the number of the station it is to ring, and the other side or the push button, which is a common wire, takes the wire coming from the receiver, which takes the fourth wire in all cases.

A valuable anthracite discovery has taken place on the boundaries of the Canadian National Park near Banff. The seam is already known to run 10 miles; it has a solid thickness of 10 ft., and an analysis shows the coal to contain from 75 to 80 per cent of carbon. In the Pennsylvania anthracite the carbon runs from 80 to 88 per cent. In the face of such finds, how is it possible for certain croakers to fix a limit to the world's fuel store and prophesy the speedy exhaustion of the coal-fields? There may be ten times as much coal yet to be discovered as they at present have any knowledge of.

HANDY HINTS FOR AMATEURS.

Contributions are solicited for this department, and for each accepted article the sender will be given the choice of any one-subscription premium from our premium offers.

A HANDY COMBINATION.

R. G. GRISWOLD.

The enclosed sketch shows a very handy combination for the amateur's shop which takes up little room and has a number of points to recommend it. In the first place, the three tools are operated from one driving wheel, the operator standing in any position necessary to properly execute the work in hand.

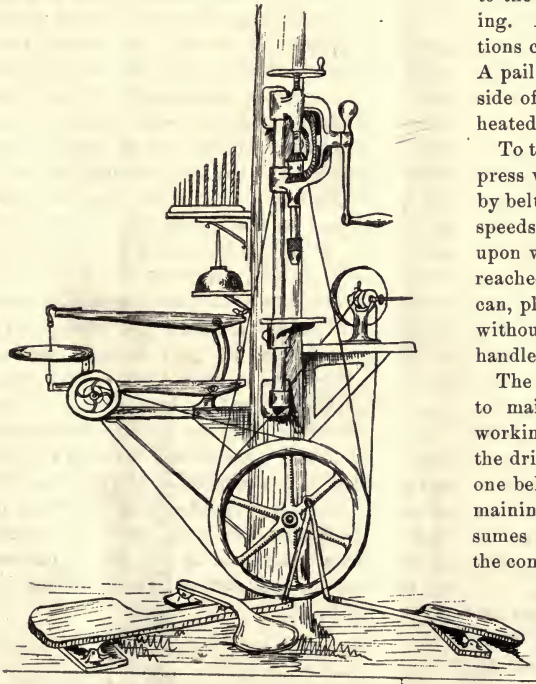

To the left is shown a scroll or jig saw, mounted on a rigid arm and having a brace running from a wall behind to prevent vibration while cutting. The table can be tilted to cut bevels. The treadle which drives the fly wheel when the saw is in use is of such length that the operator does not

have to reach out with his foot, the length making the angular motion of the foot less and not so tiring. The tread is made wide, to accommodate both feet when sitting for extensive operations or for either foot while standing, without shifting the position of the body.

To the right is shown a grinding and polishing attachment, operated by the same driving wheel. This grinder accommodates several sizes of wheels and a series of buffs and brushes can be attached to the spindle opposite the wheels used for grinding. A rate of ten or twelve hundred revolutions can be readily maintained without fatigue. A pail of water should hang on the right hand side of the grinding shelf to dip tools into when heated by grinding.

To the front of the post is attached a hand drill press which has also an attachment for driving by belt for the small drills which require high speeds. To the left of the drill is shown a shelf upon which a set of drills can be kept and easily reached when needed. Directly beneath is an oil can, placed on the left so that it may be used without taking the right hand from the drill press handle.

The driving wheel should be made very heavy to maintain a steady speed when the tools are working. While all three belts are shown on the driving wheel at once, it is only intended that one belt at a time shall be used, as to run the remaining tools, while working on one, merely consumes power. Three treadles are provided for the convenience of the operator, the one for operating the drill press being placed on top of the one to the left, thus making a connecting rod unnecessary. When not in use it is held up by small wire hook at such a distance above the under treadle that they will not strike. The three attachments are thus compactly mounted, have a solid foundation, and are all operated from one wheel. The saving of valuable space in the amateur's shop is thus made possible, while the value of none of the tools is impaired in the slightest.

A BENCH GRINDER.

B. R. WICKS.

A small emery wheel about your workshop, house or barn can be made to do a large amount of useful work, such as grinding knives, shears, axes, chisels, plane irons, spoke shave irons, etc., and to the amateur mechanic a tool of this kind will be found to be one of the most useful to be found in his workshop, as it can be used for grinding off uneven places on castings when good files would be spoiled; also for grinding lathe tools, drills, counter bores, reames, cutters, and a hundred other uses that present themselves in the course of his work from time to time. No amateur who is engaged in making models of steam or gas engines, electric motors or dynamos, can afford to be without one, as the time expended in making it will pay for itself a hundred times over.

The grinder to be described is a six-inch bench grinder, equipped with all the handy fixings to be found in a modern machine. This grinder can be operated by foot power to very good advantage, or by a countreshaft when motive power is to be had. This grinder is composed of five iron castings: one frame, *A*; one driving pulley, *C*; two wheel flanges, *D* and one tool rest, *H*. The spindle *B*, rest No. 1, *E*, No. 2 *F*, and tool rest spindle *G*, are made from steel. The set screws are all standard thread and are cut off to figures given on detail drawing and $\frac{5}{32}$ in. rods driven through the heads. The two construction drawings show the parts of this grinder in their respective places, and the details below show the parts that are required to construct the grinder, with dimensions and name of parts and material used from which to make them.

In beginning the tooling on the castings the frame or stand, *A*, will first be dealt with. First find the centre of the $\frac{1}{2}$ in. boss of the bearing barrel with a pair of hermaphrodite calipers, and make a light prick punch when the centre has been located. Rub the bottom of the casting with chalk, and set the castings on a surface plate. Set the bearing square both ways with a square, and the needle of the surface gauge or scratch block exactly in the centre of the prick

punch mark in the $\frac{1}{2}$ in. boss, and strike a line across the bottom of the casting; this will give one centre line. To find the other centre, set the casting square with the inside of the base and set the gauge needle as before to the prick punch mark and strike another line across the bottom which will give the exact centre of the casting both ways. Centre both the boss and bottom with a small drill, and countersink and face off the bottom of the casting between centres.

The $\frac{1}{8}$ in. hole for the spindle, *B*, is now to be drilled and reamed. This operation can be done to very good advantage between centres in the lathe. Find the exact centre of the bearing barrel on each end with the hermaphrodite calipers make a fair size centre punch mark. Put a $\frac{5}{32}$ in. drill in the drill chuck, and with the tail stock centre in one punch mark, start the drill in the other punch mark. Drill in, feeding the drill slowly to a depth of about $1\frac{3}{8}$ in. Turn the casting around, end for end, and drill in until the two holes meet. With care in drilling these holes will come exactly in line. Remove the $\frac{5}{32}$ in. drill from the chuck, and in its place use a $\frac{1}{2}$ in. twist drill and drill as before. Then put through a $\frac{1}{4}$ in. drill and drill all the way through, reaming out with a lathe reamer about .002 smaller than $\frac{1}{8}$ in. and finish with a $\frac{1}{8}$ in. hand reamer.

Facing the two ends of the bearing can be done with a countrebore large enough to sweep $1\frac{1}{8}$ in. and provided with a $\frac{1}{16}$ in. pilot, or if the lathe will swing 8 inches a $\frac{1}{8}$ in. mandrel can be forced in and the ends faced off in the lathe. The length of the spindle bearing is $2\frac{1}{2}$ in. The $1\frac{1}{2}$ in. boss on the front of the casting forms a bearing for the rest No. 1, *E*.

Prof. John Milne has suggested that the displacement of the position of the earth's poles, which is of an irregular kind, and which can be traced to no known law, may be due to movements of the earth's crust, and that, therefore, the magnitude of the change in position of the poles might be expected to correspond in some way to the number and frequency of great earthquakes.

PATTERN MAKING FOR AMATEURS.

F. W. PUTNAM.

VI. Core Box for Small Gland, — Small Plunger, — Crank.

The core box for the gland is shown in Fig. 31, *A*. Round cores, like the one used for the plain cylinder, described in the July issue, are usually made in two part boxes, held together by dowel pins. For cores 3 in. or over in diameter, single half boxes are generally used. The core sand is packed in the box, wired, and turned out on the core plate. Two halves are made which, after

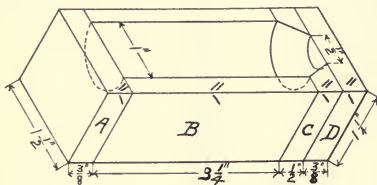

FIG. 31A. CORE BOX FOR GLAND.

being baked, are pasted together making a round core of just the required diameter. This kind of a box must be made exactly to size, otherwise the two halves will not make a core which will give the required hole in the casting. As the amateur pattern maker should learn to make boxes of this kind, we will make a half core box for the small gland described in the July issue.

Fig. 31, *A*, is an isometric drawing and shows clearly the four parts of the core box. The part *B* is to be made first from a block large enough to finish $3\frac{1}{2}$ in. long, $1\frac{1}{2}$ in. wide and $1\frac{1}{2}$ in. thick. The length of this block is figured directly from the pattern previously made. The bottom core print is 1 in. long, the pattern is $1\frac{1}{2}$ in. thick and the straight part of the upper core print is $\frac{1}{2}$ in. long, or a total of $1\frac{1}{2}$ in. A semicircular hole is to be cut out from the top surface of the block, approximating the curve with back saw cuts, and then working to as near the curve as possible with a gauge. This block is to be cut out in exactly the same manner as the core box for the plain cylinder, and no further directions should be necessary except to remind the amateur that the centre line of the top surface should first be

drawn before the half circles on the ends of the the block are marked out. The ends of the blocks, *B*, should be carefully squared from the top or face side, as should also the ends of the block, *C*, in order that perfect joints may be secured.

The block *C* is next to be made. This block should be just as thick as the length of the tapered part of the upper core prints on the pattern, in this case $1\frac{1}{2}$ in. The circles are marked on each end, the centres coming at the end of the centre lines on the top or face side. The curve may partly be cut out with the back saw, holding it at an angle, so as not to cut below the outline of the smaller circle. Next, work carefully down to the lines with a gouge, making sure that the bevel has been cut exactly straight. If this block is at all cross-grained, use a small, rat-tail file to finish the curves instead of the gouge. Having finally removed all ridges and made the surfaces smooth with sandpaper, glue and nail together the two blocks *B* and *C*, using $1\frac{1}{2}$ in. No. 16 wire brads. The two end pieces, *A* and *D*, are next planed up to $\frac{3}{8}$ in. thickness and glued and nailed on to the ends of the core box. The pattern and core box should now be placed together and cali-

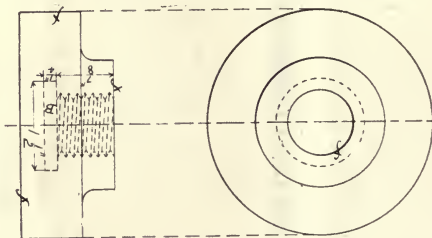

FIG. 32. SMALL PLUNGER.

pers applied from the outsides of the core prints in order to see if the length of the core box is correct. It is advisable to go over the entire pattern, testing every part for which measurements are given, and thus avoid any possibility of errors. I might say here that usually the out-

side of the core boxes, other than the two ends, may have as little work put upon them as possible, in many cases being left rough from the saw, the corners being worked off with a jack plane.

The following rule is usually followed in the making of small core boxes. The length of the core print is to be the same as the diameter. The upper core print is tapered half its length down to half the larger diameter. If the reader will notice the dimensions given for the core prints on the gland pattern, the above should be easily understood.

SMALL PLUNGER.

Fig. 32 shows a small plunger, the pattern for which is shown in Fig. 33. We will use a vertical core with this pattern, therefore *A* will be the top surface of the pattern, the arrow indicating the direction in which the pattern is withdrawn from the mold.

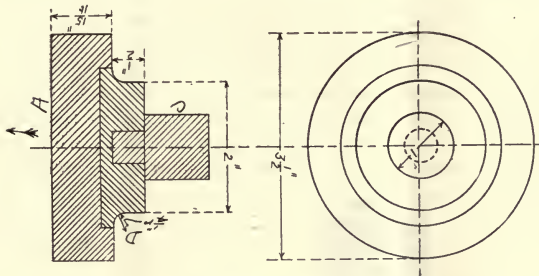

FIG. 33. PATTERN FOR SMALL PLUNGER.

The pattern may be turned from a solid block $3\frac{3}{4}$ in. square and $1\frac{1}{8}$ in. thick, or may be made from two pieces, as shown in the sectioned right end view of Fig. 33. A hole 1 in. in diameter and $\frac{1}{4}$ in. in length is to be cored out, and also a hollow chamber $1\frac{1}{2}$ in. in diameter and $\frac{1}{4}$ in. in length at the end of this hole. Fig. 32 shows the hollow chamber at *B* and also the hole which is to be threaded after the casting is made.

Fig. 34 shows the necessary core print for this pattern, and is placed as shown at *C*, Fig. 33. Only one core print is needed, as the core hole does not extend way through the casting.

No special directions should be necessary for turning this pattern if proper care is taken in turning the fillet at *D*, Fig. 33, and the necessary allowance for shrinkage and finish are made.

The half core box for this pattern is shown in Fig. 34, *A*. This is an isometric drawing and clearly shows the various parts of the core box. *A* and *D* are the end pieces. *B* is made first from a clear pine block large enough to finish $1\frac{7}{8}$ in.

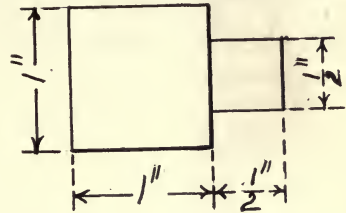

FIG. 34. CORE PRINT FOR PLUNGER.

long, $2\frac{1}{4}$ in. wide and $1\frac{1}{2}$ in. thick. The ends of the block must be accurately squared so that with pieces *A* and *C* perfect joints may be formed. The piece *C* had better be made from a stick $2\frac{1}{4}$ in.

long, $1\frac{1}{2}$ in. wide and $\frac{1}{4}$ in. thick. The grain of this piece will then be at right angles to the centre line of the core box and there will be no danger of the block splitting when it is nailed to *B*. This piece is cut to the outline of the hollow chamber *B*, Fig. 32, and therefore all surfaces must be made absolutely smooth and especial care taken in finishing the core box so that no core sand will adhere to this part of the core box when the cores are made. Both *B* and *C* of the core box should be carefully tested before being glued up.

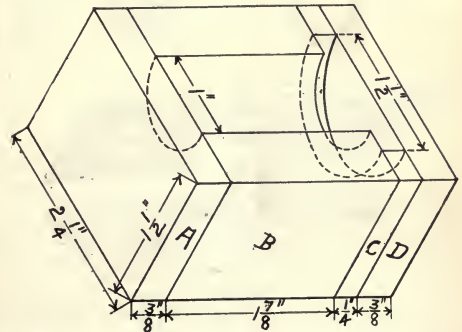

FIG. 34A. HALF CORE BOX FOR PLUNGER.

The ends are then to be fastened on and the core box finished as usual. The piece *B* must be made exactly the right length, otherwise the hol-

low chamber will not come at the required place in the casting.

SMALL ENGINE CRANK.

Fig. 35 shows the casting for a small engine crank, the pattern being shown in Fig. 36. The base *A*, which is semicircular at each end, is shaped from a board large enough to finish $\frac{1}{4}$ in.

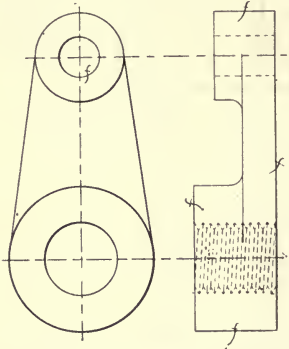

FIG. 35. SMALL ENGINE CRANK.

thick and $2\frac{1}{4}$ in. diameter at one end and tapering with a straight taper to the other end, which is $1\frac{3}{8}$ in. diameter. Do not finish quite to the lines until the collars have been fastened on, and be

necessary draft allowances being made at this time. The holes to receive the bottom core prints should be turned or bored out before the collars

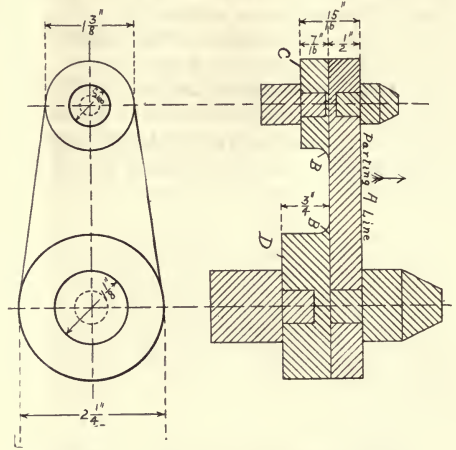
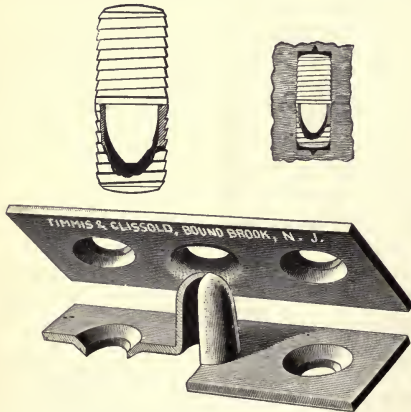
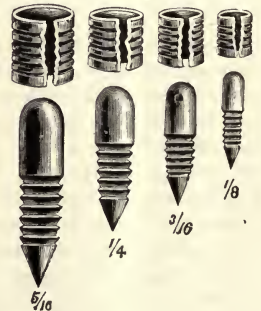

FIG. 36. PATTERN FOR ENGINE CRANK.

are removed from the lathe, care being taken not to strike the screw. The collar *C* is so thin that it may be found necessary to cut in with the sharpened end of the tang of a file in order not



G.



PEG AND TUBE, PLATE AND SHOULDER BRASS DOWELS.

sure to mark the circles on the top or face side of the base. The two collars *C* and *D*, Fig. 36, are turned on a screw centre, the fillets *B* being turned preferably as a part of each collar, the

to cut into the screw. The collars are to be glued and nailed to the base, after which the fillet on the outside half of each collar is to be removed carefully with a sharp chisel, care being

taken not to work against the grain. The edges of the base should now be worked down to the line, making a straight taper sufficient for draft, the parting line between cope and nowell coming at the top surface of the base.

The centre marks, which were made upon the top or face side of the base, are the centres of the holes which are to be bored to receive the ends of the core prints, which must and will come directly over the bottom core prints if directions

no further directions should be necessary.

The surfaces requiring finish are marked "f" as in previous patterns, and the necessary allowance for finish and for shrinkage and draft should be figured out before the pattern is commenced.

In the next article I shall describe the making of split patterns. These split patterns are, of course, dowelled, wood dowels being used for ordinary small patterns. Brass dowels are unquestionably far superior to wood dowels and are

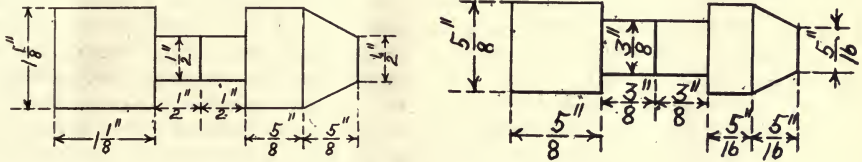

FIGS. 37 AND 37A. CORE PRINTS FOR ENGINE CRANK.

given here have been carefully followed. The top and bottom parts of the core prints should be glued at the same time and clamped tightly in place with an iron clamp or in a vise. The two core prints are shown in Fig. 37 and are turned from pieces of clear dry pine of a size sufficient to easily finish to the required dimensions.

Half core boxes are to be used, care being taken that the half circles are exactly the right size. As these are to be made in the same manner as the core box for the gland previously described,

much used for fine accurate work, their superiority lying in the fact that they are always perfect fitting and interchangeable. The brass dowels can be bought from 1/8 in. up to 5/16 in. in diameter. For large work brass plate dowels are very largely used, running from 2 in. to 2 1/2 in. in diameter. Through the courtesy of the Winkley Co., Hartford, Conn., and Timmens & Chissold, Bound Brook, N. J., I am able to show you the accompanying illustrations of peg and tube brass dowels, plate brass dowels and shoulder brass dowels.

PHOTOGRAPHY.

PRINTING IN PLATINUM.

W. M'ARTHUR.

It is not an easy matter to convince the beginner in photography that the simplest of all printing processes, and probably the most economical, is the platinotype. There is a strong attraction to P. O. P. for the average worker of little experience in watching the fascinating growth of the image. It appears to be such a simple matter to remove the print when the exposure is complete and to pass it through the various solutions.

All this is perfectly true, and given a fair neg-

ative, paper which has not been imperfectly stored, toning baths which have been properly compounded, and absolute cleanliness in a chemical sense, there is no obvious reason why every print should not be successful. Yet even the most successful workers reckon upon a percentage of failures, and in the case of beginners the percentage is usually a high one.

In the toning and fixing of gelatino chloride prints, the principles involved are complex and have not been thoroughly elucidated even by those who have brought great knowledge and experience to bear upon the subject. There is,

therefore, the less reason for wonder that the photographer working only by empirical rules laid down for his guidance and by the light of nature should make occasional mistakes.

In the case of the platinotype process the problems are simpler, and although the salts with which the paper is coated are easily susceptible to injury and require great skill in their manipulation and preparation, all this does not affect the photographer, who has only to deal with the paper after its manufacture. The paper is coated with a compound of iron and platinum salts, of which the iron alone is sensitive to light, giving an image of a greyish brown tint.

When the exposed print is floated upon or immersed in a solution of potassium oxalate the iron salt is dissolved, and at the same moment the platinum salt, which is in intimate contact with the iron is, in those parts where the light has acted, reduced to the black or metallic stage, and is held permanently in position, being imbedded in the fibre of the paper. The amount of platinum deposited and, in consequence, the degree of blackness in the image, is regulated by the exposure given.

In the high lights, where the paper is protected by the denser parts of the negative, the action upon the iron is very slight, and the amount of platinum deposited is so small as scarcely to tinge the white paper, while in the shadows the amount deposited may be so great as to become solid black. The finely divided metallic platinum being soluble only in *aqua regia* (a mixture of nitric and hydrochloric acid) and not at all affected by climatic influences, the image is absolutely permanent, as it can be destroyed only by means which at the same time cause the destruction of the paper. Properly speaking, no fixing bath is required, development and fixation taking place simultaneously; but a clearing bath of dilute acid is necessary to remove the remains of the iron from the paper, and until this is done the paper must not be placed in plain water.

As the paper is easily damaged by moisture—the touch of a damp finger tip would ruin it—it is desirable that the beginner should purchase it in cut sizes. At the same time he should purchase what is known as a calcium-chloride storage tube. This is a canister having a false bottom of perforated metal, between which and the true bot-

tom a piece of asbestos saturated with calcium chloride solution and dried, is stored. Calcium-chloride greedily absorbs moisture, and in doing so keeps the paper absolutely dry. The joints of the lid and the bottom are damp-proof, either by rings of india-rubber fitted to the joints in some patterns, or applied in the form of rubber bands outside the joints in others. A very efficient storage tube can be had in the “new” pattern for small sizes at a lower price.

On examining the tin in which the paper is sent out it will be seen that the cover is securely sealed by the label. On cutting this and removing the cover the true lid is disclosed underneath and this latter is soldered down, preserving the paper perfectly for a very long time. A cutter will be found inside the cover, and by sliding this as far as it will go, replacing the cover on the tube and turning it round with a little pressure, the true lid is cut out. The ragged edges left after cutting should be smoothed down level with the inside of the tube and the roll of cut sheets enclosed in their wrappers drawn out and transferred to the storage tube—together with a supply of calcium-chloride.

The paper is as sensitive to damp as to light, and if the cover of the tube were not sealed with rubber bands there would be a strong possibility of the paper being spoiled within a very few hours. Properly stored the paper will keep in good condition for many months, but if the tube is repeatedly opened, the calcium-chloride should be occasionally examined, and if it is at all damp it should be removed from the outer wrapper and dried. This may be done by putting it upon a piece of thin iron and placing it on the fire till all moisture has been driven off. Unless the rubber bands fit closely there is always a risk of moisture creeping into the tube.

The preparations for printing are very similar to those adopted in printing upon any other photographic paper, except that additional precautions should be taken against damp. It is well to make a point of drying the printing frames—if they have been used in bad weather—by storing them for some hours in a warm dry room, or, if they are wanted in a hurry, by drying them near the kitchen fire. Care must be taken not to over-heat them or they may warp and so cause the negatives to break. The negatives should be dried

face upwards over the gas flame or in front of a fire till they are warm to the touch and till the moisture which collects on the glass side has been driven off. Sheets of thin india-rubber are sold as excluders of damp from the printing frames and are most useful, but these also should be dried before use. Spoiled celluloid film negatives from the negatives from which the gelatine has been cleaned off serve the same purpose. It is desirable that all negatives used in platinotype printing should be coated with waterproof varnish; not that there is the same risk of them becoming stained as when printing on P. O. P., but because gelatin absorbs moisture, and paper which is printed in contact with damp negatives will have a tendency to give muddy prints.

The hinged back of the printing frame having been removed and the negatives fitted in, film side upwards, the blinds in the room should be drawn, or the operation conducted at some distance from the window, as the paper is distinctly more sensitive to light than is P. O. P. The tube is then opened and one sheet of paper taken out. It will be noticed that the face side is a bright yellow, the back being white. The paper is then laid with the yellow side in contact with the film or face side of the negative and the back of the frame replaced and fastened down. The storage tube should be closed at once and the rubber bands replaced.

Practically the only thing to be learned in platinotype printing is the depth to which the image should be carried, but as the image is fainter in tint than that on a piece of print-out silver paper, and in a color to which the beginner is unaccustomed, a few trials will have to be made before a correct judgment can be formed. To acquire this power of judgment speedily and economically it is a good plan to cut one sheet of paper into four strips and to print these one at a time. While one strip is being printed the others should be kept in the storage tube.

The printing frame should be placed in a good light, though not in direct sunlight, for the more quickly the prints are made the less risk is there of the paper becoming damp. With a negative of good color and reasonable density printing takes place very quickly. In a few minutes the frame should be taken indoors and one-half of the back opened to permit the print to be examined.

The image, as previously stated, is of a grayish brown tint on a yellow ground, and all detail that is to appear in the finished print should be visible, though faintly, after exposure. If the exposure is judged to be sufficient the strip may be cut in half, one part developed and the other kept in the storage tube as a guide when printing the other strips.—*Photography, London.*

CONCLUDED IN SEPTEMBER.

REMOVING FILMS.

A. Sodium fluoride, 6 gr; water, 4 oz. *B.* Sulphuric acid, 6 drops; water, 1 oz. Both solutions can be used until exhausted. Place the negative in *A* for a couple of minutes, then place directly in *B*; after another couple of minutes touch the film with finger from one corner. It will soon leave the glass.

Very good also, in the case of a broken negative, for transferring the film on to another glass. In this case, place—before stripping—in 5 per cent chrome alum solution for half an hour. Wash well and proceed to strip.

FOCUSING CLOTH.

Any one who has wrestled with the orthodox focusing cloth in a high wind, will agree that it cannot be regarded as an ideal method of securing a well illuminated image on the focussing screen. In bright weather, too, when a strong light is reflected from the surface of the ground, and comes streaming in at every aperture left by the cloth, it is equally difficult to determine the value of the lighting of the subject upon the ground glass. To obviate these troubles the writer has had in use for many years a bag arrangement made from a remnant of black velvet. One end has a piece of elastic band sewn in so that it will just slip over the back of the camera and remain taut. The other end is of such dimensions as to allow of its being slipped over the operator's head. By this means all extraneous light is blocked out, and the image appears with unusual brilliance upon the screen, enabling the worker to more accurately gauge the requisite exposure. It also permits of the image being seen distinctly all over the plate when the lens is stopped down, and a better judgment is possible as to the stop suitable in each instance. In interiors, where the light is poor, it is indispensable, and no one who adopts it will ever return to the old methods.—*Photographic News.*

“What is worth doing, is worth doing well.”

AMATEUR WORK

77 WILBY ST., BOSTON

DRAPER PUBLISHING CO., PUBLISHERS.

A Monthly Magazine of the Useful Arts and Sciences. Published on the first of each month for the benefit and instruction of the amateur worker.

Subscription Rates for the United States, Canada and Mexico \$1.00 per year. Single copies of any number in current volume, 10 cents.

TO ADVERTISERS.

New advertisements, or changes, intended for a particular issue, should reach the office on or before the 15th of the previous month.

Entered at the Post-office, Boston, as second-class mail matter Jan. 14, 1902.

AUGUST, 1904.

Model making, as a means of acquiring experience along mechanical and engineering lines, possesses much greater value than those who have not investigated its possibilities are aware. From model steam engines, dynamos and motors much can be learned regarding their operation, which is of direct practical value when applied to the operation of larger machines. Recognizing this great practical value to readers of this magazine, it is our desire to present descriptions of such machines as would be interesting and valuable, and we would, therefore, be pleased to receive descriptions, together with suitable illustrations, showing what our readers are doing in this line.

Do not forget our special book offer announced in the July issue. To any one sending us \$1.25 we will send AMATEUR WORK for one year and a copy of either Norrie's "Induction Coils" or Avery's "A B C of Dynamo Design." The first is a book of value to those interested in coil construction, and the second gives much valuable and useful information for builders of small dynamos or motors.

Attention is called to our new department, "Handy Hints for Amateurs." Contributions to this department are solicited that it may be made of as much practical value as possible.

Those who have recording to do or writing of articles for publication will be interested in the following table of abbreviations, which is sent out by a committee appointed by the American Institute of Engineers:

Name	Abbreviation.
Inches	in.
Yards	yd.
Miles	spell out.
Pounds	lb.
Grains	gr.
Tons	spell out
Gallons	gal.
Metres	m.
Millimetres	mm.
Centimetres	cm.
Kilometres	km.
Kilogrammes	kg.
Grammes	g.
Milligrammes	mg.
Kilogramme-metres	kg-m.
Metre-kilogrammes	m-kg.
Seconds	sec.
Minutes	min.
Hours	hr.
Linear	Lin.
Square	sq.
Cubic	cu.
Per	spell out
Fahrenheit	Fahr. or °F.
Centigrade	cent. or °C.
Percentage	per cent.
Volts	spell out.
Ohms	spell out.
Watts	spell out.
Kilowatts	kw,
Kilowatt-hours	kw-hr.
Amperes	spell out.
Brake horse power	b. h. p.
Electric horse power	e. h. p.
Indicated horse power	i. h. p.
British thermal units	B. t. u.
Gramme-calories	g-cal.
Kilogramme calories	kg-cal.
Magnetomotive force	m.m.f.
Electromotive force	e.m.f.
Revolution per minute	rev. per min.
Circular mils	cir. mils.
Miles per hour per second	miles per hr. per sec.
Candle-power	c. p.
Watts per candle.power	watts per cp.
Mean effective pressure	spell out.
High pressure cylinder	spell out.
Diameter	spell out.

JOINTS IN WOOD-WORKING.

FRANCIS L. BAIN.

II. The Matched Joint.

Having given proper consideration to the extensively used glue or butt joint, we will next give our attention to the splined or keyed joint; also the matched or groove and tongue joint. Of the two named the splined is more desirable, everything considered, particularly because there is no unnecessary waste of material, as with the groove and tongue. For example, suppose it is desired to join several pieces of some valuable wood together with as little waste as possible and it is necessary that each piece (only $3\frac{1}{4}$ in. wide in the rough) shall finish 3 in. wide when glued up. By referring to the illustration it can be seen that *A* (the splined) could easily be made to conform to the specified measurements, while *B* (the groove and tongue) would need so much more extra width from which to form the tongue on one edge, that it would be impossible to joint up the stock properly and tongue it and retain the specified width. Aside from the reason just given, it is a well known fact among cabinet-makers and woodworkers in general, that a tongue or spline formed of a separate piece of wood is much stronger than a tongue formed on the edge of one of the pieces to be joined together.

The relative value of these joints being apparent, we will take up the construction of the splined joint, first calling attention to one rule which always governs the making of a splined mortise and tenon, or groove and tongued joint, namely:—The key, spline, tenon or tongue, as the case may be, should always be just one-third of the thickness of the stock of which it forms a part. Hence, having prepared the various pieces exactly as if making a butt joint, a groove should be made in all joint edges which shall be twice as deep as it is wide, then the outer corners of each groove should be rebated or lightly planed off, as illustrated at *C*, to allow an easier entrance for the spline and to preclude any possibility of an imperfect joint from raised edges. Then the splines should be carefully planed up, preferably

from a harder wood, so they will just fit in the groove snugly, without any looseness or play. When properly fitted apply a thorough coating of



A-Showing 3" exposure after jointing and grooving stock only $3\frac{1}{4}$ " wide in the rough.



B-Showing impossibility of obtaining 3" exposure under same conditions as above.



C-Splined joint rebating at x.



D-Matched joint masking at a.

thin glue to both grooves, also to the joint edges, then fit the spline carefully into one groove, place the piece of stock in a vise, spline uppermost, and

placing the second piece of stock over the spline, groove downward, carefully face the pieces together, applying cabinet-makers' clamps after the united pieces have been properly aligned. When making this, as well as other joints, be careful to avoid the mistake so common to a great many workmen, sandpapering surfaces which are to be glued together, as satisfactory results are never accomplished in this way.

The groove and tongue joint are made similar, in some ways, to the splined joint. A plow plane is used for grooving the board for the latter, while matching planes should be used for the

former. After the matching has been properly done a bead is often moulded on the face side of the stock, just behind the tongue, to mask the joint, as shown at *D*. The glueing process is practically the same as with the splined joint, except that the tongue is fixed instead of moveable.

If very many pieces of stock are to be joined together by either method, it is advisable to cleat across one side or the other in order to prevent buckling of the various pieces, which is sure to occur if they are subject to any weight or pressure, unless they are properly backed up or secured in some other way.

TOOL MAKING FOR AMATEURS.

ROBERT GIBSON GRISWOLD.

I. Kinds of Steel, — Forge for Tool Making, — Set of Useful Punches.

The art of tool making is one most valuable to the amateur worker, and should be practised whenever the opportunity presents. There are many special tools needed by the amateur that cannot be obtained in stores, and to have them made would entail quite an expense. Those that can be obtained are often very expensive and sometimes of inferior grade.

As to the selection of the steel, this is best determined by the use to which the tool is to be put. For instance, it would be a waste to use a high-priced steel such as Musket, Novo or Jessops for tools like centre punches, while for small, delicate tools whose use requires great care and delicacy of touch, the very best grades of tool steel should be used, as they last indefinitely.

Of the many grades of tool steel, the ordinary rolled bar will do for the heavy tools, but for lathe tools the better grades should be used. These are generally of such composition as to require a special treatment other than the simple water hardening process. The treatment of each steel will be taken up as its use is spoken of later on.

The ordinary tool steel, commonly spoken of as a high carbon steel, is best for making special shaped tools, as it submits readily to forging and can be readily worked with a file to shape before hardening and tempering. Under this head would come special forming lathe tools, dies, punches, etc. Whenever it is necessary to work the tool to shape by filing or turning, a steel of this class must be used, as grinding is the only operation that some of the special steels will submit to other than hammering while hot.

In the case of ordinary lathe tools, which are forged to shape and finished on an emery wheel, any of the

special steels may be used, many of them being self-hardening, or air-hardening. These tools must not be hardened in water, as they will not stand it, generally cracking off completely, or else so far that the first touch breaks off the edge.

As a necessary requisite in tool making is a good heating furnace. this will be described first. In it all operations for forging, hardening or tempering may be easily performed. A coal fire is sometimes useful, and perhaps necessary for large pieces, but as the amateur rarely has such large tools to make, the gas forge here illustrated is far more cleanly, convenient and quicker. Its greatest advantage is the control feature. It may be made as hot as necessary, or just a low red heat may be maintained for a long period. It is free from disagreeable odors and noxious fumes, and the work may be seen at all times, which is practically impossible in a coal fire.

The illustration, Fig. 1, shows the furnace complete. The heater is an ordinary gasolene torch, such as is used by electrical repairmen and painters. The entire outfit should stand in a hollow tray of wood lined with asbestos paper $\frac{1}{4}$ in. thick, both on the bottom and sides.

The oven of the forge is made of fire-brick $1\frac{1}{2}$ in. thick. The bottom and top bricks are each $7 \times 12\frac{1}{2} \times 1\frac{1}{2}$ in.; the two sides $3 \times 12 \times 1\frac{1}{2}$ in. and the ends $3 \times 4 \times 1\frac{1}{2}$ in. One of the end bricks is trimmed to fit the end of the furnace oven and act as a door. The four uprights or corner pieces are made of $\frac{3}{4} \times \frac{1}{2}$ in. angle iron, which also serves for legs. One end, lower, of each leg is split and a foot turned over to serve as a lug to screw to the base. The other side of the split end is cut off. Through holes drilled in the angles, $\frac{1}{4}$ in. rods, threaded

at the ends and provided with nuts, pass and support the oven, as well as bind the bricks together. The top brick has a 2 in. hole cut in it near the front for the escape of the gases, while the lower brick has a similar hole at the rear for the entrance of the flame. This hole is covered by a pipe made of fire clay and baked, the section of which is shown at Fig. 1, *d*. A few holes or grooves may be cut in the under side of the brick, which will serve to give a hold for the plastic clay before this pipe is baked on.

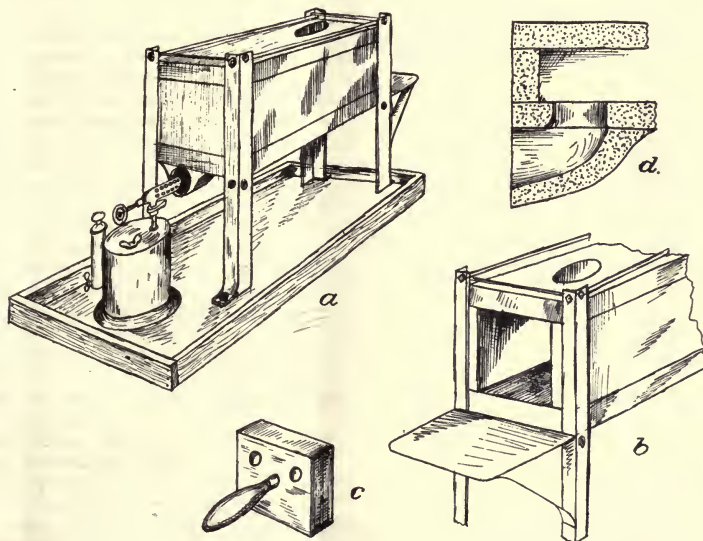

A small sheet iron shelf or hearth is fastened to the front as shown at *b*. The small door brick, *c*, is provided with a loose wooden handle which is inserted in a hole in the brick, an iron pin 2 in. in diameter having been driven into the handle for this purpose. Two peep holes are also bored in this cover through which the progress of heating may be observed. This door should fit loosely so that it will not bind when heated. Fire-brick can be readily cut with an old saw, and holes may be drilled with an old iron file fastened at one end, hardened and ground like a flat drill; this drill can be held in a bit brace.

Some small pieces of fire-brick should now be cut, upon which tools may be rested while heating, say $2\frac{1}{2} \times 1 \times 1$ in., and a few $2\frac{1}{2} \times 1 \times 1\frac{1}{2}$ in. These serve to hold the work off the floor so that it can be heated evenly all around. When a high temperature is required for forging, the piece may be placed over the hole in the rear where the flame will strike it direct.

An anvil should be provided nearby upon which the hammering can be done. While a heavy block of steel, mounted on a post planted in the ground, forms a fair anvil, it is better to make a pattern of wood and

have it cast in iron, if steel cannot be had. The foundry will chill the face if asked. A good hammer and two pairs of tongs will be sufficient at first. A bucket of water should stand beside the furnace, as well as a small bucket of brine (salt water) and a can of fish oil for use in tempering.

Since the ordinary carbon steel presents less difficulty in working than the other varieties, we will consider its use first. In heating any steel, be careful not to over heat it, which is easily done. For forging, only a

bright red heat is necessary for small tools. Too high a temperature burns the steel, and no subsequent treatment will repair the damage.

A good preliminary lot to work on will be a set of centre punches. These punches are almost constantly in use and should be well made. It seems to be a common opinion that almost any piece of round steel ground to a point will do for a centre punch, but with careful workers such is not the case. The set should comprise the following:—A heavy punch for solid, hard pieces, and in starting a large drill; it should be at least $\frac{5}{8}$ in. diameter, with a conical point about $\frac{3}{8}$ in. diameter at the base, as shown in *a*, Fig. 2; punches *b* and *c*, which are used for lighter work, and punch *d*, which is used only in laying off work. Accurate work cannot readily be laid off with a thick punch, owing to its hiding the intersections of the lines.

Many punches are turned from the rod and hardened without any forging, but the more work put into the steel at the working point the better will be its grade. Its grain will be finer and the working edge will stand up in service far better.

After the punch is forged to shape, heat the point to

a dull red and instantly plunge the point *only* into the brine bath, immersing it about $\frac{1}{2}$ in. When cold, or at least black, rub a bright spot thereon with a piece of emery cloth tacked to a flat stick, and then hold in the light until the heat in the stock of the punch begins to color the bright spot a straw yellow. At this point plunge the entire punch into the water and move it about until cool. Should the heat remaining in the punch be insufficient, lay the *body* of the punch over the top hole of the furnace and draw the color to that mentioned above. It must be remembered, however, that all work on each punch, except grinding the point, must be done before hardening, so each should be finished with file and emery cloth before hardening.

or driving pins, bolts, etc.; *g* is a square end punch often found useful in corners and in special work. Punches *j* and *k* are for driving pins through holes where a taper end punch would get stuck; *l* is an off-set punch often used when it is impossible to reach with a straight one, and *m* is very handy in bending the end of a pin so as to make it hold, similar to riveting. Hammers often bruise the work, especially in close quarters. The head should always be kept slightly round, which prevents "brooming" and lessens the liability of an injured hand from a glancing hammer blow.

In hardening and tempering, only the points should be hardened and the temper drawn so as to leave the stock of the punch soft and able to withstand blows without breaking. Always grind the points to shape after hardening and exercise care not to burn the thin edge on an emery wheel. When the edge of a tool blues, it shows that the steel has lost its hardness at that point and should be ground down until hard metal is reached.

Below is given a table of colors and temperatures for tempering, and the tools which are tempered at each particular color. These colors always refer to the color at the working point, and the color must "crawl" from the body toward the working edge. This insures the hardness decreasing in an even gradation.

TABLE OF COLORS AND TEMPERATURES FOR TEMPERING.

Color.	Temp.	Tools.
Very pale yellow.	430° F.	Scrapers for brass, steel-engraving tools, slight turning tools, hammer faces, planer tools for steel and iron, ivory and bone cutting tools, wood engraving tools.
Straw yellow.	460° F.	Milling cutters, wire drawing dies, boring cutters, screw cutting dies, taps, punches and dies, pen knives, reamers, half round bits and chasers.
Brown yellow.	500° F.	Stone cutting tools, gouges, hand-plane irons, twist-drills, flat drills for brass, wood boring cutters, drifts.
Light purple.	530° F.	Edging cutters, augers, dental and surgical instruments, cold chisels for steel.
Dark purple.	550° F.	Axes, gimlets, cold chisels for cast iron, saws for bone and ivory, needles, firmer chisels, cold chisels for wrought iron, hack saws, framing chisels, circular saws for metal, screw-drivers, springs, saws for wood.
Dark blue.	570° F.	
Pale " "	610° F.	
Blue, tinged green.	630° F.	

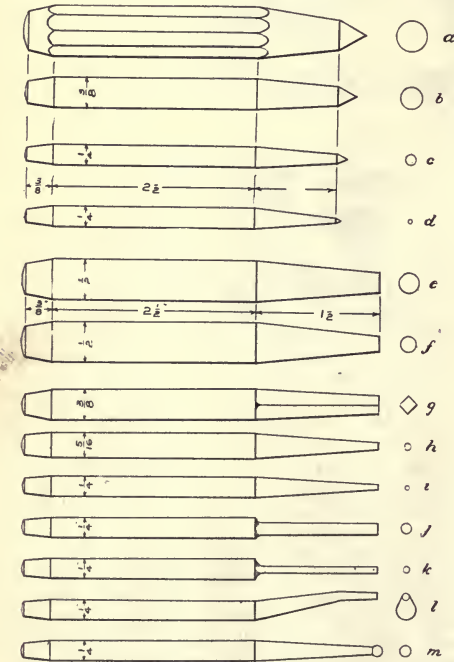

It is upon the property possessed by steel of taking on certain colors at different temperatures that tempering depends. A steel may be made extremely hard in water, but it would be so brittle that the first blow would crack the point off completely. Upon reheating the hardened piece to a definite temperature, indicated by its color, this hardness is reduced and the tool is thus graded in its degree of hardness to suit the work upon which it is to be used. A list is given below showing the various colors and corresponding temperatures that are used in tempering various tools.

In Fig. 2 is also shown a set of punches very useful in general work. Punches *e*, *f*, *n* and *i* are for starting

A few don'ts for forging, hardening and tempering.

- Don't hurry.
- Don't strike too hard.
- Don't overheat the steel.
- Don't heat the steel too quickly. This heats the outside and not the centre.
- Don't hammer hard when the heat falls below dull red. Use light taps then in finishing.
- Don't allow the red hot steel to "soak" in the furnace.

- Don't use two heats where one will do.
- Don't harden the tool where it is not needed.
- Don't have tools too hard. It is easier to resharpen a dull tool than to reforge a broken one.
- Don't hold the tool still in the bath. Move it constantly, except where hardening only the point.
- Don't forge too thin an edge on a tool. Make the cutting edge on a grindstone or emery wheel.
- The following article will treat of lathe tools.

SOLDERING.

H. M. CHADWICK.

II. Using Bunsen Burner and Blow Pipe.

The Bunsen burner and the blow pipe are needed by one who would become proficient in the art of soldering. A cheap and satisfactory Bunsen burner may be constructed as follows:

Make a small box of the size shown in the sketch and fit it with a hard wood cover. This kind of wood is burned much less readily by hot solder than pine or whitewood. Pour a quantity of molten lead into the bottom of the box, being careful that the lead is not heated much above the melting point, as it will burn the wood if too hot. A handful of shot or iron filings may be used in place of the lead, the object being to weight the burner so that it cannot be easily overturned. *A* and *B* are pieces of umbrella tube, *C* is a piece of iron or brass pipe about $\frac{1}{2}$ in. outside diameter, *D* and *E* are pieces of brass or iron, and are drilled to admit tubes *A* and *B*. Brass should be chosen by anyone not having a lathe, as it can be drilled with a twist drill, held in a bitstock. The position of *D*, which enters the pipe, *C*, should be turned or filed to a good fit. The small hole in *D* is about 1-32 in. diameter, and should be central with the pipe, *C*. Drill four 3-16 in. holes in pipe *C*, near the bottom, for the admission of air.

Solder all joints as noted in the sketch. This can be readily done with the soldering iron, carrying out the directions of the first article in AMATEUR WORK for July.

Bore a hole in the side of the box to admit pipe *A*, and also one in the cover to fit closely around *C*. Mix enough plaster of Paris to fill the box, and pack it tightly around the base of the burner. Scrape it off flush on top and nail down the cover. The Bunsen burner is to be connected to an ordinary gas-burner with a piece of rubber hose. The blow-pipe is a necessary tool to be used in connection with the Bunsen burner. It is well to buy this article, as the manufactured ones are lighter and better than any that the amateur can make.

To produce a blast flame, put the large end of the blow-pipe in the mouth and turn it so that the small

orifice points horizontally, quite close to the Bunsen flame and at a point about two-thirds of the distance from the base to the peak. Blow steadily, using the mouth as an air reservoir. After a little practice it

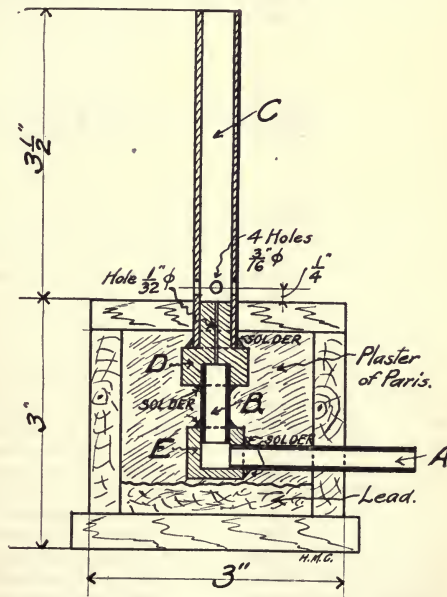

BUNSEN BURNER.
SECTIONAL ELEVATION.

will be found that air can be taken into the mouth with the tongue independently of the act of breathing, and that a steady stream of air can be forced from the blowpipe.

The flame thus produced will be found to consist of two portions, one within the other. The inner is called the

reducing flame. It is the hotter of the two and is the one which should be applied to the article to be heated. The outer is called the oxidizing flame; it will change to an oxide any piece of metal placed in it. The application of the reducing flame to metallic oxides will free the oxygen, leaving the metal with which it has combined.

The flame of the Bunsen burner is of the same nature as the blast flame, but it is not so hot and powerful, since the air mixture is caused by the natural draft through the holes in the base of the burner.

Suppose we wish to solder together two small washers in order to get one of double thickness. In this case the blowpipe will not be needed. Clean each piece carefully and brush on one side with flux. Cut a small piece of solder from the stick, place it on one of the washers and hold this in the Bunsen flame with a pair of pliers. The solder will melt and run all over the washer in a thin film. If too much solder has been used, brush off the surplus before it can harden.

Now hold the two washers with the trimmed sides in contact, in the flame, pressing them together with pliers or hand vise until the solder is thoroughly melted and the surfaces appear to adhere. Remove

them from the burner, keeping up the pressure on the pliers until the solder has set. Clean the bits of solder from the edges with a file or scraper. If the job has been well done only a thin, silver line will mark the joint.

Pieces to be soldered together that cannot be held with pliers or hand vise should, if possible, be wired into position, or, if wiring is impracticable, press them into a mass of adhesive substance made of plaster of Paris and clean sand mixed half and half with water, of course leaving exposed the parts to be soldered. Sometimes putty will answer this purpose. Again, certain articles may be held by nailing them to an asbestos covered wooden block or piece of pumice stone. Whatever method is used, all contact surfaces of any size should be thoroughly tinned before fastening.

It is convenient to have the burner connected to the gas supply by a long hose so that it can be held in the left hand and moved to any convenient angle, while the blowpipe and blast flame are directed with the right. The flux may be removed from soldered articles by boiling them a few minutes in weak sulphuric acid.

To use the blast flame successfully only requires practice as the solder follows a clean joint very readily.

HOW TO MAKE ELECTROTYPES.

S. R. BOTTONE.

The enthusiastic amateur who has succeeded in producing some of the beautifully artistic work of which the lathe is capable, or who has in his possession a coin or medallion from which he requires to take a duplicate, will be pleased, and agreeably surprised, by the charming results that can be obtained by reproducing these in *copper*, by electro deposition. The process is at once simple and inexpensive, and by a little modification can be used to give reproductions either precisely similar to the original ones or ones in which the reliefs and depressions are reversed. As the latter, in ornamental turned work, are very effective, we shall describe the method of obtaining these first.

The operator will provide himself with two or three good "dry cells". A convenient size measures 6x2". He will also require a saturated solution of sulphate of copper (blue vitriol), which he can make up by pouring one quart of boiling water on one pound of copper, stirring frequently with a stick or glass rod until cold. The solution should be made up in a glazed earthen vessel. When quite cold about one and a half fluid ounces of oil of vitriol should be added to the blue fluid, in a fine stream, with constant stirring. The addition of the oil of vitriol will cause the solution to get hot. It must be allowed to cool, when it may be placed in a stoppered bottle ready for use. Several discs of thin sheet copper (about 1-16" thick) of varying diameters, according to the size of the work to be

reproduced, will also be needed, and to the edge of these (which are called "anodes") is to be attached a wire by drilling a hole near the edge of each disc and inserting therein one end of a 10" length of No. 16 copper wire and burring it over the plate by hammering. This makes good contact without soldering, which is to be avoided. The next requisite is a rather deep, flat-bottomed, circular, well-glazed earthenware dish. A soup-plate will answer very well, unless the objects to be copied are very large, in which case one of the square white earthen dishes used by photographers, wherein to wash their prints, may be used. Two or three yards of No. 18 or No. 20 bare copper wire will also be required for the purpose of connecting up the wooden ornamental turned work to the negative pole of the dry cell.

Being provided with the necessaries, the operator selects the turned work which he desires to reproduce in copper, and brushes over the worked surface with a paste made of good fine plumbago (blacklead) and a little water. The brush made use of must not be so hard as to mark or in any wise deface the delicate tracery of the original; but, on the other hand, it must be sufficiently firm to enable the operator to get up a brilliant, metallic-looking surface like that of a well-polished stove. For convenience of future reference we will call this black-leaded surface "the front" of the mould (technically termed the "cathode"). The

purpose of performing this operation is to render the wood, which would not otherwise conduct electricity, conductive on this surface. It must be borne in mind that wherever the blacklead has been applied *there* will the copper be deposited. Hence, to prevent waste of battery power, copper and time, care must be taken not to carry the blackleading too far up the sides of the work. A little way up it must reach, so as to enable a good contact to be made with the wire, which will afterwards serve to connect it to the negative pole of the dry cell. The best way to effect this is to take a strip of paper and roll it tightly round the sides of the work, leaving about $\frac{1}{4}$ " bare all round near the front of the mould. Holding this tightly in the left hand it will be easy to blacklead and polish the edge as well as the front without encroaching too far up the sides.

When this has been satisfactorily effected, the paper strip, which served as a guard, can be removed. Now, taking a piece of the No. 18 or No. 20 bare copper and gripping one end in the vise, he will wind it two or three times round the blackleaded edge of the work, so as to grip it firmly and make good electrical contact with the blacklead under it. The extremities of this wire are brought together and twisted tightly, so that the coils may not loosen. The wire should now be cut off at a distance of about 10" from the work, and bent upwards at right angles to the front of the mould. An anode is now selected, having a diameter as nearly as possible that of the front of the mould. (This wire, so far as it will be immersed in the copper sulphate solution, must be painted over with a little Brunswick black, otherwise it will be eaten through by the solution.) The other end of this wire must then be clamped under the terminal affixed to the carbon (or positive) pole of the dry cell and then bent twice at right angles in such a manner that the anode can lie flat at the bottom of the dish, which must be placed near the dry cell. The dish should now be filled to a height of about 1" to 1 $\frac{1}{2}$ " from the bottom, with the copper sulphate solution prepared as directed. The work to be copied is now attached, by its slinging wire, to the zinc (or negative) pole of the dry cell, and the wire so bent that the front of the mould if immersed in the solution as far as the wire binding extends or, say, for a depth of about $\frac{1}{2}$ ". It should lie perfectly horizontal, facing but *not touching*, the anode, at a distance of about $\frac{1}{4}$ " to 1" from its surface. In immersing the mould, care must be taken to avoid air bubbles, and this can be done by letting down the front of the mould, somewhat tilted, so as to allow any air bubbles to escape; the wire can afterwards be straightened to cause it to lie horizontally. Great care must be taken that *good metallic contact* is made between the two wires and their respective dry cell terminals, and also that no contact occurs, either between these two wires on the one hand or between the mould and the anode on the other. After thus connecting up, the front of the mould should be allowed to remain in the solution for about fifteen minutes. It should then be examined in order to judge of the success of the work.

If the binding wire shows that it has received a rosy-pink deposit, beginning to extend to the edge and creeping round to the front of the mould, all is going well—the current is of the right strength; and if the mould be carefully replaced in the solution, the terminal contact being maintained tight and good, it will be found that after ten or twelve hours' immersion the entire surface of the mould will have received a delicate coating of copper. To get a layer 1-16" thick it may be useful to continue the operation for three or even four days, or even to replace the dry cell by a fresh one, according to the size of the mould. But if on examination, it is found that the surface of the binding wire and of the front of the mould are coated with a ruddy brownish mud, tending to fall to the bottom of the dish, and especially if bubbles of gas

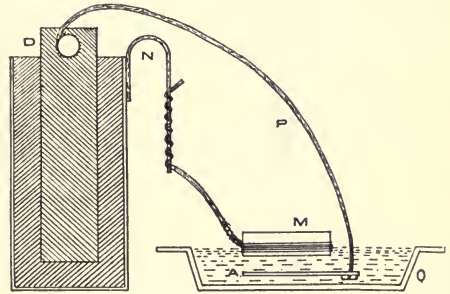

form on and round the mould, it is a sign that the current is *too strong*. In this case it will be necessary to remove the anode further away from the front of the work, or even to insert a "resistance" in the shape of a foot or two of No. 36 iron wire between the anode and the carbon terminal of the dry cell. When it is considered that the copper deposited has attained sufficient thickness, the mould should be removed from the sulphate of copper solution, the wire detached from the dry cell and the mould washed for some time in a stream of running water, after which it should be slung up by its wire to dry thoroughly in a warm place. When the work is quite dry the binding wire is untwisted and the wire carefully unwound from round the edge of the work. If the copper deposit is very thick at these points it will be advisable to file it down cautiously all round, so as to avoid breaking away any of the copper deposited on the front. Having thus filed away any copper that may have extended round the edges of the work, the front of the mould should be held for a few seconds before a clear fire so as to warm the copper coating. This will cause it to expand slightly, after which, by cautiously pushing with the fingers from the back of the mould, the copper coating or "electrotype" can be easily detached. It may then be washed and brushed up with a soft nail brush and soap and water; or it may be "bronzed" with blacklead or lacquered, if it is desired to preserve the beautiful surface it pre-

sents when first detached from the mould. The work or mould, if soiled with blacklead, may be cleaned with a soft tooth brush moistened with benzine. It may be necessary after this to brush up with soap and water, using a fresh, clean brush.

When it is desired to produce a facsimile of the article to be copied a trifling modification must be made in the manipulation. This consists essentially in preparing, first, a wax mould or cast from the original, from which mould the copper electrotype is produced. To this end take a strip of paper long enough to make four or five turns round the sides of the object to be copied. This must be bound round the edge so as to extend up above the face of the work to a height of nearly half an inch, and tied tightly round the sides. The whole should now be laid on a flat table face upwards. Sufficient good beeswax to cover the face of the work to a depth of about $\frac{3}{8}$ " is now melted in a perfectly clean pipkin or ladle. The surface of

the work and the inside of paper binder are now heavily breathed upon so as to prevent the wax adhering, when the melted wax is immediately poured in to a depth, as we have said, of about $\frac{3}{8}$ ". The mould should now be allowed to stand for an hour or two to set and harden thoroughly. The paper binder is then removed, the wax mould pulled off and three or four turns of No. 20 wire bound round the edge, the surface and the edge of the mould carefully blacklead with a very soft camel's-hair brush. It will not be advisable to wet the blacklead, but, using fine powder, breathing on the mould will suffice to render the surface sufficiently adhesive to take a good polish. The blacklead mould is now to be treated precisely as recommended for the reversed facsimile. At Fig. 1 is shown sectionally the proper position and connections of dry cell wire to anode, depositing dish, mould and wire from mould to negative pole of cell.

Engineering World, London.

THE HIGH TENSION ENGINEER.

A paper read by T. M. Lincoln before the 13th. convention of the Canadian Electrical Association.

There are two schools in which the electrical engineer may receive his training, but only one in which he must receive a course before he can be called a high tension engineer. Those things which are learned in the schools equipped with professors and laboratories and mathematical text books must be supplemented by the things which can be learned only in the school of experience. These two schools are quite different in method. The college instructs in theory and in those methods of doing things which have become standard by universal adoption. The college teaches positive knowledge. In the school of experience, on the other hand, one is more apt to learn how not to do it, and by the elimination of the unsuccessful, arrive at the goal of success. The knowledge gained by experience is more often negative.

Put to the fresh college graduate the problem of the amount of distance to be left between the conductors of a high tension transmission line. His answer will involve, most likely, the jumping distance of the voltage to be used, the length of span, the sag, and perhaps a liberal factor of safety. It is experience only that will show that his premises are wrong and that the equation to determine spacing of high tension wires depends very little on the voltages to be carried and almost entirely on such little things as the average length and ohmic resistance of cats, the spread of wing of owls and cranes and eagles, and the average length of scrap baling wire, together with the strength of the average small boy's throwing arm.

The college graduate enters practical work invariably feeling that the great danger of his work lies in his liability of receiving a shock from the high tension

conductors. Not until he has had experience with accidents of an electrical nature does he learn that it is the danger of being burned he has to fear more than the danger of shock. My own experience, and I think it will be checked by the large majority of those in a position to know, has been that the number of electrical accidents in which the victim has been injured by burning is incomparably greater than the number from shock.

The graduate has learned how to make accurate measurements of power. He finds after he has "been up against it" that it is easier to measure power accurately than it is to persuade the customer that his power is being accurately measured.

The man fresh from the college laboratory enters his practical duties with the idea that rubber is one of the best insulators that exists. It is not until he has seen rubber insulation break down in the most unaccountable manner that he finds that rubber as a high tension insulator is extremely treacherous. The deterioration of rubber insulation is probably due to chemical reactions on the rubber induced by the brush discharges, which are in turn caused by the high voltage of the conductor.

The newly made graduate usually has a high opinion of efficiency and can calculate the economy of a transmission to an excessively small fraction. When he becomes responsible for the operation of a transmission line, however, it does not take him long to find out that efficiency is a vanishing quantity when compared to continuity of operation, and that economy is not to be considered as being in the same class as good service.

The technical graduate, in short, may have knowledge in plenty, but his wisdom is to come.

It is furthest from my thoughts to cast any slur upon the technical graduate. I look back upon my own course in electrical engineering and feel that it is the most valuable asset I ever possessed. The technical course is the best of foundations, but it is only a foundation. The end of the college course is rightly called "Commencement." The great advantage of the technical education is that it gives the man proper equipment for overcoming the difficulties with which his experience is bound to bring him into contact. It gives him, as nothing else will, the power of initiative—that most valuable quality that a high tension engineer can possess. There is nothing like the college education to equip a man for making every accident a lesson in "how not to do it," and every failure a stepping stone to success.

Take, for instance, the recent accident to the Niagara plant, in which a fire destroyed the cables on the bridge connecting the power house with the transformer house. The lesson to be drawn from this accident—so plain that he who runs may read—is that where many cables are run together, extreme precaution should be taken to protect against danger of fire. Before the occurrence of this fire there was little sus-

picion that the insulation of cables when lead covered or protected by fire proof braid—as was the case at Niagara—is sufficient to maintain so fierce a blaze without the aid of some other combustible besides the insulation. One accident of this kind should suffice, not only for the Niagara Falls people, but also for any others who have occasion to run many cables together.

The art of long distance transmission as it exists today is the result of the accumulated experience of all those who had to do with transmission work. And the process of accumulation is still going on. Those men who today are designing and operating transmission plants are the moulders of the art. Their expedients for improving service or reliability or for cheapening cost are noted, and when successful have their influence on future installations.

The high tension engineer, no less than the man in any other department of human endeavor, may find in failure the way to better things. It was Roosevelt, the strenuous, who gave utterance to the sentiment that absence of failure accompanied only lack of effort. "The uses of adversity are sweet," and the engineer may well heed the words that Shakespeare puts into the mouth of the Duke, who, exiled to the forest of Arden, finds "tongues in trees, books in running brooks, sermons in stones, and good in everything."

A SENSITIVE GALVANOMETER.

A sensitive and well-made galvanometer may be used for a variety of purposes. Not only may it be used for the testing of resistances, both high and low, but by the use of a proper shunt may be used to measure strong currents, and by the use of a high series resistance may be used to measure the voltage of an electric circuit. An old telephone generator furnishes ex-

amples that may vary somewhat from the one used in the following paper, but the reader can easily modify his instrument to suit his needs.

A bottomless box with a glass top will be required, mounted upon a base board, the whole being suited to be screwed to the wall as shown in Fig. 2. This box is 7 in. by 13 in. outside measurement, and 4½ in. deep.

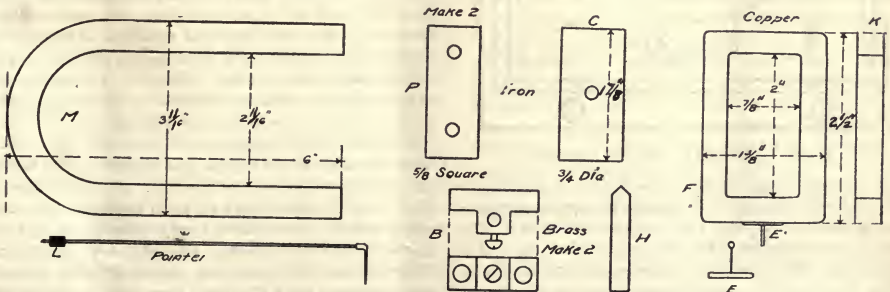

FIG. 1. DETAILS OF GALVANOMETER. (Not to scale.)

cellent magnets for the construction of such a galvanometer. A magnet which the writer secured from such a source measures 6 ins. in length and is made of steel, which is ½ in. by ½ in. The more powerful the magnet the better will be the results. Its dimensions

The base board should be 15½ in. by 8½ ins. The box is secured to the base board by two hasps, one on each side, two or three dowel pins helping to hold the box from slipping. This method of securing the box is adopted so that the case may be easily removed, giving

access to the working parts of the instruments inside.

The magnet used being $\frac{3}{8}$ in. wide, two pieces of iron, shown at *P*, are made for pole pieces. These are $\frac{3}{8}$ in. square and $1\frac{1}{2}$ in. long, and have bored in them two holes $\frac{1}{4}$ in. in diameter, through which are to pass screws to secure them in place. Secure the magnet firmly to the base board, its poles being $9\frac{1}{2}$ in. from the

In the exact centre of this space is to be secured an iron cylinder, shown in Fig. 2, and also at *C* in Fig. 1. This is $1\frac{1}{8}$ in. long and $\frac{3}{8}$ in. in diameter. It is to be fastened to the base board by a screw passing completely through it. This should leave a clear space of $1\text{-}32$ in. on each side of the cylinder. It is well at this point to take a very small, sharp chisel and cut two grooves in the base board, these grooves being extensions backward of the spaces between the poles and the cylinder on each side. These grooves are necessary in order to allow the coil shown in Fig. 2 to swing freely in either direction without striking the back board.

Take next a piece of the thinnest copper procurable. It should be very thin in order to be light and to take up as little space as possible. From the sheet copper make a frame such as is shown at *F* (Fig. 1). It is rectangular in shape and measures 2 in. by $\frac{3}{8}$ in. inside, and $2\frac{1}{2}$ in. by $1\frac{1}{8}$ in. outside. Its width is $\frac{1}{2}$ in. As shown in the side view at *K*, it is a frame with the edges bent up so as to form a deep groove running around the face of the frame for holding a coil of fine wire. Where a frame overlaps it must be neatly soldered. At the corners the turned up edges will be cut away, but this will do no harm. Line the slot in this frame with a layer of thin but tough paper, fastened in place by shellac. This serves to insulate the frame, Then wind the slot full of No. 36 single silk-covered magnet wire.

The ends of this coil are left projecting, one at each end. Shellac the outer surface of the coil and set it aside to dry. Now make two little pieces shown at *E* (Fig. 1). They are made by taking a piece of thin copper, $\frac{1}{4}$ in. by $\frac{3}{8}$ in., and soldering to the centre a projecting wire of stiff brass $\frac{1}{4}$ in. long. Flatten the outer end of the brass wire and drill a small hole through the flattened part. These little pieces are then bound on to the ends of the coil by a silk thread, so that the projecting wires form a spindle about which the coil may rotate. For this reason they may be so adjusted as to project from the exact centre of each end. Also care must be taken in bending them on to insulate them from the coils by slipping a piece of thin paper under them. Then the projecting ends of the coil are soldered to these little strips, one at each end, and the superfluous wire cut off.

Two pieces of brass should be made like those shown at *B* and also at *H* (Fig. 1). As shown in Fig. 2, these are to support the coil in position. The hole through *B*, therefore, should be $\frac{3}{8}$ in. from the back side of the piece, and *H* should slide freely through *B*, but may be secured by a set screw. One of the pieces shown at *H* should be threaded and provided with a thumb nut as shown at *T* (Fig. 2). One end of *H* should be flattened and drilled, as were the ends of the projecting wires on the coil. Now procure some fine silk fibres, preferably of raw silk, and pass one end of the fibre through the hole in the upper wire spindle of the coil, securing it firmly by a drop of sealing wax. In a like manner secure a fibre to the lower spindle. Then,

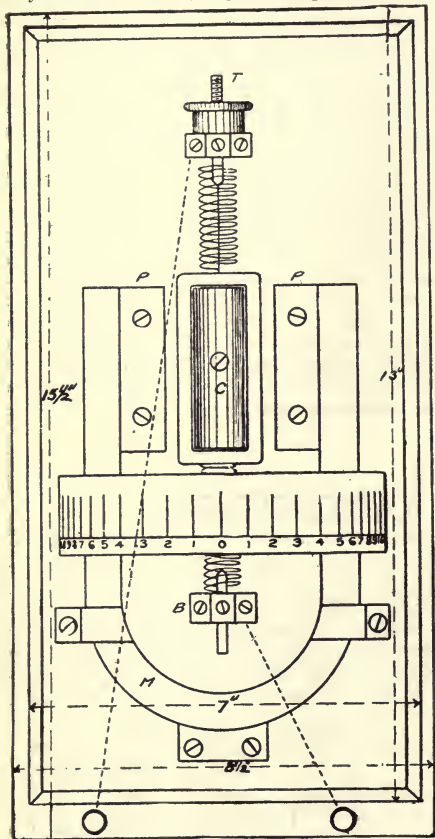

FIG. 2. GENERAL ARRANGEMENT.

bottom and at equal distances each side of the centre line. A block of wood at each side of the magnet, another at the bottom, and two clamps—one at each side—ought to secure the magnet firmly in place so that it cannot slip. Then screw the pole pieces into place, taking care that they rest firmly against the inner poles of the magnet. This will leave 17-16 in. of clear space between the poles, if the dimensions given have been followed. If the magnet used has dimensions differing from those given at *M* (Fig. 1), allowance will have to be made in the pole pieces so as to leave the proper space between them.

with a *T* in place (Fig. 2) pass the fibre through the hole in *T*, pull it up until it is of the right length, and fasten with sealing wax. Do the same at the bottom and the coil will be suspended so as to swing freely in the space between the cylinder and the poles.

Current is led into and out of the coil by two very small, slender springs shown at the top and bottom. They are made from No. 36 (no finer) German silver wire, coiled around a small pencil so as to make a very weak spring. By carefully removing *T* and leaving the fibre slack, the ends of this coil may be soldered to *T* and to the pivots of the coil. This process should be repeated at the bottom. A circular scale, made of a piece of white Bristol board, projects forward from the instrument and is bent so as to have the axis of the coil for a centre. The radius of the arc of this circle is $2\frac{1}{2}$ in. A pointer (shown in Fig. 1) is glued to the bottom of the coil, and its front end moves over the card-

board scale. This pointer is made by taking a strand from a broom and fitting a thin piece of copper at its outer end to serve as an indicator. The back end of the pointer projects beyond the coil and is counter-weighted with a small piece of lead, as shown at *L*.

Thus the silk fibres serve to suspend the coil in place so that it may swing freely, while the coiled springs encircling the fibre carry the current into and out of the coil, and also serve to bring the needle to zero after being deflected. Binding posts at the bottom are connected to the upper and lower suspensions as shown.

If the amateur is skilful he can improve the instrument by using two very fine hair springs in place of the coiled German silver springs. These may be secured at a watchmaker's, and besides being more reliable, are not so stiff as the German silver springs, and therefore render the instrument more sensitive.—*The American Telephone Journal*.

JUNIOR DEPARTMENT

For the Instruction and Information of Younger Readers.

ELEMENTARY MECHANICS.

J. A. COOLIDGE.

VII. Fluids.

All substances that flow are called fluids, whether they be liquids that are heavy like water, and that exert a noticeable pressure because of their weight, or gases like air, whose weight is not so apparent, and yet flow more readily than liquids and exert pressure everywhere.

The fact that the air that escapes so easily from the tires of our bicycles does not fly off into space but remains near the earth's surface, shows that it has weight just as all other matter, and consequently exerts a downward force.

We must start with this law:—That fluids exert a pressure in all directions, and that at any given depth in a fluid the pressure is equal in all directions. This may be seen by a simple experiment. Take a common vegetable can and punch small holes, one in the bottom and one or two more at different depths in the side; then thrust it quickly, with the open end up, into a pail of water and it will be seen that the water spurts in through all the holes, but with greatest force through the one in the bottom. The water presses in all directions and has greater pressure the deeper we go.

For our apparatus we need a long necked bottle about 4 in. long and 2 in. diameter, a cork stopple,

about 3 in. of rubber tubing $\frac{1}{4}$ in. diameter inside, 3 in. glass tubing of same diameter, and a file. We must now cut off the bottom of the bottle. This is not an easy task, but with care it can be done successfully.

With the file mark a deep scratch mark (see *ab*, Fig. 20). Heat one end of a poker red hot in the stove, touch first point *a* then point *b*, causing a fine crack to run from *a* to *b*. Draw the red hot poker slowly around the bottle from *b*, and this crack will follow the poker until *a* is reached. The bottom will now come off the bottle, leaving a fairly smooth edge. This can be improved by grinding a little on a whet or grindstone.

From some dentist a piece of thin sheet rubber 3 in. square should be got and tied with a thread over the bottom of the bottle, as in Fig. 21. A small funnel, *F*, should be inserted in one end of the tube, and the glass tube in the other end and then through the cork of the bottle. A hole in the cork for the glass tube may be made with a round file. The whole apparatus will look like Fig. 20 when the bottle is inserted, or like Fig. 21 when the bottle is erect.

EXPERIMENT XV.

Fill bottle, tube and funnel full of water and hold as in Fig. 21. Hold *F* on a level with the top of the bottle and slowly raise it; as it rises the rubber sheet bulges out, showing a constant increase in the pressure upon it. Keep *F* one foot above *B* and notice the curve of the rubber; turn the bottle on its side and observe again. Turn the bottle as in Fig. 20 and keep *F* one foot from *B*. In all these we shall find the

pressure the same and that the law of "pressure being equal in all directions" is true.

EXPERIMENT XVI.

Take the funnel out, hold the apparatus as in Fig. 20 and pinch the rubber between thumb and finger at *F*. Holding this in one hand, raise the bottle about two feet above *F*, and then let a little water escape at *F*. We then have an illustration of a water system. *B* is one reservoir; *F* the end of a pipe which, after pass-

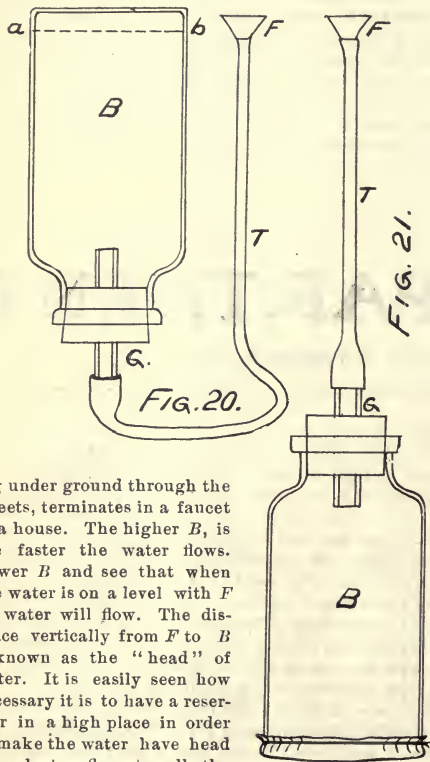

ing under ground through the streets, terminates in a faucet in a house. The higher *B*, is the faster the water flows. Lower *B* and see that when the water is on a level with *F* no water will flow. The distance vertically from *F* to *B* is known as the "head" of water. It is easily seen how necessary it is to have a reservoir in a high place in order to make the water have head enough to flow to all the houses. In some cities water has to be carried many miles in order to find enough difference in level to give sufficient pressure. Ask any plumber to explain to you the pressure gauge with which he tests the water faucets.

About 1648 Pascal learned that if a certain pressure were exerted on a part of the liquid in the interior of a vessel filled with a liquid, every other equal part received the same pressure. He took a strong cask, fitted a tall tube into its head, and then filled the cask and tube with water. Where the tube entered the head of the cask there was a pressure of the weight of the water in the tube. If the tube had an area (or cross section) of .5 sq. in., every other equal portion of

the inside of his barrel had an equal pressure. He found the large area inside his barrel suffered so much pressure that his cask burst.

EXPERIMENT XVII.

Set a box *X* with a ruler *R* tied to one side as in Fig. 22. Cut a thin disc of wood, *D*, glue a cork, *L*, to this piece of wood and a long bristle or broom straw, *P*, to the cork. Cut a piece 4x4 in. from a 2 in. plank, and with an extension bit bore a hole, *O*, large enough to hold the neck of our bottle and $\frac{1}{4}$ in. deep. With bit $\frac{1}{2}$ in. diameter, continue this hole, *S*, nearly to the bottom and bore a hole, *V*, in the side to meet *S*. With tube and bottle filled with water remove funnel, slip the block, *K*, over the tube and neck of bottle and insert in position as seen in Fig. 22. Replace the funnel, *F*, and place disc, *D*, and pointer, *P*, on top of the rubber sheet, *B*. Place the box with ruler, *R*, about $\frac{1}{4}$ in. from *P*, so that any rise or fall in *B* can be

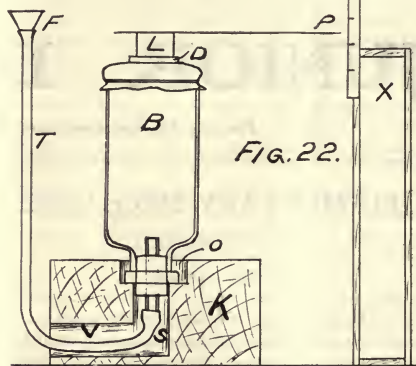

measured. The rise in *P* will give us the means of measuring any increase in pressure on *B*.

Start with *F* and *B* on the same level and note the position of *P*. Raise *F* three inches. Does *P* rise? Raise *B* three inches more and record any change in *P*. Continue taking as many readings as possible. Do not be disappointed if the increase in each new trial is not exactly uniform. The sheet of rubber prevents perfect results. Enough if we find an increase of pressure at *B* for a rise at *F*. What causes this pressure? Can it be the trifling amount of water in the tube *F*?

EXPERIMENT XVIII.

Arrange the apparatus as before, only put a 4 oz. weight on *D*. Note the position of the pointer when *F* is three inches above *B*. Place an 8 oz. weight instead of the 4 oz. weight on *D* and raise *F* until *P* stands where it did before. Try a pound weight on *D* and raise *F* until *P* is in the same place. Manifestly it is not the extra weight of water in *F*, for that amounts to only a small fraction of an ounce for a rise in *F* of three inches. Recall Pascal's barrel and you have the

explanation. If the tube is $\frac{1}{4}$ in. diameter and F is raised four inches, the increase in pressure down the tube and upon the opening into the bottle at T is only about .1 oz. But this pressure is on an area of only about .05 sq. in., and this is transmitted to every equal area of B . If, instead of a rubber tube, we had one of metal entering a metal cylinder instead of a bottle; and if, instead of pouring water into a funnel, a piston were forced down F , the water would be forced into the larger cylinder. Now replace B with a large piston and we have the essential parts of a hydraulic press. A frame work above B must hold the substance to be compressed, and the piston at F must be fitted with a lever or pump handle. With such a press a tremendous power is gained, a force of 20 or 30 pounds often producing a pressure of 8 or 10 tons.

CORRESPONDENCE.

OUR readers are invited to contribute to this department, but no responsibility is assumed for the opinions expressed in these communications.

Letters for this department should be addressed to editor of AMATEUR WORK, 77 Kilby Street, Boston.

They should be plainly written on only one side of the paper, with a top margin of one inch and side margins of one-half inch.

The name and address of the writer must be given, but will not be used, if so requested.

Enclose stamps, if direct answer is desired.

In referring to other letters, give the number of the letter referred to, and the date published.

Illustrate the subject when possible by a drawing or photograph with dimensions.

Readers who desire to purchase articles not advertised in our columns will be furnished the addresses of dealers or manufacturers, if stamp is enclosed with request.

No. 78. MELROSE HIGHLANDS, MASS., June 28, '04.

How much wire is needed for the "Sensitive Relay" described on page 131 of the April, 1904, AMATEUR WORK?
C. W. W.

About one pound of No. 36 cotton covered magnet wire is required for the "Sensitive Relay".

No. 79. MONTREAL, QUE., June 19, '04.

Can I put a $1\frac{1}{2}$ h. p. engine on an ordinary bicycle, and would it be safe?
P. H. R.

Bicycles, as they are now built, are not strong enough to sustain the engine and other equipments. To have a safe motor bicycle it would be desirable to build a complete one with heavy tubing and other parts to match.

No. 80. FRANKLIN, N. H., June 6, '04.

I have made a chloride of silver battery as described in Vol. I., No. 12, but fail to get any current. I used chloride of silver that I purchased at a drug store and sterling silver wire. Can you tell me where the fault lies?
J. L. J.

The information you send is not very definite. It is possible that the chloride of silver purchased is not a good solution, but rather more probable that in making your cell you have a short circuit; that is, the negative and positive elements are in contact at some point. Would suggest that you look into the latter and see if the trouble does not lie there.

No. 81. ROCKFORD, ILL., July 1, '04.

I take advantage of your "Correspondence" to ask a few questions which are bothering me. I think most of your electrically inclined readers will welcome more articles on the subject of wireless telegraphy, especially on its operation.

1. (a). What capacity condenser does a one-inch coil require? (b). A two-inch coil? (c). A three-inch coil?

2. A two-inch spark coil requires twice the amount of secondary wire as does a one-inch coil; a three-inch coil three times as much as the one-inch coil. Does the same follow in the case of condensers?

3. If I have two 2-microfarad condensers and connect them in multiple, so to speak, is the resulting capacity four microfarads?

4. Is a water or gas pipe a good ground for wireless telegraph work?

5. Of what material and shape should the air conductor of wireless telegraph apparatus be?

6. Some time since an article appeared in your paper on the construction of a mercury interrupter. Since the primary coil current passed through a spring of fine copper wire, this interrupter would be useless on a coil of any size. How could it be made to interrupt a coil of twenty or thirty amperes?

7. On what size of spark coil do you consider that a mechanical interrupter is more practical than a common vibrating interrupter?

8. Does a mercury or mechanical interrupter require a condenser?
R. N. M.

1. (a), (b), (c). The capacity of the condenser to be placed across the contacts of a vibrating interrupter is figured according to the amount of primary battery and speed of make and break. One must put the right capacity of condenser across the primary circuit to reduce sparking contact to a minimum and to give the best output in the secondary. The peculiarities of construction of any one cell preclude giving off hand the absolute condenser capacity necessary. Best results are obtained by experiment in the vicinity of 1 to 2 microfarad for 20 volts primary battery, for any length of secondary spark.

2. The amount of wire used in a secondary does not give spark length. It is how it is wound on in turns and layers. One cannot measure wire length in a coil giving a certain spark, and estimate that twice as much will give twice as great a spark.

3. Two 2-M. F. condensers in multiple give 1 M. F. capacity.

4. Water and gas pipes should not be used for a ground. The best ground is one buried specially for the purpose.

5. See August AMATEUR WORK.

6. The mercury interrupter you mention was for small coils. To handle 20 amperes requires different apparatus. An article covering high current interrupter will appear shortly.

7. Vibrating interrupters, if well made, will work all right on any size coil where highest frequency is of no account. Mercury and mechanical interrupters are high speed.

8. Mercury and mechanical interrupters are improved by a condenser across the make and break points. The capacity of such a condenser is a matter of experiment and calculation, based on construction data of the coil and primary battery to be used.

No. 82, MALDEN, MASS., June 1, '04.

Will you please inform me how to make the composition used in the hectograph. I know that gelatine is used, but do not know the proportions. E. P.

The composition is made from the best gelatine and glycerine. One ounce by weight of gelatine is soaked over night in cold water, and in the morning the water is poured off, leaving the swelled gelatine. Six and one-half fluid ounces of glycerine are now heated to about 200° F. (93 C.) on a water bath preferably, and the gelatine is added thereto. The heating is continued for several hours. This operates to expel the water and to give a clear glycerine solution of gelatine.

The composition is then poured into the tray, which must be perfectly level in order to obtain a surface nearly even with the edge. It is then covered so as to keep off the dust. The cover, of course, must not come in contact with the smooth surface. In six hours it will be ready for use.

No. 83. BOSTON MASS., June 14, 1904.

I am making the wireless telegraph apparatus which was described in the June and July, 1902, numbers. Will you kindly answer the following question: When using the apparatus in an exhibition hall can the ground wire be in a box of damp earth instead of the ground? I have been very successful so far in the making. N. A. T., Jr.

The ground wire must have a complete circuit to moist earth, this meaning actual ground contact. If a metal drain pipe from the eaves of the building can be reached from a window, and such drain pipe reaches down into the earth two or three feet in making connection with a sewer, you could temporarily connect your ground wire to the same, making the connection with several turns in connection with the bare metal. A painted pipe would give poor connection. Do not connect with interior pipes, like gas and water pipes, as the voltage is high and might also interfere with telephone and other low tension connections, which are frequently made to interior piping. If this is not possible, it will be advisable to have ground wire put out the nearest window, the earth end having a piece of copper plate about a foot square embedded in moist earth, the connection with the wire and copper plate being soldered.

TRADE NOTES.

Amateur photographers should inquire of dealers for the Franklin developing clips. By means of these clips plates can be handled throughout development without having the hands come in contact with the solutions used, thereby preventing stains and other objectionable features. They are manufactured by Parsell & Weed, 131 West 31st Street, New York City. who also make the Franklin lantern slide vise for holding lantern plates when binding. It is much the best thing obtainable for that purpose. Circulars will be mailed upon request.

The attention of those interested in the equipment of manual training schools is called to the wide range of machines manufactured by the American Wood Working Machinery Company of New York City. An examination of their catalogue shows that this company can fill orders for about every kind of machine needed in woodworking. Scroll, band and circular saws, turning lathes, planers, mortisers in various styles and many sizes. The catalogue of this company will be mailed upon request to those interested in this class of machines. The salesrooms in New York, Chicago, New Orleans and Boston are very convenient to many buyers making it possible for them to have personal inspection of the machines they propose buying.

The large demand for "Oil Stones, How to select and use them." published by the Pike Mfg. Co., Pike, N. H. has required a new edition. This interesting booklet contains much of value to every mechanic. It is mailed upon request, and all readers are recommended to send for it. A new catalogue has also just been issued by this company showing their full line of sharpening stones.

A new catalogue of the Ohio Electric Works, Cleveland, Ohio, shows that this enterprising firm is keeping right up to date in the variety of electrical devices they offer. Send for this catalogue if interested in electrical experimental work.

Drinking water from the barrel cactus is used by the Indians of the desert. The barrel cactus grows among the desert hills west of Torres, Mexico, and the Indians cut the top from a plant about 5 feet high, and with a blunt stake of palo verde, they pound to a pulp the upper six or eight inches of white flesh in the standing trunk. From this, handful by handful, they squeeze the water into the bowl they have made in the top of the trunk, throwing the discarded pulp on the ground. By this process they secure two or three quarts of clear water, slightly salty and slightly bitter to the taste, but of far better quality than some of the water a desert traveler is occasionally compelled to use. The Indians, dipping this water up with their hands drink it with evident pleasure. In times of extreme drought the Indians use this water to mix their meal preparatory to baking it into bread.

AMATEUR WORK

A MONTHLY MAGAZINE OF THE USEFUL ARTS AND SCIENCES

Vol. III. No. 11.

BOSTON, SEPTEMBER, 1904.

One Dollar a Year.

A TELEGRAPH RECORDER.

FREDERICK A. DRAPER.

Until one has acquired the ability to read telegraphic sounds by ear, some form of recording instrument is necessary to enable messages to be received. The apparatus here described is easily made at small expense, and with it the messages are legibly printed upon the moving tape and can, therefore, be read as soon as the operator has memorized the various characters.

suitable baseboard, the size being determined by that of the parts used for making the receiver.

The works of the clock can frequently be had for the asking at a jewelry store. The requirements are: a strong spring in good working order, and the train of the four gears, that on the spring shaft being the first. The escapement and alarm part are removed. The hour hand shaft

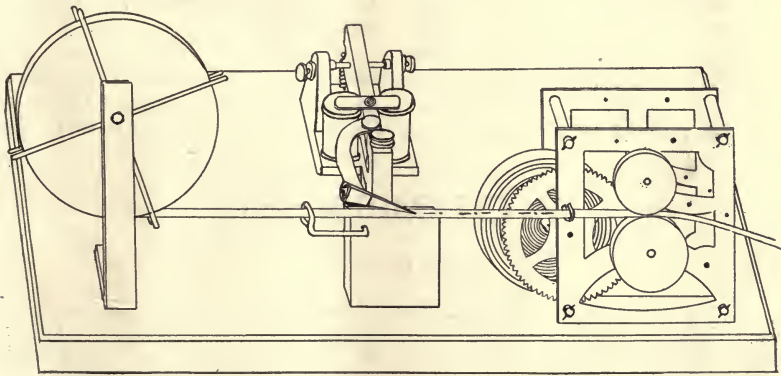

The illustration shows the general arrangement; the works from an old clock provide the mechanism for moving the tape, a common sounder is fitted with a small pen of the kind used for paper ruling machines, the point of which rests on the tape and marks it, the tape being supported under the pen by a small, smooth block of wood. The tape, the kind used in "ticker" machines to be found in stock brokers' offices, is supported by a frame and should unroll with but little friction. These parts are all arranged on a

will be found to project from about the centre, and about 1 in. above will be found the shaft for the trip of the alarm. The latter is removed and a shaft projecting about 1 in. is fitted in its place. To the hour-hand shaft and the shaft just mentioned are fitted two wooden pulleys or cylinders, that on the hour-hand shaft being the larger, and covered with a wide rubber band. The upper pulley is of a size to fit firmly against the rubber covering on the lower one, so that the tape, which passes between them, will have a firm and

even tension. A wire is bent to form a guide for the tape, and fitted to the clock frame.

For attaching the pen to the sounder, a support is made of thin, strip brass, which may be cut from the clock case, the inner end being curved to come under the check nut on the adjusting screw of the armature lever. The outer end is curved to a V shape and at an angle, so that it will hold the ruling pen firmly and at an angle sufficient to cause the ink to flow readily. A block of wood is glued to the base board under the point of the pen, to support the tape, the size being determined after the pen is in position. A wire guide for the tape is also fitted to this block, as shown in the illustration.

The bracket for the tape holder can be made by mortising the end of a piece of wood in the base board, or a 6 in. angle iron may be used, a part of one end being cut off. The tape mentioned comes in rolls 5 in. diameter, with a wooden block in the centre $1\frac{1}{8}$ in. diameter, the tape being $\frac{1}{2}$ in. wide. Other sizes are sold by wholesale paper houses, and the parts should be made for the size of rolls most easily obtained.

To the top of the bracket fit a $\frac{1}{2}$ in. machine screw long enough to project and allow two nuts to go on the outer end after the roll holder is in place.

The roll holder is made from an ordinary spool,

the flanges being cut off and the length being $\frac{1}{2}$ in. greater than the width of the tape. On one end drill four holes to receive wires about $2\frac{1}{2}$ in. long; the holes should be a driving fit for the wires. Then cut a disc the same diameter as the spool, from a piece of $\frac{1}{4}$ in. wood, first boring a hole in the centre slightly larger than the machine screw bearing. Fit four wires to this disc, the same as with the spool. The roll of tape being placed on the holder, the disc is placed outside, and after putting it on the shaft the nuts are put on, the outer one acting as the check nut to prevent the inner one from binding on the disc and spool, and so holding them in place and yet allowing them to turn freely.

When all is completed the tape is carried from the holder under the pen and between the two pulleys of the clock works, the latter wound up and, when desired, allowed to pull the tape under the pen. The illustration does not show all the gears. The fourth one projects at the side so that a trip can be fitted to it, which can be moved by an electric magnet in series with the sounder. In this way the spring can be kept constantly wound up, and the tape started by the first signal received, thus allowing a message to be recorded even if no one is present. The spring of an ordinary alarm clock will operate long enough, without rewinding, to receive quite a long message.

A CHAMBER SET.

JOHN F. ADAMS.

III. Chiffonier for Men.

A chiffonier, designed especially for gentlemen's use, is at present a novelty in the furniture line, but is rapidly becoming very popular, as it allows the wardrobe to be much more conveniently stored than can be done in a bureau or or chiffonier of the usual style. The one here described can easily be made by any one familiar with the use of wood working tools.

The four corner posts are $1\frac{1}{2}$ in. square and 47 in. long. Rabbets $\frac{1}{2}$ in. deep are cut for the end pieces, which are $41\frac{1}{2}$ in. long, 21 in. wide and $\frac{3}{4}$ in. thick. Because of the width the end pieces as well as the top will have to be glued up, care be-

ing used to get a good match with the grain along the joint. The top is 40 in. long, 24 in. wide and $\frac{3}{4}$ in. thick. A frame is also made of strips of birch 3 in. wide, which will measure outside, 37 in. long and $22\frac{3}{4}$ in. wide. The corners are cut out to fit around the posts; this frame fitting under the top and serving to give stiffness to the frame. The back edge is set in $\frac{1}{2}$ in. from the back of the top, the sheathing of the back being nailed thereto. A similar frame is made and put in under the two drawers at the top, and a piece of board $\frac{3}{4}$ in. thick placed between the two frames, dividing the drawers. A similar frame is

also made to go under the lower drawers.

Two narrow cross pieces go across the front, that under the top being $1\frac{1}{2}$ in. wide and that at the bottom 2 in. wide; both are 28 in. long, thus giving 1 in. on each end for tenons to fit mortises cut in the posts. The frames, top ends and cross pieces being cut out and fitted, they are assembled and fastened firmly with glue and screws; the back is then sheathed with $\frac{1}{2}$ in. matched sheathing.

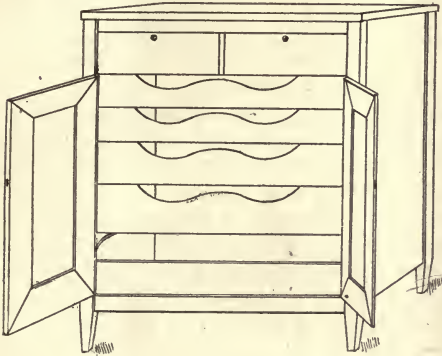

The two top drawers are $17\frac{1}{2}$ in. wide, $22\frac{1}{4}$ in. long, and $5\frac{1}{4}$ in. deep; the fronts are 6 in. deep, projecting $\frac{3}{4}$ in. below the bottom of the drawers, thus concealing the frame upon which they rest. The inner edge of this lower part is also cut away for about 4 in. in the centre to make a place for the fingers, with which to pull them open. The

fronts are flush with the cross piece above.

Two panel doors are then made to fit in the front, which are $31\frac{1}{2}$ in. high and 18 in. wide. The frames are made of $\frac{1}{4}$ in. stock 3 in. wide, the mortises for the corner joints being mitred. Rabbits $\frac{3}{8}$ in. wide and deep are cut on the inner edges for the panels, which are $26\frac{1}{4}$ in. long and $12\frac{3}{4}$ in. wide. All joints should be strongly glued and set up with clamps while drying.

The remaining drawers are all 36 in. long and 22 in. wide, other dimensions being: the two top ones 5 in. deep; the next 6 in. deep, the next 7 in. deep, and the bottom one 9 in. deep, the front board of the latter being only 5 in. wide. The runs for these drawers are made from strips $\frac{1}{2}$ in. square, which are attached to either solid boards or frames placed on the insides between the posts and flat against the inside of the ends. To allow room for the runs, the sides and back of all the drawers except the top are $\frac{5}{8}$ in. less in depth than are the front pieces. The front pieces are cut out to the curves shown, so that the contents of each drawer can be seen. The edges of these curved parts are rounded and carefully sandpapered.

The doors are hung with three brass hinges on each, a bolt fastening is put on the bottom of the left one and a lock on the right one. Locks are also put on the two upper drawers. Nothing has been said about the kind of wood used, this being left to the choice of the maker as well as the finish. In mahogany it makes a fine looking piece of furniture, this being the wood used for making the one from which this description is taken.

PATTERN MAKING FOR AMATEURS.

F. W. PUTNAM.

VII. Methods for Making Split Patterns, — Fillets.

A great portion of cast iron and brass work is so designed as to require the patterns to be "split". That is, made up in two pieces. In a jointed pattern the moulding is greatly facilitated by making the pattern in halves.

A casting for a recessed cylinder is given in Fig. 38, the split pattern being shown in Fig. 39. Fig. 40 shows the pattern in position in the mold, the joint between the two halves of the pattern com-

ing at the parting line between the cope and nowell.

Two pieces of clear dry pine will be required for the pattern, each being large enough to finish 6 in. long, 2 in. in width and 1 in. in thickness. The blocks are left $1\frac{1}{4}$ in. longer than the finished pattern in order that the marks made by the head and tail centres may be removed, and also that enough surface may be left for glue, which is often

used in the ends of the blocks for holding the presses tightly together without its penetrating or reaching the surface of the pattern itself. These two pieces are to be carefully planed on the face and joint sides and should be of the same thickness. The face sides of the two blocks are the surface which form the joint and are shown in Fig. 41, where the two halves are placed face

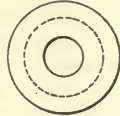
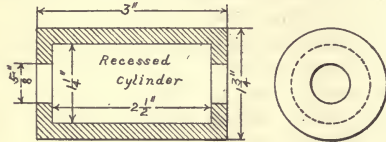

pieces are cut purposely $\frac{1}{8}$ in. less in length than the depth of the dowel hole, and are to be tapered so as to enter and leave the hole easily.

These projecting pins should be carefully tapered or they will cause the molder a great deal of annoyance, and the resulting castings may be

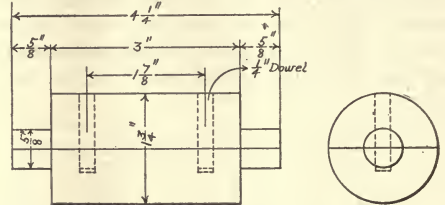

FIGS. 38 AND 39. CASTING AND SPLIT PATTERN FOR RECESSED CYLINDER.

to face with the dowel pins (in this case, concealed dowels are shown) in place. Fig. 42 shows the blocks brought together with the outline of the required pattern drawn upon them, thus illustrating the allowances that are usually made for finishing the pattern.

The pieces should next be dowelled together, either of two general methods being used. The first method is as follows: Clamp the two pieces

imperfect. Many workmen make the pins project a distance considerably larger than its diameter. A short pin, however, governs the position just as well as a long one and is also less liable to stick in the loose half of the pattern, so that for small or medium size patterns it will be found advisable to let the projecting ends stand out from $\frac{1}{8}$ to $\frac{3}{8}$ in. of the large part of the hole, the remainder being tapered off so as to make sure the

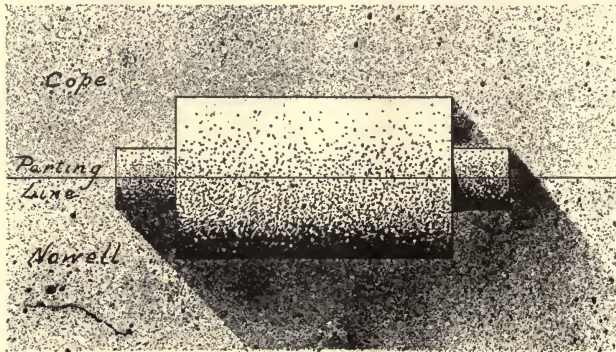

FIG. 40. SPLIT PATTERN IN MOLD.

together with the face sides together, and from the joint side gauge a central line along the outside surface of one of the blocks, marking on this centre line the two points for the centre of the dowel holes. Fig. 39 shows these centres to be $1\frac{1}{8}$ in. apart. Bore holes with a $\frac{1}{4}$ in. auger bit through the top piece and $\frac{3}{8}$ in. into the bottom piece. Cut two dowel pieces long enough to extend $\frac{5}{8}$ in. into the bottom pieces, and glue these dowels into the top pieces. The projecting

pin can be freed easily. The dowel pin should be fairly large in diameter, for the larger the pin the longer it will remain free from warping. It is especially necessary that the dowel pin be absolutely round at the part that fits the hole.

If these precautions are neglected castings will probably result in which the halves will not match. The pins should not fit tight in the loose half of the pattern, as then the halves will not separate when molded.

It frequently happens that it is necessary to keep the outside surface of the pattern unbroken, and also there are many cases in large work where the holes would require boring so deep and the pins made so long that the second method is made use of as shown in Fig. 43 and Fig. 41. In such cases the centres of the holes must be very carefully located and are usually laid out in one of the following ways:

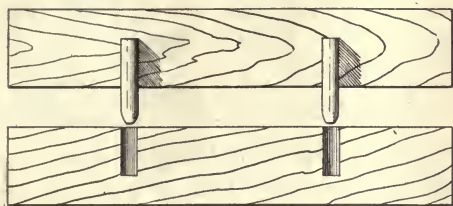

FIG. 41. JOINT FOR SPLIT PATTERN.

Place the pieces side by side with the joint sides touching and the ends even. Make two notches at the joint the required distance apart and, after separating the pieces, square very fine lines with a knife across the face sides of the two blocks. Next set a gauge at half the width of the pieces and mark the intersecting lines, thus giving the required centres.



FIG. 42. MARKING OUT SPLIT PATTERN.

A second method is to locate the holes by laying two small wire nails between the pieces and then tapping the other piece with a hammer or mallet. The heads of the nails will make impressions in each piece, which will indicate the centre of the holes to be bored.

A third method is to provide some ordinary lead shot and make the shallow holes with a bradawl slightly less in diameter than the shot. When pins are to be inserted, place the shot in the hole so that they project beyond the surface, and then proceed to apply a little pressure to the two locks.

It is often found necessary to place the dowel pins at uneven distances from the ends of the pattern, one being nearer the centre than the other, so that the molder can instantly put the two parts of the pattern together without having to turn them half round the opposite way.

After gluing and inserting the pins the two halves of the pattern must be firmly fastened together in such a manner that they can be turned as one piece. There are four ways of doing this and a brief description of each follows:

1st method. The end surfaces for a breadth of $\frac{3}{8}$ in. to $\frac{1}{2}$ in. are brushed with hot glue, after which

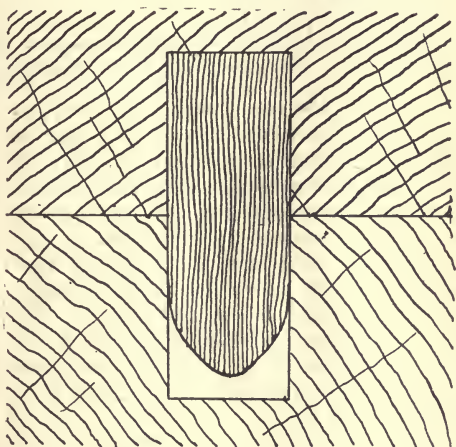

FIG. 43. JOINT FOR SPLIT PATTERN.

the pieces are firmly clamped together until the glue is thoroughly hard. Frequently a piece of newspaper is glued to each piece and glue placed between the two pieces at the ends only. It is not necessary that the newspapers cover the entire surface of the pattern, strips being glued simply between the ends. If this method has been followed the pattern, after being finished, may be separated by inserting a knife blade or chisel between them, leaving a strip of paper on each half. When patterns are secured by glue and paper, care must be taken in turning to avoid catching tools, because of the natural tendency of glued pieces to fly apart owing to the great speed at which they revolve in the lathe. The ends should be turned down to about $\frac{3}{8}$ in. diameter and then

sawed off and finished with a knife, chisel or file. 2nd method. It frequently happens that the pattern maker cannot wait for the glue to harden and set, or it may be, if the pattern is a large one, that it would be unsafe to trust entirely to glue, in which case wood screws are often used at the ends, as shown in Fig. 44.

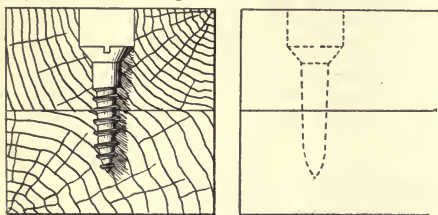

FIG. 44. USE OF SCREWS IN SPLIT PATTERN

3d method. For small and medium sized patterns corrugated steel fasteners are often used for fastening two blocks of wood together. They are made of the best cast steel and are so simple, effective and easily applied as to be very serviceable for a great variety of pattern work.

4th method. Dogs are also frequently used for this work. They are a kind of square staple made of steel, sharp pointed, two of them being driven in each end. While they are very handy both on large and small work, they are rather clumsy, and the use of screws or fasteners is preferable.

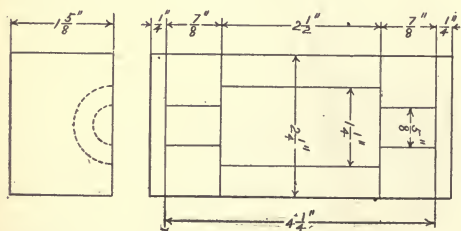
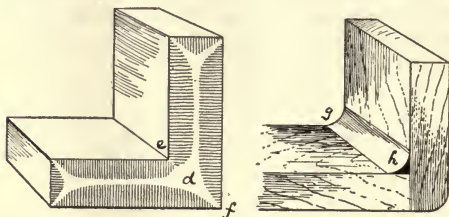

FIG. 45. CORE BOX FOR RECESSED CYLINDER.

Having fastened our pieces together by one of the above methods, the block is next placed in the lathe and turned as though it were solid. Great care should be taken to have the centre spurs exactly in the joint; if any error is not corrected one half of the finished pattern will be larger than the other. To remedy any error, tap the pattern lightly with a hammer in the required direction, immediately screwing up the tail centre

a trifle tighter so as to hold the pattern in the new position. An error can be detected provided the blocks were made the same thickness, by taking a light gauge cut across the block and then carefully comparing the width of the flat surface left on each half.



FIGS. 46A AND B. USE OF FILLETS.

Do not forget the necessary allowances for draft, shrinkage and finish. The draft in the core print ends, *A*, Fig. 39, is finished with a file and sandpaper after the extra stock on the ends has been cut off.

The half core box for this pattern is shown in Fig. 43. The two parts, *B*, are of the same size and should be cut from a single block of wood long enough to allow for finishing to the required length of each piece after the half hollow has been cut out. It will be noticed that the end walls as well as the shell of the casting, Fig. 38, are only

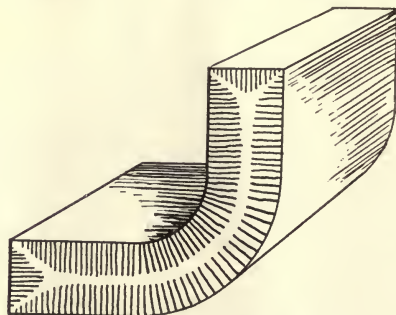

FIG. 46C. ROUNDED CORNER.

$\frac{1}{4}$ in. thick, so that the centre block of the core box, Fig. 45, must be made very carefully to the size required. No further directions should be necessary for making the core box, as the work is done exactly in the same way as explained in previous exercises.

In a previous chapter I took up very briefly the

necessity for fillets. Sharp corners on the inside of a pattern form sharp corners of round when molding and thus give the molder a vast amount of trouble. Sharp corners not only detract from the appearance of the casting, but also weaken the casting, as clearly shown at Fig. 46. At *A* is shown a casting with a sharp corner. As iron hardens crystals seem to form in such a way that their lines of strength, as they are called, are perpendicular to the surfaces, as shown by the lines in this figure. This leaves, of course, an open

space or, rather, a space of irregular crystallization at *d*, and so the casting is liable to break along the line. For overcoming this difficulty a *fillet* is generally placed on the inside corner, as shown at *B*, Fig. 46, *h* being the fillet. It will be noticed that the outside corner of the pattern is also somewhat rounded.

At *c*, Fig. 46, is shown a casting for a pattern having a carefully rounded corner, there being now no space of irregular crystallization, as occurred at *d* in Fig. 46, *A*.

PHOTOGRAPHY.

PRINTING IN PLATINUM.

W. M'ARTHUR.

II. Developing the Print.

The developer may well be made up in bulk, as it keeps well. A special developer known as D salts is sold by the Platinotype Company, and gives admirable results, but neutral potassium oxalate works equally well, giving a good rich black which is preferred by many workers to the bluish black given by the D salts. As full particulars for use are issued with each packet of the D salts, it is unnecessary to detail them here.

In making up the potassium oxalate developer four ounces of the crystals are dissolved in forty ounces of water. A convenient way of making the solution is to tie the crystals in a piece of muslin and to suspend the bag so formed just below the surface of the water in a jug. Solution then takes place quickly, as the heavy liquid sinks to the bottom. If tap water is used the lime salts present in it will react with the oxalate and cause the solution to be opalescent. Except that it is more convenient to work with a clear solution this milkiness does no harm, but by allowing the solution to stand for a few hours the precipitate will settle and the clear liquid may be decanted into a suitable bottle or jar. From this stock solution sufficient for use may be taken and kept in a smaller bottle and used until it becomes loaded

with iron salts from the paper, when it should be discarded. This is a better plan than to return the used solution to the stock bottle. If the potassium oxalate is bought from a reputable dealer it will be in a suitable condition for use, but if strongly alkaline it must be neutralized by the addition of a little of a saturated solution of oxalic acid. Slight acidity in the bath does not impair its action but tends to give cold black. Very slight alkalinity, which may be secured if wanted by the addition of potassium carbonate, gives brownish blacks. The developer is best used at a temperature of from 60 to 65 deg. Fahr. The clearing bath is made by adding one part of good hydrochloric acid to sixty parts of water. The very common variety known as spirits of salts should not be employed. If many prints are to be developed a large jugful of the clearing bath should be made up, as it must not be used sparingly or the iron will be left in the paper and become yellow in time.

A dish a size or two larger than the prints to be developed should have the developer poured into it to the depth of half an inch or more, and the same with the clearing bath.

The usual instructions are to float the paper face downwards on the developer, but in unaccustomed hands there is a tendency for air bells to form in this method of working. A simpler plan, and one to which there is no objection, is to hold the paper by one end face upwards and to

slide it under the solution. If air bells form they are at once seen, and may be broken by shaking the dish. The moment the developer touches the paper development begins and is concluded in a very few minutes. It is desirable to expose the paper so that it may be left in the developer till the action is complete, though slightly over-exposed prints may be saved by removing them from the developer at an early stage.

After the print has been some thirty seconds in the developer, it will be seen that no further action takes place. It should then be removed to the clearing bath in which the yellow coloration is removed. At least three such baths should be used, and the prints should remain in each for five minutes, care being taken to prevent them from sticking together. If any trace of yellow color is seen in the last clearing bath, as may be the case if a number of prints are manipulated at one time, a fourth and even a fifth bath must be given. After clearing, the prints must be transferred to cold water and washed for twenty minutes, when they may be dried by laying them face downward on blotting paper or a clean towel.

To return to the trial strip, if the image has been printed to the correct depth, the remaining strips may be printed upon by way of practice, either from the same or other negatives, using the undeveloped piece that was cut off as a guide. It is, however, hardly likely that the first trial will be exactly right, or, if it is, that the success can be repeated with certainty until a little experience has been gained. It is well to select some point of detail in the lighter half-tone and to watch for the appearance of it when printing. The eye will soon become accustomed to the appearance of correctly exposed prints, and when that point is reached there is absolutely nothing more to learn.

I have said that prints that have been slightly over-exposed may be saved by removing them from the developer before the action is quite complete, when they should at once be placed in the clearing bath. I mention this, not to encourage carelessness in exposing, but simply because the power of correcting faulty exposure is frequently referred to, and the instructions might appear incomplete without it. When it is found that the exposure has been carried too far in a batch of prints and the first has been over-devel-

oped, the next should be slid under the developer and withdrawn as soon as it is completely wetted. The print should be held in the hand or laid on a sheet of glass until all the detail in the high lights that is required appears, and then placed in the clearing bath. Prints treated in this manner are seldom so bright as when correctly exposed and developed, and are frequently mealy in appearance.

It is very frequently stated that under-exposed prints may be saved by warming the developer, and it is so to a certain, though very limited, extent. The aim of the printer should be to expose the prints to the correct stage, when development becomes automatic. When a number of prints have been developed the developer becomes loaded with iron salts and in time will give faulty prints. Should the slightest falling off in quality be noted the bath should be discarded and a fresh portion taken into use. A bath that is too weak will cause platinum to float off the surface of the paper, and if anything of the sort is noticed the bath should be strengthened. After the developer has been used it is better stored in the dark.

Printing in damp weather, or any cause that leads to the paper becoming moist will, in the early stages, tend to muddy looking prints, and prolonged printing in dull rainy weather will lead to the image developing out in an imperfect manner during printing. Usually only the shadows blacken while printing in such cases; the half-tones will develop out when the print is placed in the developer, but the image will be unsatisfactory. Prints from dense negatives should never be attempted on dull damp days, nor begun so late in the afternoon that the exposure must be carried over to the next morning.

When a number of prints are to be made from one negative, it will be found convenient to develop each print as it is made, but when a number of negatives are being printed from, there may be no time for development till the whole batch is completed. In such a case, each print as it is removed from the printing frame should be placed in the storage tube, where it is safe from moisture and may afterwards be developed at any convenient time. On no account should the prints be placed in a drawer or between the pages of a book, as is commonly

and harmlessly done with prints on silver paper. If a piece of paper is too large for a print it should not be torn across, but cut away with a pair of scissors. In tearing it there is always a possibility of particles of the platinum being thrown from the torn part on to the surface of the paper and causing black spots if they remain *in situ*, or white spots should they be brushed off after printing. The plainotype paper recently brought out by the Kodak Company is free from this defect.

A method of local development with glycerine which gives admirable results in the hands of a worker accustomed to use the brush has been much practised of late years. The iron and platinum salts are not soluble in glycerine, which may be brushed over the surface of the print without injury to it. On the application of the developer, also without a brush, it is to a certain extent diluted with the glycerine in the paper, and development takes place less rapidly than in the ordinary manner, thus giving time for the photographer to watch the growth of the image. Development may be still further delayed by adding a proportion of glycerine to the developer.

The print is exposed in the ordinary way, and having been laid on a sheet of glass, the glycerine is brushed well into the paper. It is well to have a finished print side by side with it for reference. Two or three cups containing ordinary developer, developer diluted with glycerine, and plain glycerine are required, together with a supply of camel-hair or sable brushes in various sizes. A brush charged with neat developer is applied to the parts which are to be brought out in full strength and while they are growing in vigor the dilute developer is applied to the surrounding detail which is only required to appear in a light sketchy manner. The edges may be softened or vignettted off by the use of a brush dipped in glycerine. As soon as the desired effect is obtained, the print is immersed in the clearing bath in which the undeveloped parts of the image disappear. The method is one which can only be successfully worked by a person who knows exactly what he wants and who has some training in the use of a brush.

I have said that while the D salts give a bluish black image, that obtained with potassium oxalate tends to give brownish blacks, as does warm-

ing the developer in the case of slightly underexposed prints. The addition of a small quantity of a saturated solution of mercuric chloride to the developer gives tones ranging from a brownish black to a yellowish amber tint. The exact proportion of mercuric chloride to be employed to give certain tints is best found by experiment, the larger the proportions of the mercuric salt the warmer the tone.

When warm tones are required it is, however, more satisfactory to employ the sepia paper. The developer is compounded by adding to each ounce of a solution made by dissolving six ounces of potassium oxalic acid in fifty-four ounces of water, one or two drams of a special solution supplied by the company for the purpose. An alternate developer is made by taking ten parts of the potassium oxalate solution just mentioned and adding one part of a saturated solution of oxalic acid. The developer is to be used at a temperature of 150 or 160 deg. Fahr. An enamelled iron dish is commonly recommended, as it may be placed over a gas ring without fear of breaking. As, however, the enamel quickly cracks, exposing the iron and ruining the developer and prints, it is better to use a granite dish and to keep it and the solution up to the proper temperature in a water bath or on a sand bath. The manipulation and clearing of the prints are precisely the same as with black paper, but greater care must be taken to preserve the paper from the action of light, and in a general way the process lacks the sweet simplicity of the black paper.

The black paper is sold in three grades; AA, a paper of medium thickness and with a smooth surface; BB, a smooth, thick paper; and CC, a rough surface, thick paper suitable for large work. It is also supplied in grades known as A, B, and C. These are for the hot bath process, an older type with which we are not at present concerned, and S signifies the sepia paper.

Prints are mounted in exactly the same way as a photograph on other printing papers. Starch paste is best for the purpose, and a gelatine mountant should not be used except with the thick paper. As the paper does not curl up in the same manner as gelatino-chloride and collo-dio-chloride papers, there is no necessity to mount them at all except when they are to be

framed. A margin which serves the purpose of the mount in isolating the image from its surroundings is obtained by covering the negative with a mask cut to show just as much of the image as is wanted, and then printing on a sheet of paper just large enough to allow sufficient white round the image. Prints on thick paper, either with rough or smooth surface, so treated are in the best condition for storage in a portfolio, and are more pleasant to handle than when pasted on

a heavy mount.

The instructions I have given in detail necessarily occupy a considerable amount of space, but the manipulations are actually most simple. Once the worker has learned to judge when the image is correctly exposed, it is almost impossible for him to go wrong. After a few attempts he will endorse the statement I have made, that the process is at once the simplest and the most economical of all.—*Photography*.

TELEPHONE CIRCUITS AND WIRING.

ARTHUR H. BELL.

IV. Putting up the Line.

In the previous chapters a description of apparatus suitable for operation over a considerable distance. The next matter of interest is the construction of a pole line to carry the two conduc-

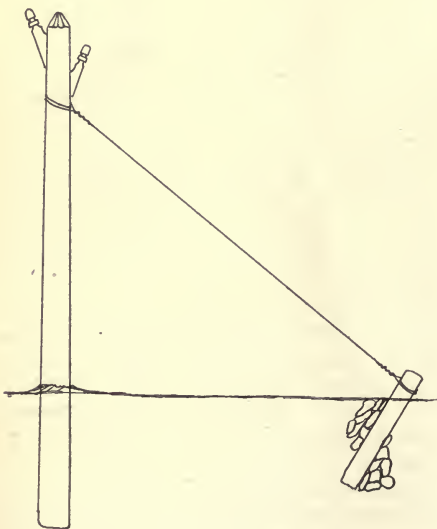

tors from station to station. It is difficult to give specific instructions for such work because of the different conditions to be met with in various sections of the country, especially as regards soil and climate. But a practical understanding may be

obtained from a description of the methods usually followed.

Permanent right of way must be secured in writing from town and citizens for every pole and for the wires and attachments placed thereon, and for the privilege of placing wires and fixtures upon the roofs of disinterested parties. The line should be surveyed as straight as possible, avoiding lengthy curves and wooded sections. One hundred and fifty feet between poles is a fair distance, providing the poles are of a length of twenty to twenty-five feet and set at least about five feet in the ground. On a two wire pole there is no need of cross arms, as insulators may be fastened to the poles, as shown in Fig. 9. On highways, where the wires are to cross from one side to the other, the crossing should be made at an angle of forty-five degrees, and poles should be all of twenty feet above ground, and the sag of the wire should be over eighteen feet from the ground. It may be well to ascertain from town authorities just what rules obtain in the construction of overhead wires. The stoutest poles should be reserved for corners and bends in the road. The top of each pole should be pointed (roofed) and painted. Poles do not require to be set so deep in rocky soil as in mellow earth, in fact, a pole of twenty-five feet length may be firmly set in three feet of rock formation.

In digging post holes it is advisable to dig them large enough to permit the poles to enter readily and to permit tamping. After the pole is in po-

sition the earth should be returned a little at a time and tamped firmly on all sides with a log or heavy device designed for the purpose, and the gravel remaining after filling should be evenly banked about the pole. At all corners and curves special attention must be devoted to anchor guys arranged to support the pole in time of storm. Often times the guy wire may be conveniently fastened to a nearby tree trunk or to a stout, low branch, if the tree is of considerable size. But the most complete way is the burying of a large log or other anchoring surface to which may be attached a heavy guy wire. Permission should be secured for the trimming of tree branches likely to strike against the wires, due calculation being made for the "drop" of wet foliage and snow laden branches.

The line wires may be No. 14 copper for very short lines and No. 12 for longer lines. Galvanized iron wire is often used and will answer very well for private line work. Particular attention must be paid by the amateur lineman to foreign wires along the path of his line. The services of experienced linemen will be required where electric light and power wires are to be passed, and under no circumstances should the inexperienced reader attempt to cross such wires alone and unaided by experienced help. Wires from pole to pole should not be stretched taut, but should be permitted to sag several inches.

In tying line wires to insulators the line wire should never be wound round the insulator but fitted into the channel provided in the knob and secured in place by a piece of strong annealed iron tie wire, one end of which passes over the line wire and is twisted in five or six turns, and the other end passing under the line and likewise turned. This makes a secure hold. A great deal of information that cannot be gleaned from publications will be noted should the amateur arrange to meet a construction gang during its new construction work along the road. Neatness in all things is a foremost requisite, and the amateur should arrange his poles perfectly as regards alignment and sag of line, so that his work will in no way become an eyesore in a community.

A considerable profit on capital invested could be made by two or more enterprising amateurs in the operation of a private line between a village

centre and the railway station, as in many places the railway borders the outskirts of the settlement, and ten cents is but a small consideration for sending a message of twenty-five words or so instead of a half-hour's drive in all kinds of weather to the freight depot, county store or post-office. If properly constructed such a line need never be out of repair during its first year of existence, and the annual expense of maintenance will be principally in station batteries and possibly a receiver cord or two.

This is a matter that should appeal to scores of readers whose home environments will permit a successful carrying out of such a scheme, and numerous opportunities for such lines are to be found in all sections of this country.

An electro-mechanical governor for steam-electric plants invented by M. Routin of Lyons, consists of a solenoid, magnetized by a few series turns, and a coil which is in shunt with the generator. The magneto-motive forces of the two windings are opposed, that of the shunt coil, however, predominating in normal conditions. The field switch, the valve mechanism, and a rheostat in series with the shunt coil of the solenoid, are mechanically connected to the armature of the solenoid. The last named switch performs the function of securing the predominance of the shunt-coil of the solenoid for any position of the latter's armature. Assuming additional load to be put on the generator, the armature of the solenoid will drop a certain distance, because the increased magneto-motive force of the series winding of the solenoid will, by more nearly balancing that of the shunt coil, diminish the strength of the electro-magnet. In falling, the armature will have acted upon the valve gear, at the same time cutting out resistance from the field circuit of the generator as well as from the circuit of the shunt coil of the solenoid. If the load is taken off, the action is reversed and the armature is drawn higher up into the solenoid, and if a short circuit takes place the series coil largely predominates, the armature is drawn right up and the steam is shut off. If the fuse blows into the generator circuit, the same thing occurs, the shunt coil now being responsible for this.

The Japanese explosive, Shimose, has been said to be more powerful than either dynamite or guncotton, Shimose does not explode on percussion, or by fire, and is not injured by wetting. When it is exploded, by a charge of fulminate, it tears a hole greater than would result from the use of a similar quantity of dynamite, and, unlike that substance, its force is equally exerted in all directions.

HANDY HINTS FOR AMATEURS.

Contributions are solicited for this department, and for each accepted article the sender will be given the choice of any one-subscription premium from our premium offers.

BENCH TRIMMER AND SAW BLOCK.

R. G. GRISWOLD.

One of the handiest devices for use in the amateur's shop is a small bench trimmer, such as is shown in Fig. 1. It will repay one a hundred times the time taken to make it well. The sliding knife is simply a small block plane, working on its side.

The base, *a*, should be made of apple or maple, well dried or seasoned and dressed perfectly flat. The edge, *e*, is planed and perfectly straight. A

ions are scratched in the base, *a*, indicating angles of 90°, 60°, 45°, and 30°, or any other intermediate angles desired. These scratches are then filled with a black wax or other pigment and these settings are afterwards quickly made.

The pivoted end of *b* should just touch the bit as it passes, and this will give a support to the wood so that the bit will not break it. The piece is held against *b* with the thumb of the left hand while the plane is moved to and fro with the right. Exceedingly good work may be done with this trimmer and the joints made by it will fit

Fig 1.

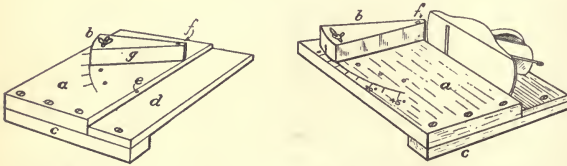

piece, *d*, is then glued to it so that an edge or shoulder is left at *e* just the thickness of the side of the plane. The blade will then cut to the bottom of the piece. The surface of *a* and *d* must be truly parallel. They are glued as a whole to the bottom of *e* and four screws are put in to prevent the thrust of the plane knocking it off. This bottom also acts as a stop against the edge of the bench.

The block, *b*, is also made of maple or apple, is pivoted on a $\frac{3}{8}$ in. pin at *f*, which passes through a snug hole in *a* and is riveted to a $\frac{1}{2}$ in. plate underneath, the latter being securely fastened to *a* with four screws. The hole in *b* must also fit this pin very snugly. At the other end a circular slot encompasses a thumb screw which engages with holes in *a* so that *b* can be clamped in any position desired. The face, *g*, must stand at a true right angle with surface, *a*.

A vertical line is then scratched with a fine point on the end of *b* and by the aid of a protractor placed against the face of the plane when the latter is square against the edge, *e*, several divis-

nically providing the device has been well made.

In Fig. 2 is shown a saw block which may set on the end of the bench. It is very handy when small blocks or strips are to be cut off at either 90° or 45°. The strip, *a*, which is made of maple, is glued to the base. Then a $\frac{1}{8}$ in. brass strip two inches wide is cut into pieces, as shown, so that the angles are exactly 90° and 45° with the facing edge. These are then screwed down with flat head screws and form guides for the thin back saw, whose thickness determines the width of the slots. These brass plates form guides that do not readily wear out, and the device really forms a fair mitre box but is quicker and less in the road. The block, *a*, may be made any height, but $1\frac{1}{2}$ in. has been found to be a very convenient height, as pieces any thicker than 1 in. had best be cut in a mitre box.

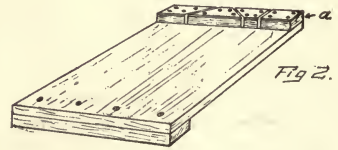

The man who does only what he gets paid for, gets paid for only what he does.

SAILING RULES FOR YACHTS.

CARL H. CLARK.

Before stating the rules certain definitions of the terms used are necessary. A boat is on the *starboard tack* when she has the wind on the starboard (right) side, and is on the *port tack* when she has the wind on the port (left) side.

A boat is *close hauled* when she has her sails trimmed in closely, and is sailing as closely as possible to the direction from which the wind is blowing. A boat is *running free* when she has the wind nearly aft, and is sailing with the wind, and in nearly the same direction, with the main boom at about a right angle with the hull. A boat is *reaching* when she has the wind about abeam, and the boom at an angle of about 45° with the hull.

The rules for avoiding collision between sailing yachts are as follows:—

A yacht which is close hauled on either the port or starboard tack has the right of way over one which is running free. A yacht which is sailing before the wind can easily change her course in any direction, while one which is close hauled cannot alter her course without loss to herself. A boat which is running free must keep clear of every other boat.

A boat which is close hauled on the starboard tack has the right of way over a boat close hauled on the port tack, and also over a boat which is running free. When two boats are running free or "reaching" on opposite tacks, the boat with the wind on the starboard side has the right of way over the other. If they are reaching on the same tack, the boat to leeward, or farthest from the point from which the wind is blowing, has the right of way, and the windward boat, or the one nearest the wind must keep clear. If, however, the windward boat was in danger of going ashore, the other must give way upon being requested. If they are running directly before the wind, with main booms slacked well off, the boat which has hers over the port side is virtually on the starboard tack and has the right of way.

When one boat is overtaking another the overtaking boat must keep clear. The overtaken

boat must not, however, change her course after any part of the overtaking boat overlaps any part of her hull or rigging. A sailing vessel or yacht should have the right of way over a steamer or launch. It must be borne in mind, as in the rules for launches, that these rules are for guidance alone, and do not give the boat having the right of way any excuse for doing damage to an offending boat. It is also unwise for a small boat to attempt to enforce her right of way over a large boat; the small boat, being more easily handled, would best keep clear.

When sailing in a fog, a sharp lookout is kept, and the fog horn sounded:— When on the starboard tack, one blast at short intervals; when on the port tack, two successive blasts, and when running free, three successive blast. For night sailing the same lights, red on the port side and green on the starboard, may be carried, as described in the first chapter; no white light, however is carried. The same rules for judging of the position of an approaching boat apply as before, and right of way given as in sailing by day.

M. Verneuil has discovered the method of producing the ruby artificially by melting a mixture of alumina and oxide of chrome at a constant temperature of several thousand degrees, and in layers superposed from the outside to the inside, in order to prevent the production of cracks in the crystalline mass. The eminent chemist has succeeded in creating a ruby weighing about 2,500 grams and having a commercial value of about 3,000 francs. For securing the extreme temperature indispensable for the success of this operation, M. Verneuil had recourse to a vertical oxyhydrogen blowpipe, the flame of which was directed from above downward. The hardness of the stone was secured by an energetic tempering, suddenly suspending the action of the blowpipe. The ruby of M. Verneuil has admirable fluorescence, on account of its great purity. It possesses all the physical properties of the natural ruby, and like the natural ruby, can be cut and receive a very beautiful polish.

AMATEUR WORK.

DRAPER PUBLISHING CO., Publishers,

88 Broad St., Room 522, Boston, Mass.

A Monthly Magazine of the Useful Arts and Sciences. Published on the first of each month for the benefit and instruction of the amateur worker.

Subscription rates for the United States, Canada, Mexico, Cuba, Porto Rico, \$1.00 per year.

Single copies of back numbers, 10 cents each.

TO ADVERTISERS.

New advertisements, or changes, intended for a particular issue, must be received at this office on or before the 10th of the previous month.

Entered at the Post Office, Boston, as second class mail matter, Jan. 14, 1902.

SEPTEMBER, 1904.

Note the new address, 88 Broad St., Room 522,

In the office of a large manufacturing concern the editor was recently shown a letter in which the writer made application for a chance to learn the machinist's trade. The writing was poor, misspelled words abounded, and the grammatical construction was bad. This from a young man 17 years of age, who stated he had received a grammar school education.

The applicant did not receive the position, the refusal to give even a trial being based on the idea that anyone who cared so little about his ability to write a short business letter upon such an important subject, would in all probability not possess those qualities required to make a good mechanic. If the young men of today are to achieve success it can only be through a mastery of those things considered necessary for even the most unimportant positions and continued work and study until thorough knowledge is acquired of all that appertains to the work in hand or likely to be attempted.

In response to numerous requests from our readers, a book department will be opened in connection with this magazine, and we are now making arrangements to carry a stock of the more important and desirable books upon technical subjects. Any book published in the English

language will be obtained, upon order, at the lowest market price consistent with the conditions required for obtaining it. A list of those thought most desirable for our readers will be published at an early date. If the price of a book is not known by the purchaser, remit the amount thought necessary, together with postage, and any excess will be returned.

BOOKS RECEIVED.

THE MECHANICAL ARTS SIMPLIFIED. B. B. Dixon. Laird & Lee, Chicago, Ill. 8½x6 in; 497 pp. Flexible leather covers, \$2.50; cloth, \$1.50.

A mechanic, be he amateur or professional, cannot collect too much in the way of usable data, formulas, etc. This book contains a large number of tables, rules, formulas, as well as much general information of a usable nature, and will be found of value by all mechanics and electricians.

MODERN ELECTRICITY. James Henry, M. E. and Karel J. Hora, M. Sc. Laird & Lee, Chicago, Ill. 6½ x 5 in: 355 pp. Full leather, \$1.50; cloth, \$1.00.

While there are a number of books covering much the same ground as does this one, the different ways used by authors for presenting a subject give to each an appropriate value. In this one every effort has been made to simplify the expressions, without sacrificing the clearness or accuracy, so that the apprentice and artisan will be able to gain a complete knowledge of the fundamental principles and applications of electricity. The work will be found practical and accurate.

PRACTICAL POINTS. John S. Farnum, M. E. Laird & Lee, Chicago, Ill. 6x4½ in. 192 pp. Cloth. \$1.00

This is a handbook for engineers and mechanics, arranged in catechism form, giving questions and answers on practical subjects connected with boilers, engines and their parts and fittings; railroad and train signals, etc., together with much general matter connected therewith. The purchase of this and similar books is cordially commended.

VACATION PHOTOGRAPHY. No. 62 Photo-Miniature. Tennant & Ward, New York. 25 cents.

It is almost needless to say that anything published in this series is valuable to the photographer. This is no exception, and contains many practical pointers for those about to go a vacationing. Money spent in preliminary study upon this subject means a greater saving in supplies, to say nothing of the better work resulting.

DESIGN FOR A LIGHT GASOLENE CAR.

J. C. BROCKSMITH. M. E.

Reprinted by Special Arrangement with the American Electrician.

The accompanying working drawings illustrate a type of gasolene automobile which is about as light and simple in construction as such a machine can be made consistent with the reach of the amateur builder and automobile enthusiast. The well-known arrangement of "motor in front, sliding gear transmission, and bevel gear drive" has been adopted as representing the best practice for light cars. Fig. 1 is a side elevation of the complete machine, which shows the general arrangement and appearance of the car.

The motor is a two-cylinder vertical machine of the two-stroke cycle type; it is air cooled and located under a well ventilated bonnet in front. The motor has an output of 6 horse power at the normal speed of 750 r. p. m. The power is transmitted through a cone clutch in the fly-wheel to the transmission gear which provides forward speeds of 6, 12, and 25 miles an hour and one reverse speed of 6 miles an hour, all at the normal motor speed of 750 r. p. m. It will be understood, however, that any intermediate speed can be obtained by the usual methods of shifting the spark and throttle control. The rear axle is driven through a universal joint and bevel gear, the latter being enclosed in the same case which contains the differential gear.

Steering is effected by means of a hand-wheel operating a screw and nut and is of the "irreversible" type; that is, no inequalities in the road can work back through the steering linkage and produce a motion of the hand-wheel. Upon the steering column are also mounted the spark and throttle levers, by means of which the speed of the motor is controlled. The machine is further controlled by means of the clutch release and brake pedals which are seen protruding above the inclined footboard. The gear is changed by means of the lever shown alongside the seat on the right-hand side. When changing from one gear to the next the clutch pedal must, of course, first be depressed, thus disengaging the motor from the transmission, so that no power is passing through the gears and they can be brought into mesh without danger of stripping the teeth.

The brake acts on the secondary shaft of the change gear, and being geared up to the rear axle in the ratio of 4 to 1, a very powerful breaking effect is obtained with a moderate size of brake drum and a comparatively light pressure by the brake.

The gasolene tank is located directly under the seat and is filled through the cap shown in the top, which can be readily got at by removing the seat cushion.

The wood work of the seat is of the simplest possible

description, only straight boards being used; the curved surfaces usually seen on automobile bodies would probably be out of the question for anyone who wished to construct the woodwork himself.

The body is hung on three springs, a semi-elliptic spring being used in front, while the rear springs are full elliptic. The wheels are 28 in. in diameter, have wooden spokes and are equipped with 3-in. detachable pneumatic tires. Fig. 3 is an end elevation of the complete machine, which brings out a number of dimensions and points of construction not clearly indicated in Figs. 1 and 2. The front spring is a 38-in. 5-leaf semi-elliptic spring fastened at its extremities to a pair of short links to allow for extension, and at the centre is bolted to a wooden cross-bar which is shaped to fit the curvature of the spring and which supports the frame and body of the vehicle. The front axle is given a drop of $1\frac{1}{2}$ in. below the centre line of the wheels in order to give additional room for deflection of the springs and thus prevent the motor shaft from striking the axle.

This view also shows a section of one of the wheels, which brings out the construction of the hub and the form of the rim and tire, the latter two being of standard section and dimensions. The construction of the seat is also indicated in the view; it will be noted that the sides are inclined outwardly and come inside the flanges of the angle iron frame at the bottom, being fastened thereto by means of screws. The steering column is shown on the right-hand side of the machine, as this side is considered in common practice to be the best for operating the machine.

Fig. 2 shows a plan view of the chassis. This shows all the operating parts in their proper relation and is probably the best drawing to work from in assembling the machine. The frame is composed of two lengths of 2 in. x 2-in. x 3-16-in. angle steel, each 84 inches long. Across the front is bolted a piece of 2-in. ash which is shaped to fit the spring; $\frac{3}{8}$ -in. carriage bolts may be used for this, and a washer should be used under the nut to prevent it from cutting into the wood. Bolted to the under side of this cross-piece in front are two longitudinal frame members of 2-in. x 2-in. ash, to which the motor and change gear case are bolted. The rear ends of these longitudinal members are supported by a 2-in. x 2-in. cross-piece, which is in turn bolted to the bottom flanges of the angle-iron frame. The clutch release and brake pedals, it will be seen, are swung on rods attached to the wood frame members. The curved connecting link which moves the sliding gear shifter and connects with the hand lever

FIG. 1. SIDE ELEVATION OF COMPLETE MACHINE.

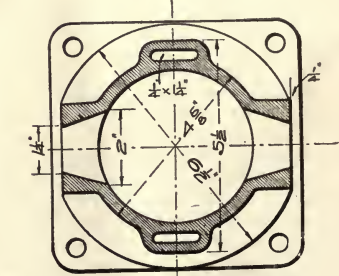
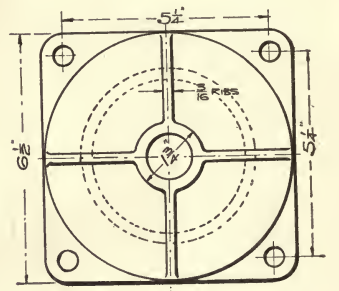
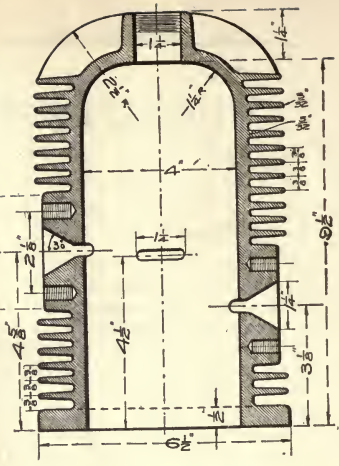
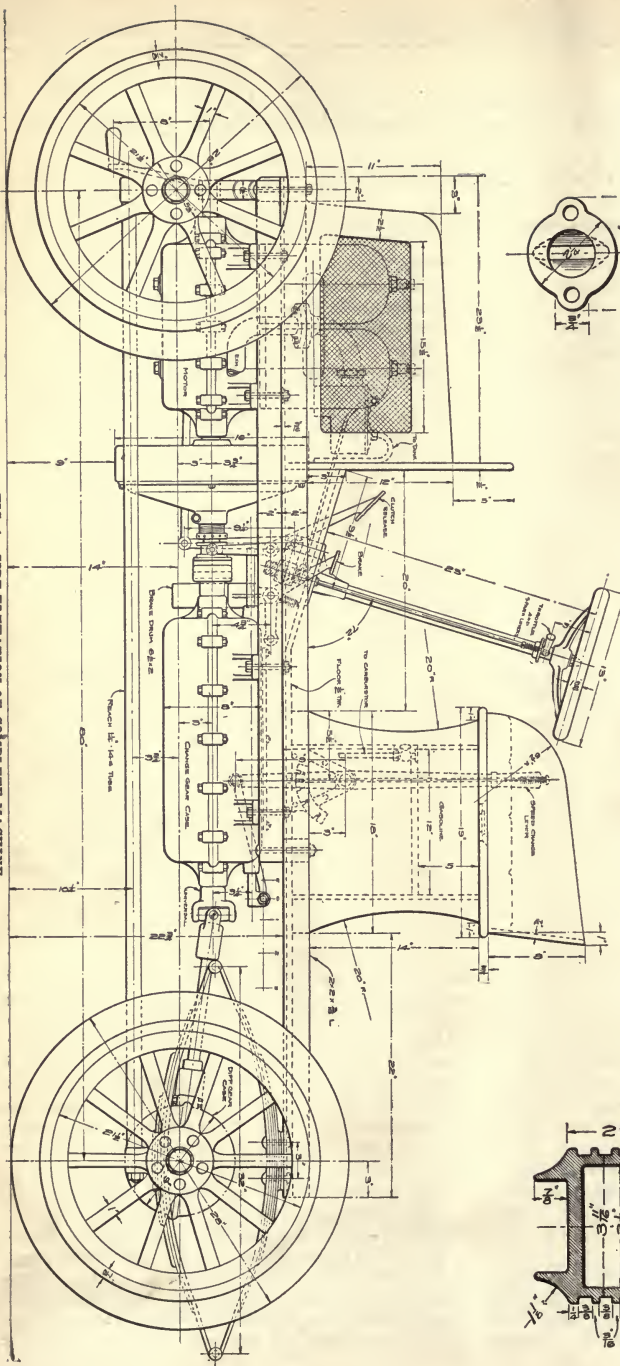

FIG. 6. DETAILS OF CYLINDER.

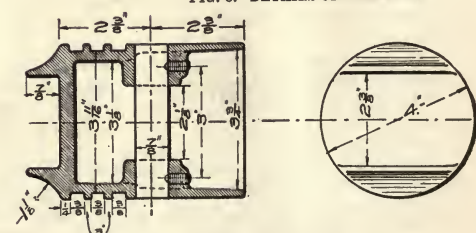

FIG. 7. DETAILS OF PISTON.

FIG. 8. DETAIL OF CONNECTING ROD.

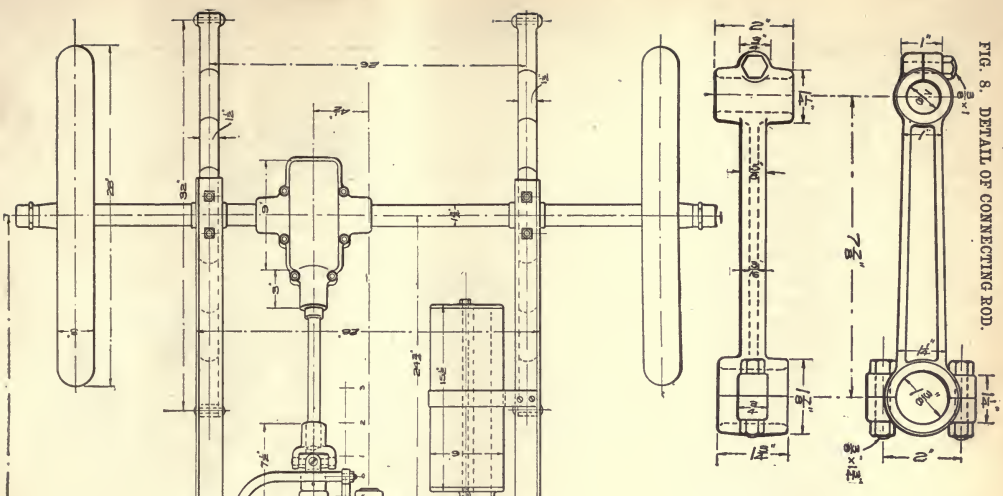

FIG. 9. DETAIL OF CRANK SHAFT.

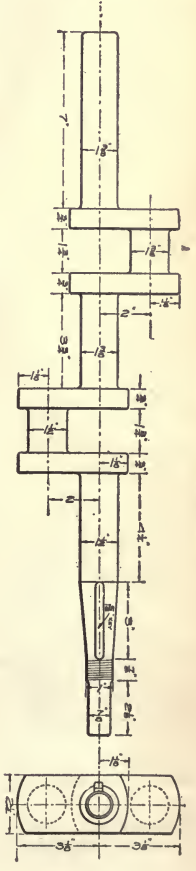
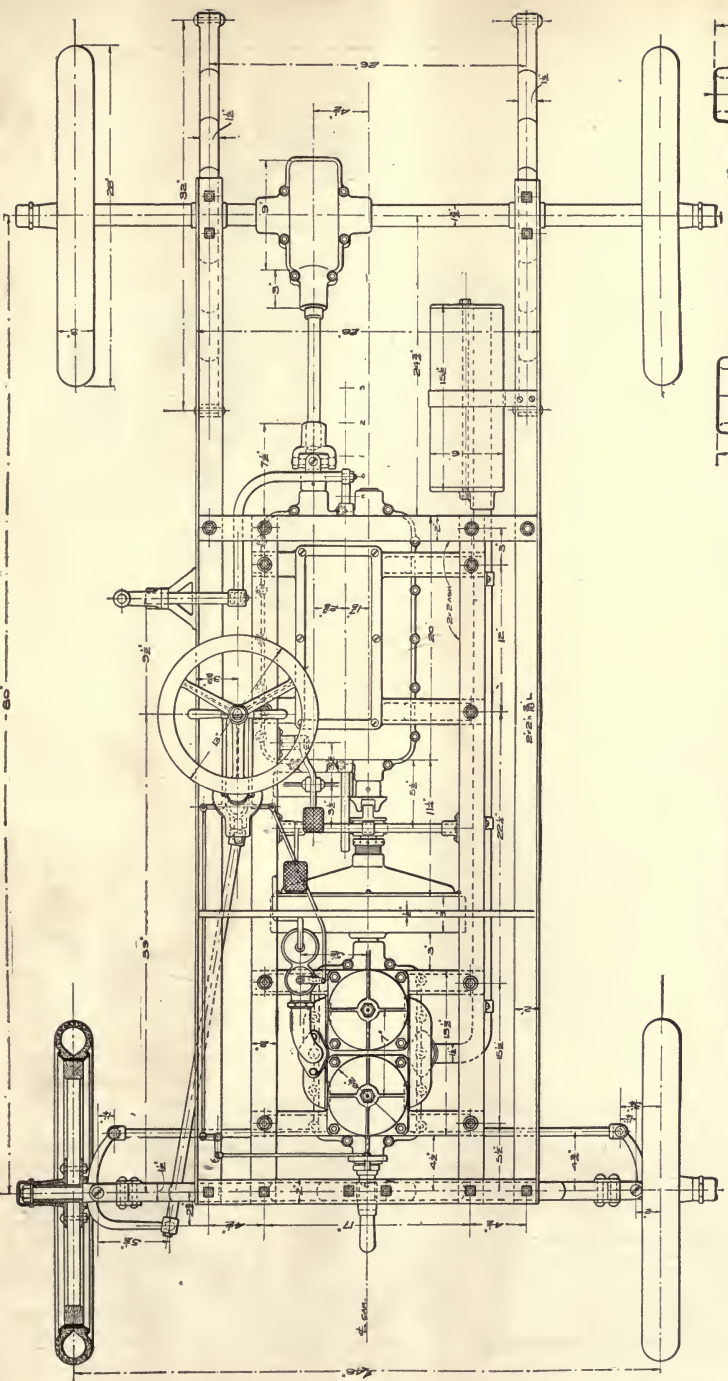
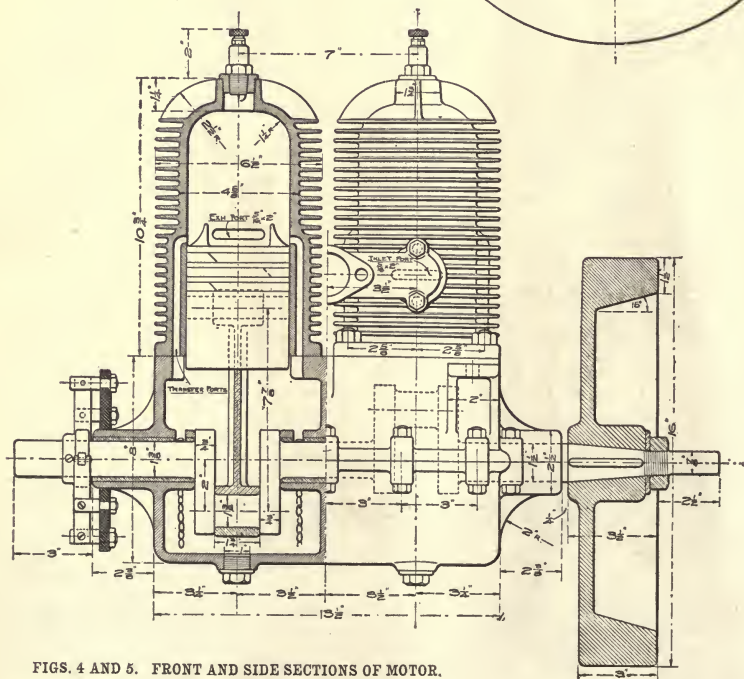
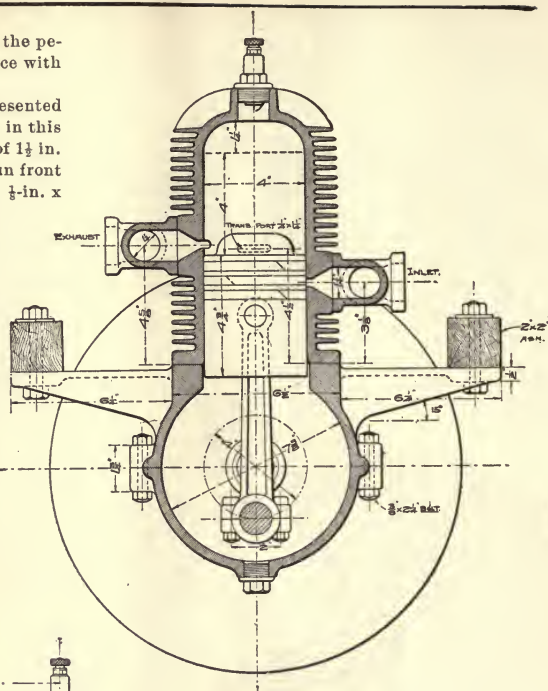

FIG. 2. PLAN VIEW OF CHASSIS.



is clearly indicated in this view. It is made of the peculiar shape shown in order to avoid interference with the frame members.

The exhaust pipe and muffler, which are represented as broken away in Fig. 1, are shown in position in this view. The exhaust pipe consists of a length of $1\frac{1}{2}$ in. steel tubing, bent to suit the frame members in front and fastened thereto by means of small clips of $\frac{1}{4}$ -in. x 1-in. iron. The muffler is simply a hollow sheet metal cylinder, with cast heads bolted in by means of a through bolt and perforated with numerous small holes on the under side; the aggregate area of the perforations should be about equal to the area of the exhaust pipe in order to avoid undue back pressure. It is probable that a length of common 6 in. stove pipe will answer for the cylindrical part. If this is found to have an undesirable amount of resonance it may be wound with wire, which will stop the vibration of the walls and will also help to strengthen them. It will probably be necessary to have a cross member in the frame at the extreme rear. The frame is left long in the rear to allow for the addition of tonneau seats if the builder finds them desirable.



FIGS. 4 AND 5. FRONT AND SIDE SECTIONS OF MOTOR.

TOOL MAKING FOR AMATEURS.

ROBERT GIBSON GRISWOLD.

II. A Set of Cold Chisels.

In our first chapter we considered briefly the forging of a set of light hand tools, and in this chapter we will extend this set to that of a series of cold chisels of various sizes and shapes, such as will be most useful and convenient for the work generally pursued by the amateur.

The steel of which cold chisels are generally made is special and octagonal in shape. This octagonal shape is convenient in forming a grip for the hand to prevent twisting when struck with the hammer. When the steel is purchased at the jobbers they can give information as to the grades, which are so great in num-

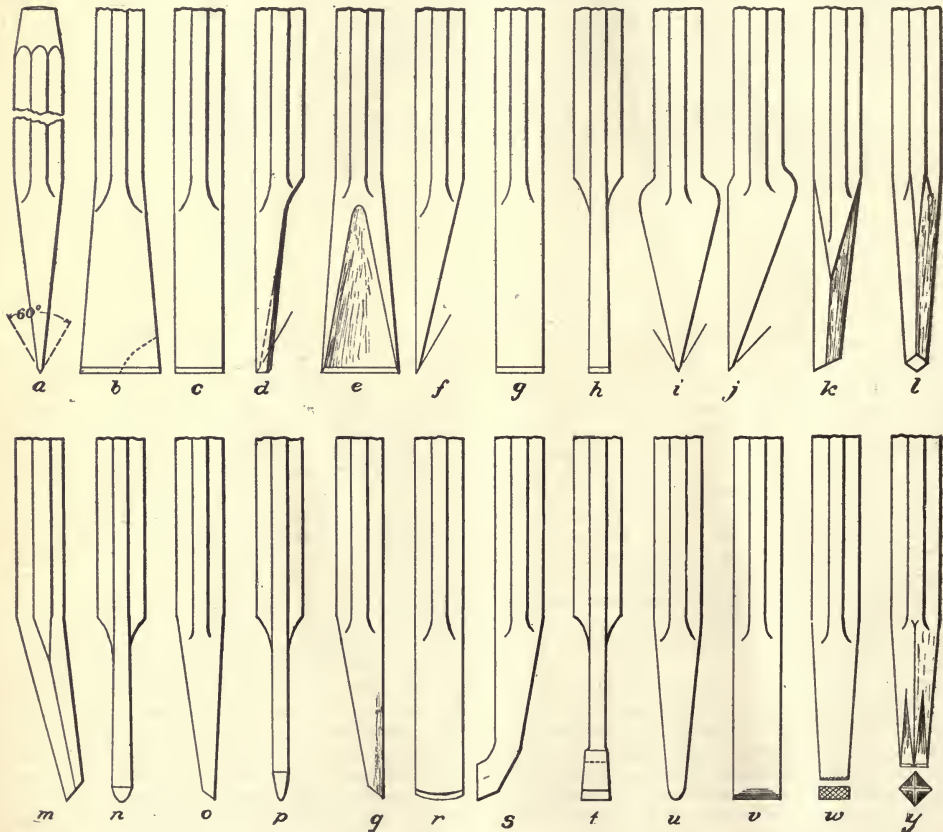

A good working set of cold chisels should comprise quite a number, for they bear the same relation to work in metals as the carpenter's chisel does to wood-work, and for the same reason that a variety of shapes and sizes of the latter tools prove expeditious in work, so will a variety of cold chisels prove very useful in all classes of work in metals.

ber and constantly changing that it would hardly be possible in this article to describe them. Old files make excellent chisels when properly treated, and they stand up to their work admirably.

The character of the work determines largely the width of the cutting edge, and for this reason a number of cutting sizes will prove acceptable. When cut-

ting hard metals, such as cast iron and steel, heavy blows must generally be struck, and a narrow chisel would not stand it long without cracking on the edge, while with the softer metals, such as copper, brass and babbitt, lighter blows should be struck to prevent the metal breaking and crumbling before the chisel, this rendering the cut rough and uneven, and narrower tools are generally used for this work. But even the above rule cannot always be used for more than a guide. The thickness of the cutting edge and its angle play equally important parts, as will be spoken of later on, and the experience and judgment of the workman must be relied upon to some extent.

In Fig. 1 is shown a number of chisels shown by *a*, *b* and *c* in the form most commonly used for general work. The head should be forged down as shown so that "brooming" will to some extent be prevented. A very convenient length is five inches from head to edge, with a gradual taper from the body to the edge, as illustrated. The cutting edge is ground to about 60°, although it ranges from 45° to 75°, the blunt angles being given to the tool when used on heavy work. The flat chisels should be made in a set as follows: $\frac{5}{8}$ in. $\frac{3}{4}$ in., $\frac{7}{8}$ in., and 1 in. in width.

When the tool is forged the edge only must be hardened for about $\frac{1}{4}$ in., the metal above being left softer to withstand the shock. When the tool is left hard too far up a heavy blow will cause the thin point or edge to crack off on a line, as shown by the dotted line on *b*. Draw the temper to a light purple for steel and a dark purple for cast iron and wrought iron work.

A set of gouges as shown by *d* and *e* should be made in the following sizes, $\frac{1}{2}$ in., $\frac{3}{8}$ in., $\frac{1}{4}$ in. and $\frac{3}{16}$ in. The bevel is ground on the concave side and flat on the convex side. The gouges are used for cutting grooves and fillets.

A chisel made as in *f* and *g* is very useful and is called a side chisel. The edge of the chisel coincides with a flat side, thus enabling thin paring chips to be taken from the inside of a slot or square hole, which could not be done very well with the ordinary flat chisel. These chisels should be made in three sizes, $\frac{1}{2}$ in., $\frac{3}{8}$ in., $\frac{1}{4}$ in.

The chisels shown in *h*, *i* and *j* are known as the cape chisels and are used for cutting grooves. The point is made the width of the groove and the stock behind is made slightly thinner to give clearance. Two sizes, 3-16 in. and $\frac{1}{4}$ in. are sufficient. The shape *j* is very handy in cutting the ends of key ways square. It is practically the same as a $\frac{1}{4}$ side chisel of form *f* but it is much stronger.

The diamond point chisel *k* and *l* is used for cutting sharp corners, V grooves and lettering. Only one size is necessary, the side of the square being about $\frac{1}{4}$ in. It should not be ground to too keen a point, as it is easily broken when not well supported. When a diamond point is bent as in *m* it can be readily used on a flat surface.

Two round-nose chisels are shown at *n*, *o*, *p* and *q*. The form *n* is used for heavy work, and $\frac{1}{4}$ in. and $\frac{1}{8}$ in.

are sufficient. The form *p* is lighter and is used as a drawing chisel for drawing a drill when it runs out of true. It is simply a round-nose chisel with a very long taper and small radius.

It is often necessary in fine work to remove only a very thin chip. If the ordinary flat chisel is used the corners will leave ugly cuts on the surface. The chisel is then ground slightly as in *r*, which keeps the corners in sight at all times, and very thin chips can be taken.

The form *s*, *t* is useful in cutting keyways in small holes, as the body of the chisel is kept away from the work and clean cuts can be made. The forms *u* and *v* show a caulking tool with a round nose, and at *w* is a tool with a serrated face, useful in peening out small surfaces, heads of rivets, etc., which are too thin to stand heavy peening. The face is provided with teeth by filing diagonal slots before hardening.

The tool *v* is made for splitting rivets before finally peening flat. It spreads the rivet quickly and requires only a light blow.

If the amateur provides himself with a set of tools he will be in a position to work quickly and expeditiously and the work need not suffer for want of the proper tools. Our next installment will treat of a set of lathe tools.

There are several photographic methods of making lantern slides of drawings and diagrams, of which the wet-plate process is, perhaps, the best; but recently it occurred to me to try a simple method, which has given most satisfactory results, though I do not remember to have seen it suggested elsewhere. All that is necessary is to draw or write with a hard pencil—a 6 H for choice—on ground glass squares $3\frac{1}{2} \times 3\frac{1}{2}$, of as finely ground glass as possible, then to flood the ground side of the glass with dilute Canada balsam in xyl or benzol. Cover with an ordinary lantern-slide covering glass, and bind in the usual way. The glasses must, of course, be first carefully cleaned. The result will be that the ground glass is made transparent while the pencil lines become more distinct.—*F. S. Scales.*

One result of using very short focus lenses, points out *Photography*, is that the illumination falls off rapidly as the margin of the plate is approached, a fact that may not be suspected at first, but which will make itself painfully visible as soon as a case occurs when the exposure has been full short. This is partly due to the lens. By measuring the actual proportion of the light falling upon the edges and the centre of the plate respectively, it would be found that while the difference in the quantity of the incident light is considerable, it is less than the difference in its photographic action. Comparatively little of the light that falls upon or near the centre of the plate is lost by reflection; but as the rays approach the edges, reflection becomes greater, and a very small proportion of them are available for useful work in the plate.

A BENCH GRINDER.

B. R. WICKS.

Continuing the work of machining the bench grinder, lay out the boss for the bearing of rest No. 1 central with the boss and square with the spindle bearing, and drill and ream to $\frac{1}{2}$ in. diameter. The front of this boss can be faced off with a counterbore and filed and polished, but this is only done for looks.

The two bosses on the back of the spindle bearing, which are for the spindle adjusting screws, are to be laid out, drilled, counterbored and tapped. When the centre of the bosses have been located and centre punched, first drill all the way through with a 3-16 in. twist drill. Have at hand a counterbore with a $\frac{5}{8}$ in. body and 3-16 in. pilot and counterbore down to the depth of 3-16 in. Enlarge the 3-16 in. hole to the depth of $\frac{1}{2}$ in., with a 17-64th in. twist drill, and tap out the remainder of the 3-16th in. holes with a $\frac{1}{2}$ -20 thread tap, as in section C-D on drawings.

The 1-16 in. slot for the take-up piece and the oil groove will be put in after the spindle, B, has been turned and fitted, which will come later.

The $\frac{1}{2}$ in. boss on the top of the spindle bearing is to be drilled all the way through to the 9-16 in. boss with a $\frac{1}{2}$ in. twist drill and enlarged with a No. 1 twist drill to the depth of $\frac{5}{8}$ in. and tapped out with a $\frac{1}{2}$ in.-32 V thread tap for an oil cup.

There must be a $\frac{5}{8}$ in.-16 thread tapped hole in the side of the frame, central with the thickness of the casting and exactly central with the $\frac{1}{2}$ in. hole in the boss, to hold the set screw, K, which holds the rest No. 1 E, in position when the machine is in use.

Tap this hole $\frac{5}{8}$ in.-16-thread U. S. S. and use a 5-16 in. twist drill for the tapping size. L is the shoe that works against the $\frac{5}{8}$ in. flat on rest No. 1, E, to keep it in position, and also to avoid screw K from cutting in the $\frac{5}{8}$ in. flat on rest No. 1, E. This rest is made of a piece of 19-64 in. brass rod and cut off and finished to 3-16 in. long, and placed in the $\frac{5}{8}$ in. tapped hole when the machine is ready to put together. Screw K is a regular screw cut off and hardened to the figures given on the drawings.

The spindle, B, is made from a piece of round machine steel 6 15-16 in. long and 15-16 in. diameter in the rough, and is drilled, centred and turned up between centres to the figures given on the drawing. Both the $\frac{1}{2}$ in. and 9-16 in. diameters of the spindle must be turned exactly straight, and true and smooth for good results from the machine. Allow enough on both diameters to file and polish, and fit the spindle to the 9-16 in. reamed hole in the frame, A, which forms the spindle bearing.

After filing the spindle, finish with fine emery cloth and oil using, as before stated, the 9-16 in. hole for a gage. The thread on the end of spindle B can be cut in the lathe, but if the builder has not a screw cutting

lathe it can be done with a die. The die stock should be provided with a $\frac{1}{2}$ in. guide to insure a straight thread.

The thread to be cut on spindle B is $\frac{1}{2}$ in. 13-thread U. S. S. 1 $\frac{1}{2}$ in. long, right hand. There is one $\frac{1}{2}$ in. 13-thread semi-finished nut wanted which should be case hardened.

The two wheel flanges, D, are made from grey iron castings, and are to be chucked, centred, drilled, reamed and turned. The flange that fits against the 3-16x $\frac{1}{2}$ in. shoulder on spindle B must be bored out a little less than $\frac{1}{2}$ in. the diameter of the flange end of the spindle to allow for a shrinking fit. After having bored out this flange force it on a mandrel and turn the back face that will fit against the shoulder on the spindle true. The remaining part make about 1-32 of an inch larger than the drawings. Heat this flange to a good cherry red and tap the spindle into the hole and be positive that the face of the flange and the face of the 3-16x $\frac{1}{2}$ shoulder on spindle B come up tight together; let it cool off (do not put it in water). When cooled put the spindle between centres and finish up the flange to the drawings and polish with emery cloth and oil. The other flange is bored so that it will slide on the spindle, and finished up in a $\frac{1}{2}$ in. mandrel to the drawing. When in the chuck do not neglect to put in the recess 3-64 in. deep.

The pulley, C, is made from a grey iron casting. Chuck the casting and drill and ream out to 9-16 in. diameter; force it on a 9-16 in. mandrel and turn up to 2 in. diameter. Face the two sides of the rim, making it 1 $\frac{1}{8}$ in. wide. Face up the hub $\frac{1}{2}$ in. from the rim on each end, making it a total length of 1 $\frac{1}{2}$ in. The pulley will now be crowned from 2 in. in the centre to 1 15-16 in. on the sides, as in the drawing; file, and polish with emery cloth and oil. There will be two $\frac{1}{2}$ in. 20-thread tapped holes to be made in the hub for the two $\frac{1}{2}$ in. 20x $\frac{1}{2}$ in. headless set screws, J, which will hold the pulley C in position on the spindle, B. Lay these holes 5-16 in. from the rim and central with the diameter of the pulley, and centre punch mark and drill all the way through the rim and hub with a 3-16 in. twist drill, and tap out the 3-16 in. holes in the rim only with a 3-16 in. twist drill. Enlarge the holes in the rim only with a 17-64 in. twist drill and tap out the 3-16 in. holes in the hub with a $\frac{1}{2}$ in. 20 thread U. S. S. tap. The two set screws, J, are regular sizes and will not have to be made up by the builder. Two of these screws are wanted.

The rest, No. 1, E, is made from a piece of 11-16 in. square cold drawn steel, 4 15-16 in. long.

NOTE. The drawings and previous portion of the description appear in the AUGUST number.

Polish off the side of the steel, rub on a little blue vitriol and lay out the 7-16 in. hole for the rest, No. 2, *F*, to work in. Prick punch where the lines cross and start in with a small drill, about $\frac{1}{8}$ in. or so, and drill all the way through. Then drill with a 28-64 in. twist drill, and finish out with a 7-16 in. lathe reamer.

The piece will now have to be centred; take it from corner to corner and drill and countersink, and between centres turn the $\frac{1}{2}$ in. diameter that is to fit into the $\frac{1}{2}$ in. reamed hole in the boss on the frame, *A*. This must be turned straight and smooth to the length of $\frac{1}{4}$ in., leaving .002 to file and finish with emery cloth and oil. It must fit the $\frac{1}{2}$ in. hole and slide in and out without any shake. The flat on the side is $\frac{3}{8}$ in. wide 3 13-32 in. long, and can be either milled or filed. Do not fail to notice the location of this flat with the 7-16 in. hole.

The end can be finished up between centres with a round pointed tool. The $\frac{1}{2}$ in. hub on the 11-16 square end is now drilled into the 7-16 in. hole with a $\frac{1}{2}$ in. twist drill, and tapped out with a 5-16 in. 18-thread U. S. S. tap. The four sides can be draw filed and polished with emery cloth and oil.

The rest, No. 2*F*, is made from the same stock and machined in the same way. The only exceptions are the length, diameter, and the set screw to be used in the end. The 7-16 in. diameter of rest No. 2, *F*, fits in the 7-16 in. hole in rest No. 1, *E*, and must be a good sliding fit without any shake. The 11-16 in. square end is drilled with a 3-16 in. twist drill and tapped out with a $\frac{1}{2}$ in. 20-thread, U. S. S. tap.

There will be one of each of the screws shown on the lower right-hand corner of the drawing. These are to fit the ends of rests No. 1, *E*, and No. 2, *F*, and are made from regular set screws cut off to the figures given on the drawings, and the heads drilled in and hardened. The drawings show the position of these screws when the machine is assembled.

The tool rest, *H*, is made from a grey iron casting and is laid out by the 9-16 in. boss on the bottom of the castings, and drilled and reamed out to 5-16 in. diameter, forced on a short mandrel and faced up $\frac{1}{8}$ in. thick. The under part does not need to be machined. The 5-16 in. hole is slightly countersunk so that the tool rest spindle, *C*, can be riveted in. The tool rest spindle, *G*, is made from a piece of $\frac{3}{8}$ x 2 7-16 in. Bessemer steel. One end must be turned down to drive in the 5-16 in. hole in tool rest, *H*, and be riveted, draw filed and polished on the top and edges.

The remaining work to bedone will be to put in the oil groove, saw the bearing through with a 1-16 in. saw, make the spindle adjusting piece, paint and assemble. The oil groove in this case can be filed in with a $\frac{1}{4}$ in. rat tailed file, starting in on one end and then turning the piece end for end until the groove is made. To saw out the 1-16 in. slot a milling machine will have to be used. Set the casting in the vise by the two finished ends of the spindle bearing and set the 1-16 mill exactly central with the 9-16 in. hole and central with the thickness of the two bosses, as in section *C-D* on the

drawing, slowly feed in the saw and cut the 1-16 in. slot all the way through. Remove from the vise and with a fine half round file, file out the burr left by saw.

The spindle adjusting piece is not shown on the drawings. It is made from sheet brass 1-16 in. thick. Take the piece of brass, file off any burr that may be on it and slide it into the slot within 1-32 in. of the spindle on each end, mark around the casting and locate the two 17-64 in. holes with a sharp scratch. Now remove and drill the two holes with a 17-64 in. drill, file down to the lines and the piece is done. Make the length of the piece about 2 15-32 in. long. The adjusting piece can now be replaced, and the two spindle adjusting screws which have been made and hardened screwed in their places in the bosses.

The spindle, *B*, can now be placed in position in the bearing. Screw down the two adjusting screws on both ends until the spindle will turn freely in the bearing without any shake. If the adjusting piece proves to be too thick to get the proper adjustment it will have to be taken out and draw filed until the proper adjustment can be obtained. The only remaining work is to assemble the various parts and paint or enamel the machines. As all the parts are named and the bearings clearly show how and where these parts are to go, there should be no trouble in assembling and putting the machine in operation.

ABOUT PATENTS.

When to be Obtained and How Developed.

Whether because of the stories of immense fortunes to be made through patents, or the natural product of the fertile ingenuity of the people of this country, it certainly is a fact that an immense number of patents are yearly granted by the patent office at Washington. It needs but a hasty perusal, however, of that bulky weekly volume, the Patent Office Gazette, to show to the experienced and educated mind that large numbers of these so-called inventions are destined to quickly sink into oblivion, leaving behind them no other record than that above mentioned, of the time and money expended, and the probably accompanying dreams of future fortunes forever blasted. Because it is certainly true that most of the patents are secured by inventors actuated by a desire to profit quickly and in a large measure from the devices their minds have created. It is also undoubtedly true that many of these inventors have devoted much time and money badly needed for family necessities to perfecting their inventions, which were bound from their nature to have little or no commercial value, and so procure no return for the sacrifices made.

While in no wise wishing to discourage meritorious invention, it is hoped that what is here stated will be helpful to readers and prevent those of an inventive turn from repeating the mistakes and suffering the losses which are, unfortunately, so frequent at the present time.

A few words about inventions in general. Excluding those which are secured by paid employes of manufacturing concerns to protect or improve the control by such concern of some process or machine already owned by them, the majority of patents otherwise granted are obtained with the expectation that the inventor will secure direct and liberal financial returns therefrom.

Under what conditions is this expectation likely to be realized? Among these conditions may be mentioned that the article be one for which sufficient demand already exists, or a reasonable certainty that such a demand can be created, to warrant its manufacture. This is often a most difficult matter to decide, and expert opinion may vary widely. Not many years ago an inventor offered to sell a manufacturer the patent for a small pin for \$750, but the offer was declined. Within a year the same manufacturer had paid in royalties over \$1100 for the right to use the pin, which was not an exclusive right, or considerably more than the sole ownership would have cost.

Another important condition is that the cost of manufacture of an article shall be within the limit which will permit of its being sold at a satisfactory profit, or permit of its being sold in competition with existing devices. The non-refillable bottle is a good illustration of the above condition. It has been pretty generally reported that a fortune awaits the inventor of a successful non-refillable bottle. Perhaps this is so, but whether it is or not, it certainly is a fact that of the hundreds of patents granted on devices for this purpose, few of them could be manufactured at a cost that would permit of their being generally used, and many of them would be so expensive as to immediately settle the question of their use in the negative. If the inventor had but consulted a competent business man or manufacturer before going to any expense for a patent, the impracticability of the invention would have been made clear to him.

Admitting that there is some merit to an invention, there still exists the question: Can a sufficient sale be developed, without too much expense, to promise a satisfactory profit. In this class are many devices intended for use on street and steam railways. At once is met the great difficulty of securing a trial by a railway of sufficient size so that approval brings commercial standing. Influential friends may be of some value in securing a trial, but more generally this counts for but little. The officials of the large systems are importuned continually by inventors, and a device must possess evident merit to secure a proper trial. A good way to give an invention of this class standing is to interest a small road to allow a trial to be made, and if satisfactory results follow, the larger ones can then be more easily prevailed upon to give trials. But no railroad, large or small, will expend money on an untried or unnecessary device. By unnecessary is meant anything which they can get along without, unless a sufficient saving is effected to make its purchase and use economical. The engineer of one large

railway always tells inventors or promoters of untried devices that his road is willing to let others do the experimenting, and they will pay the increased price for the perfected article when they find they have got to have it.

From this brief presentation, it should be evident that the commercial conditions are quite as important as the mechanical ones, and should receive quite as thorough an investigation before time or money is invested in inventive work. If this idea was more generally followed, many patent agents would be obliged to seek other fields of labor, without any great loss to the public, and with considerable saving to many whose visionary ideas or impracticable friends have led them to secure one more foolish patent.

Assuming that a device has merit, is original, and that a promising field awaits the granting of the patent, the value of a patent then depends to quite an extent upon the broadness of the claims. A patent attorney who is working for the best interests of his client, endeavors to have the claims made as comprehensive as possible, many times expecting the first application to be returned for revision or the elimination of some one claim or more, clinging persistently to as much as possible, and conceding slowly only what is necessary to finally secure the patent. Of course such services are expensive and not given by "job lot" firms who obtain patents on the first application simply because the claims are so restricted that no conflicts are likely or desired. Such patents have little or no value for that very reason. An invention must indeed be novel if it does not in some way touch upon the ground covered by another, and skill and care are needed to preserve a strong and valuable patent.

In conclusion, it may be stated that inventors are not usually very good business managers and had best leave the business end to others. The fear of being tricked out of just returns is an ever present one with inventors, but considering the number of failures made by those who attempt to finance their own inventions, the chances of success are decidedly in favor of those who are wise enough to secure the services of a reliable and competent business man; the combined team of inventive and commercial ability being a strong one and likely to achieve success if success be possible.

Many large manufacturing concerns will not today consider the purchase of an invention unless a price so low as to make the risk of loss a small one. They will, however, give careful attention to anything with merit on a royalty basis, and to most inventors this is by far the best arrangement possible. The business skill, established trade and reputation of the firm are immediately made available to place the invention before the trade, and sales are then being made and profits realized before any inventor, thus unaided, could have got properly started. By this arrangement the inventor shows his own faith in his invention, and in the majority of cases will secure as large or larger returns than when managing the business himself, because of the better facilities for developing the invention.

JUNIOR DEPARTMENT

For the Instruction and Information of Younger Readers.

ELEMENTARY MECHANICS.

J. A. COOLIDGE.

VIII. Buoyancy.

That bodies heavier than water sink, and if lighter than water float, is a fact so well known as to make any such statement unnecessary. Yet the relation these bodies bear to water and other liquids and the cause of a body's sinking in one liquid and not in another afford us opportunity for valuable experiment and additional knowledge.

If a stone or other body falls through the air or sinks in water, it is because a downward force called gravity pulls it, and every body will move downward, *i. e.*, towards the earth's centre, until something prevents further motion or, better, until the force pushing upward balances the force downward. The downward force we call the weight of the body. In every floating body we call the force holding it up, the buoyancy. A few experiments will teach us some interesting facts about buoyancy.

Let us make first two blocks 2x3x3 in. and a little box of $\frac{1}{2}$ in. stock that will just hold one of these blocks. See Fig. 23. The box and the block may be of pine and should be coated thoroughly with melted paraffine, which may be obtained from a common candle. The wax will make them waterproof. A large glass jar 10 in. deep and 6 in. in diameter will be a great convenience, although a deep pan or pail will answer.

EXPERIMENT XIX.

Take the box and block to a grocer's or provision store and weigh them as accurately as the scales will allow. If you know some druggist who would help you weigh them to 1-10 oz., the experiment would be more successful. Fill the box with cool water and weigh again. The box and the blocks, if accurate in measurement, contain just 18 cubic inches in volume. By dividing the weight of the block by 18 you will have the weight of 1 cubic inch of wood. This will be the density of this wood. From the weight of the box filled with water subtract the weight of the empty box and divide this figure by 18 and you will find the density of water, which is about .58 of an ounce per cubic inch. Commonly 62.5 pounds is allowed as the weight of a cubic foot of water.

EXPERIMENT XX.

Float the box in the jar of water and measure carefully the depth that it sinks in water. If one corner sinks more than another, all four corners should be measured. Calculate the volume, ABCD, under wa-

ter. See Fig. 24. This will be the amount of water displaced. Find the weight of this water, allowing .58 oz. for every cubic inch. Does it not equal the weight of the box? It should, for every floating body displaces its own weight.

EXPERIMENT XXI.

Take a tin vegetable can, measure its diameter. Calculate the size of the bottom by multiplying radius x radius x 3.14. Put some sand in the bottom and make it float vertically. Measure the depth under water.

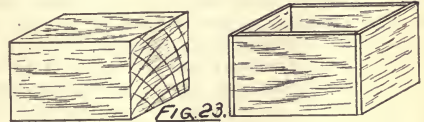

FIG. 23.

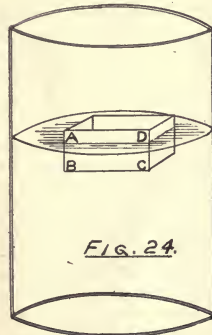

FIG. 24.

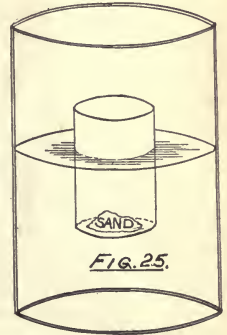

FIG. 25.

The volume of water displaced will be the area of the bottom multiplied by the depth under water. Find the weight of this number of cubic inches of water by multiplying this volume by .58 oz. Weigh the can with the sand in it. Of course you know that the hollow can floats because, although of heavier material than water, it displaces its own weight, and by sinking deeper in the water it would still float and hold more sand inside. See Fig. 25.

These two experiments show how a wooden ship, and even one made of steel and iron, floats while holding an immense cargo. A vessel made of iron or steel, although of material seven times as heavy as water, has large airtight compartments, so that buoyancy is sufficient to float ship, passengers, cargo, and many other things. I have in my hands the description of one of the great ocean steamers, not the largest, yet in itself a floating city. Try with me to get some concep-

tion of her size. She is 580 ft. long. Pace off 200 of your own steps and see how far you have gone and you will have some idea of the length. It would take you two minutes to walk from bow to stern. In a town or city where lots have 50 feet frontage this vessel would, if placed in the street, pass by eleven houses. She is 62 feet wide and would fill many an ordinary street from side to side, touching the houses on both sides. She is 45 feet deep. We could stand in the third story window of our houses and look up to the deck of this boat, or step from the deck to the roof of a five storied building. She weighs 13,000 tons empty, and will carry 12,000 tons of cargo. She carries about 800 single loads of coal just for her own use and, although floating in an ocean of water, carries over 2000 tons of fresh water on board. Over 1,000 people find every accommodation for a long cruise, as many as are found in many small towns, and all are comfortably housed and fed. Every modern convenience, electric lights, baths, ice, fire alarm and apparatus is found on board. She makes her own ice and carries apparatus for evaporating fresh water from salt, enough to make 40 tons every day. Immense engines and shafting over 200 feet long and 16 inches in diameter, of 9,000 horse power, drive this immense floating palace through the water. Can you not see how important it is to know about the buoyant effect of water in order to provide for floating such a vessel?

The effect of salt water as compared with fresh in its buoyancy, can be studied with profit.

EXPERIMENT XXII.

Take two jars or pails. Fill them both with fresh water. Now take an egg, hold it in the water and let go. It will sink. In one of the jars put a handful of salt and stir. If the egg still remains on the bottom, put in more salt. While this experiment is going on take one block and float it in fresh water, then in salt. In each case notice the depth to which it sinks. With a good deal of salt in the water the egg may be made to float, and the block floats with much less under water than before. In an ocean of salt water a vessel sinks less deep than in fresh because the displaced water is heavier and, therefore, the buoyancy is greater. We see, then, that heavy liquids are more buoyant than lighter ones. In mercury, the heaviest liquid, solid iron, or even lead, will float readily.

HOW BOYS CAN EARN MONEY.

RAY L. SOUTHWORTH.

To help increase the income of the workers who read **AMATEUR WORK** by means of some little business that will be agreeable and dignified, the following are offered. All have been actually employed, and therefore are possible for these conditions. Although there are two conditions named and the suggestions are placed where it seems the most practical, yet it may

be found very useful in some instances to use several in the same locality.

There are some important requisites that a boy must possess if he will be successful. It has been found that where there was hustle with carefulness, honesty and integrity, a reputation was soon made that guaranteed success in the following, and in later life as well.

An individual will discover that there are some things he can do very easily and excel others, and when there is aptness in this way for one thing, it were well to specialize in it.

Business without capital.

a. There is the possibility of acting as errand boy before and after school for ladies of the neighborhood, offices and markets.

b. Parcel delivery by foot, bicycle, or wagon should a horse be at one's disposal.

c. Acting as usher at various public gatherings.

d. If in a large manufacturing centre, buy tools and supplies for workers living outside; that is, a mail order business, charging a small commission.

e. Have pieces, like small motor castings, engines, etc., cast by the thousand, then advertise and sell.

f. Taking some quantity of ice and spring water from the large companies and delivering to immediate neighborhood, and receive a commission on amount handled for the company.

g. Collect eggs, butter, poultry, etc., from farmers and sell to regular customers every Saturday at the increased price that guaranteed, good, fresh produce brings.

h. Small sign and notice printing and painting, specializing in store window-display signs. Have a set of good samples to show as one goes about to solicit patronage.

i. Take an agency for a laundry; collect and deliver, taking commission.

j. Clerking and helping in stores on Saturdays.

b. Book-keeping for small concerns.

l. Private tutoring to boy friends.

m. Care of furnaces and other chores, having six or more, and take by written contract.

n. One may have a friend who has a tin shop in which ornamental articles, as lamp shades, lanterns, etc., may be made, and then sell these in the large department stores; likewise the same may be done in making and selling fancy boxes of wood.

o. Coasters may be made that can be used for sleighing parties when a horse is attached.

p. It is possible to clean and press clothing with trouser-presser as a specialty. Can use mother's ironing outfit and exchange work with her for its use.

g. Some boys will find themselves quite successful at collecting bills.

Business with a small capital.

a. Build furniture to sell. First there is a possibility of making such pieces as are given in **AMATEUR WORK**, then again, making pieces to order, with the stain and finish to suit the taste of the buyer.

b. Start a news stand. Be sure to have a complete

and attractive display of all good publications.

c. At pleasure resorts there is opportunity for rental of tents, land and cabins.

d. In many instances there is opportunity to do type-setting of various kinds.

e. Establish a tinware and small repairing shop.

f. Raising blooded chickens to sell; also eggs.

g. Procuring subscriptions to papers and periodicals.

h. Selling some good novelty for about ten cents, such that the seller will not be ashamed to meet the buyer on the day following the sale.

i. Build and rent a boat, or row for fishing parties.

j. Buy mechanical and other periodicals and sublet for five days at two or three cents per day per paper to boy friends.

k. Prepare stock to size for pieces in wood, as given in the AMATEUR WORK, then advertise and sell these so buyer can finish and set up with little work.

l. Mix pigments in dry state for stains, so that for a certain stain it will only be necessary for the buyer to add the liquid before using.

m. Some boys have discovered that they can do very satisfactory work in designing and using the sewing machine to make ties, mufflers, fancy vests, etc., and sell to boy friends who are always ready to purchase a neat and attractive piece of wearing apparel.

LANTERN SLIDES FROM PRINTS.

Making lantern slides from book illustrations without a camera is possible by a method described in *Camera Craft* by B. Roloff. A half-tone illustration from a popular magazine may be found to have its back covered with printed matter. Now it is desired to use that illustration as a negative, and the sensitive plate as a positive, resembling the method of a bromide paper. By printing through the illustration as it is, the printed matter on the back would also show; so the first thing, then, is to get rid of this. The illustration is cut out, placed face downwards on a piece of ground glass, and the back is wetted slightly by means of a wad of cotton or a sponge until the dampness shows signs of coming through. It must not be made thoroughly wet, as that might injure the ink on the face. With a piece of medium emery paper gently rub the moistened surface until all the ink is off the back. This will leave a roughened surface which can be improved by using a finer grade of emery paper.

Now dissolve 3 oz. of gelatine in 1 oz. of water, add 1 oz. of albumen, and then a few drops of salicylic acid to act as a preservative. The albumen may be made by beating up the whites of eggs. This thick solution is lightly smeared on to the roughened surface of the paper, care being taken not to leave streaks, and for this reason either a soft wad of cotton or a small camel-hair brush should be used. The result is a new surface on the back of the print, smooth and finished as before. Now the print is ready for making the neg-

ative, though should it not be sufficiently translucent, apply vaseline, Canada balsam, or a mixture of three parts of paraffin wax and 1 part of naphtha, gently heated until dissolved; rub this in until none remains on the surface, and if the wax solution is employed, the paper should then be slightly heated, placed between blotting papers for a few hours, and rubbed again with a clean cloth to take off the surface oil. The illustration may then be placed in a regular printing frame, which is to be taken into a dark-room and a sensitive plate of proper size placed over it, film side down, as in making a print. The exposure may be determined easily. One second a foot or so from a Welsbach burner is usually found to be sufficient for the least transparent illustration. The plate may be developed in the usual way, or a special developer giving great vigor may be used.

TRADE NOTES.

CLEMENT UNIVERSAL SAW BENCH.

The following description of the Clement universal saw bench, manufactured by the American Wood-working Machinery Co., 136 Liberty Street, New York, will be of interest to manual training teachers, pattern makers and others.

This is the heaviest, most convenient and most accurately fitted tool of the kind now made. The box

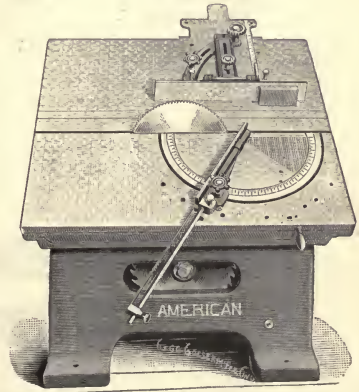

frame is cast in one piece, has three points of support on the floor, and a base surface of 33x30 in; it is thus massive and rigid and cannot be sprung or strained by any ordinary possibility. The arbor yoke is extra long and carries two cast steel arbors 1½ in. diameter with long self-oiling boxes and pulley between. The yoke swings on gudgeons on both sides of the saw line, and the main one is 7 in. diameter and has side bearing shoulders 9½ in diameter with a suitable adjustment for wear; the circular adjustment is by means of

a heavy worm wheel and a double pitch worm with adjustments for wear both longitudinally and laterally; thus there need be no time wasted in changing saws, and no lost motion in the connections.

The table is 45 in. long and 39 in. wide, divided into two sections; the moveable left hand one is 17 in. wide and the right hand one 22 in. wide. The left hand section moves on non-friction rolls and is guided by a planed and scraped way, insuring an accurate cut, and by means of an intermediate frame or spider it can be drawn away from the main section 2½ in. to admit dado heads or special cutters. The entire table, which is unusually heavy and strongly ribbed, can be tilted to 45° or any intermediate point, by means of a screw and radius arm, all bearings of which can be adjusted for wear. An accurately graduated arc and an index are provided on the front of the machine, and a stop at the rear of the frame directly in line of the radius arm holds the table, when down horizontally, square with the saws.

The rippling gauge moves over the entire width of the main table, takes from 0 to 24 in. wide, and the fence tilts to 45° from the vertical. The entire gauge also swings on one of the retaining pins to a horizontal angle with the saw for cutting core boxes, etc. In addition to the position of adjustment by means of the taper pins, there is a micrometer adjustment of 8 in. by means of a steel rack and pinion cut from the solid, making the movement quick and accurate. The gauge may be transferred to the left hand table when required, and there is on its face a detachable block which can be used as a cut-off stop.

The cut-off or mitre gauge is swiveled on the rolling table section, and is accurately stopped by a taper pin at all the principal angles, in addition to which there is a complete half-circle protractor let into the table; to this is added a novel cross graduated sector by which angles corresponding to any required dimension of work can be cut without previously determining the angle, saving much time and calculation; this is a

passes over the saw and thus makes a long, well-supported gauge for large work. When the supplementary cut-off gauge is not in use the fence can be detached from the tongue, and the latter turned over in its slot so as to make a flush surface on the table, as indicated in the engraving.

A special sleeve is provided for the attachment of dado heads up to 2 in. thick; this sleeve takes the place of the nut and loose collar on the saw arbor; heads thicker than 2 in., at the eye will need to be recessed to receive the nut. An idler jack is supplied carrying two 7 in. pulleys running on steel shaft with bronze bushes arranged for self-oiling. This jack is so arranged that the countershaft on the floor at the rear of the machine or below the floor at a distance from the machine. When it is desired to place the countershaft directly under the centre of the arbor yoke the idler jack will not be needed and a fair allowance will be made for it.

The countershaft is turned steel, running in self-oiling, self-adjusting and adjustable boxes. The loose pulley is self-oiling and is 1 in. smaller in diameter than the tight pulley, with a "jump" flange for starting easily. The tight pulley is 10 in. diameter, 6½ in. face, and the speed should be 650 r. p. m. The driving pulley is 28 in. diameter and 5½ in. face, giving the saw arbors about 2,900 r. p. m. The driving pulley is 18 in. diameter and 5½ in. The belt shifter is so arranged that the operator can stop by pressing a pedal lever, but when the counter is placed below the floor a hand lever is supplied. With each machine is furnished a countershaft with a pedal or a lever shifter; two 16 in. saws, cut-off gauge with extension rod, small mitre gauge in main table and connecting yoke for the two, splitting gauge and necessary wrenches.

The accompanying illustration shows the latest creation in an adjustable jawed end nipper manufactured and sold by The Utica Drop Forge and Tool Co., and



valuable addition, and is found on no other tool of this kind. For long work a steel rod is furnished with an adjustable end stop which recedes for cropping off ends and can be used down to 2 in. in length and up to 5 ft. 3 in. The right hand table has a rule graduated to inches and eighths for cutting off. A supplementary cut-off gauge is fitted to the right hand table, consisting of a long tongue moving freely in a slot, to which is attached a swiveling head or fence graduated to 45° both ways and arranged to be connected when desired with the main cut-off gauge by a yoke or arch which

Smith & Hemenway Co., 296 Broadway, New York City. These are made in sizes 8, 10 and 12 inch. The frames are made of a high grade of cast steel and the jaws of the finest tool steel. Prices and illustrations will be furnished to the trade on application.

To make the Amateur lathe more widely known, we will send one of the No. 1 size, 24 inch bed, to anyone sending \$7.50. Mention in order whether round or flat belt is wanted. This is an exceptional opportunity for anyone desiring a small lathe.

AMATEUR WORK

A MONTHLY MAGAZINE OF THE USEFUL ARTS AND SCIENCES

Vol. III. No. 12.

BOSTON, OCTOBER, 1904.

One Dollar a Year.

A RHEOSTAT.

R. G. GRISWOLD.

In order that the strength of a current may be varied at will within certain limits, it is necessary to insert in series with the source of supply a variable resistance. The instrument performing this function is called a rheostat, and, as described herein, has a total resistance of about 47 ohms through 150 steps of .313 ohm each. It has a capacity of 6 amperes and should not be forced to carry more. Fig. 1 shows the instrument complete.

The spool upon which the wire is wound is made of three circular pieces of hardwood, 6 in. in diameter by $\frac{1}{2}$ in. thick; separated by two pieces 5 in. in diameter and $\frac{3}{4}$ of an inch thick. These five pieces are glued together, heated thoroughly in an oven to expel all moisture and given three coats of shellac. Prepare three $\frac{1}{2}$ in. strips of thin asbestos paper equal in length to the circumference of the 6-in. circles, or about $18\frac{1}{2}$ in. Lay off a centre line on two of them $\frac{1}{4}$ in. from the edge and running the entire length, and divide into $\frac{1}{8}$ in. divisions. Wind these strips around the edges of the two outside disks and the unmarked one about the middle disk, cementing them in place with a light coat of shellac. The divisions of one strip should come exactly between those on the other, as shown by the dimensions in Fig. 2. Give the strips a coat of shellac.

The pins upon which the resistance coil is wound are $\frac{3}{8}$ -in. wire brads, driven in the two outside disks at the eighth-in. divisions, allowing them to protrude about $\frac{1}{8}$ in. The coil is made of about 60 feet of No. 24 B. & S. soft-drawn bare German silver resistance wire, wound

from one pin to the next opposite consecutive one. To facilitate the work, fasten the spool in a vise and pass the loop made at one end of the wire by soldering (b Fig 2) over one brad. Then, while holding the wire very taut, pass it from one brad to the other. If the turns about the brads do not lie close to them, they may be made to do so by closing them with a pair of very sharp-nose pliers, easily made by grinding the ordinary kind to an edge at the end. When the last turn has been wound on, it is fastened by soldering to a small brass clip secured to the bottom of disk *c*. Should an odd spacing of the brads bring this end to the top, fasten it there, bringing the end down through a hole in the spool to the under side where it can be brought out in a small groove. It cannot be brought from the top to the binding screw on account of the brush arm.

The protruding ends of the brads should be sent back over the wire loops, which will serve to tighten them, and the heads cut off with a pair of cutting pliers. Then carefully file the ends down until they are just above the wire and will not interfere with the arm. Wind two or three layers of shellacked thin paper strips, $\frac{1}{4}$ in. wide, over the wires just beside the brads, and on these strips wind very tightly several turns of No. 26 B. & S. spring brass wire for binding the wire loops in place in case they should become so heated as to expand enough to slip over the brads. Solder this binding wire at several places to keep the turns together and from slipping over on to the coil. Adjust the various wires where they pass the middle strip of asbestos paper until the

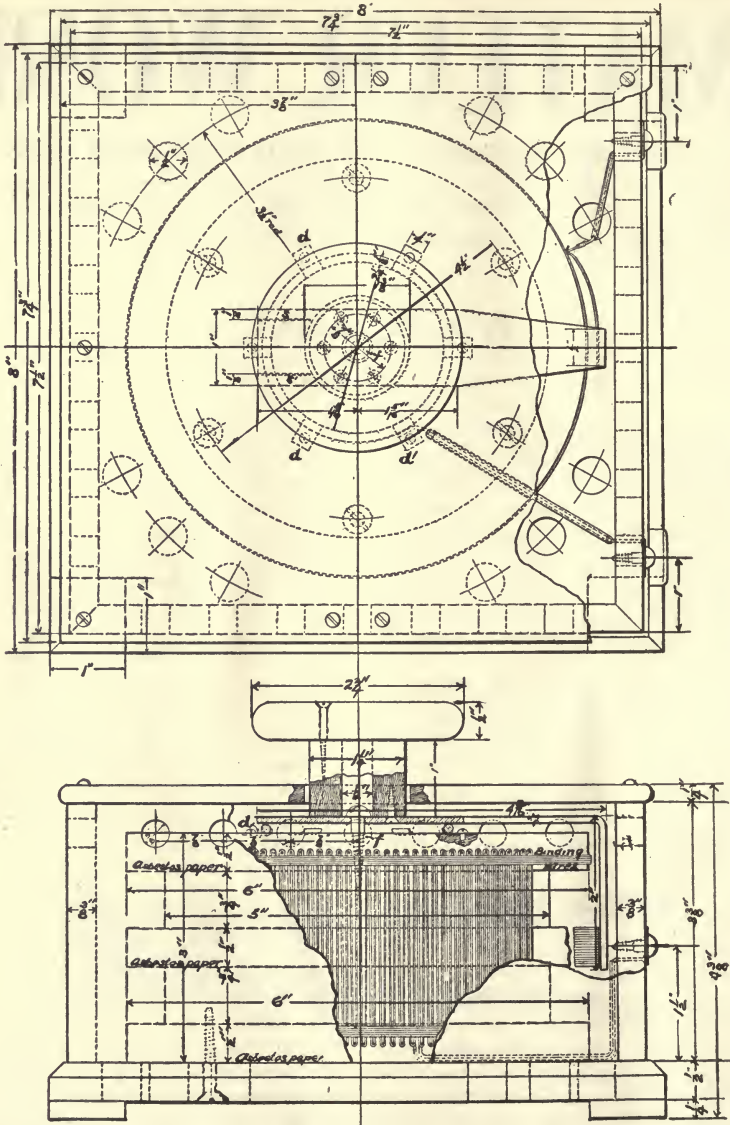

spaces between them are about even, and then give them a thorough coat of shellac, both at the middle strip and on the ends where they turn about the brads, where it should be well soaked in. Place in an oven and bake until perfectly dry, when a second coat should be given and

baked. A piece of felt or hard cloth moistened with a little alcohol will remove the shellac from the surface of the wires where the brush makes contact, while that baked on the middle disk will hold them firmly in place where it passes over them.

The brush arm bears on a ring of $\frac{1}{8}$ in. hard brass wire, fastened to the spool by means of small clips *d*, Fig. 1, soldered to it and set in recesses in the top so that the ring has a solid bearing. One of the connecting wires for the binding posts is soldered to this ring at *d*, and carried down through a hole to a groove in the bottom and thence to the binding screw. The top of this ring should be slightly flattened and polished perfectly smooth.

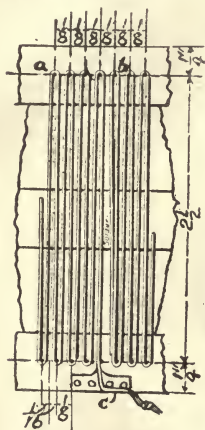

FIG. 2.

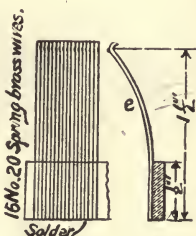

FIG. 3.

The brush arm is made from a piece of $\frac{3}{32}$ in. sheet brass, carrying at its outer end a contact brush made of sixteen pieces of No. 32 spring brass or hard-drawn copper wire, about $1\frac{1}{2}$ in. long and bent as at *e*, Fig. 3, and soldered to the arm. Arrange these pieces so that they all lie in the correct position between two pieces of thick pasteboard, when they may be grasped with the pliers and held in position while being soldered to the arm. Bend the wires as shown so that they bear firmly on the coil wires, but not hard enough to displace them when moving. The bearing surface should be polished very smooth so that the brush will slide easily.

The construction of the hand wheel and stem is plainly shown in Fig. 1. The box should be made of well seasoned hardwood and provided with the ventilating holes shown. The feet on the bottom permit of plenty of room for air to reach the bottom holes, and as the passage of the

current heats the coil a circulation of air is established. After centering the spool on the bottom secure it in place with six screws, so adjusting the spool that the grain of the bottom disk and that of the bottom of the box cross at right angles to prevent warping. The top is made in two pieces so that the interior is accessible without removing the hand wheel. Bend the two sections of the brush arm *s* and *s'* slightly, to form a spring bearing on the wire ring, which will insure a firm contact and prevent binding at any part of rotation. Adjust the pressure of the arm on the ring by means of the screw *f* until it turns smoothly, connect the coil to one binding post and the bearing ring to the other, and the coil is ready for service. The box may be finished in any desirable manner.

This rheostat is not designed to carry a heavy current for any length of time, but simply to afford a means of quickly varying a resistance for experimental purposes, such as in the calibration of galvanometers where the adjustments of resistance are required in small steps.

U. S. Consul-general Patterson, Calcutta, India, reports: Lac is produced in almost every province in India, but principally in the Central Provinces, Bengal and Assam, from which the largest amounts exported are obtained. That produced in other districts is chiefly consumed in local manufactures of bracelets, rings, beads, and other trinkets worn as ornament by the women of the poorer classes, and in the manufacture of wood lacquer work, which seems to have been begun in very remote times. Some very artistic work is now done in this line.

Lac is the incrustation deposited by the lac insects on the branches of certain trees, and is collected, as a rule, by the jungle tribes, who break off the branches on which it is deposited. In this state it is called stick lac, and is sold by the gatherers to local dealers, who sell it to the manufacturers of shellac or button lac, who put it through various processes until it becomes the lac of commerce. During the past two years the product has been comparatively small, while the demand has largely increased. This increased demand is mainly due to the use of shellac in electrical works and, in a minor degree, for making gramophone records. High prices may lead to the adulteration of shellac with resin, which has frequently been done but can be detected by the smell.

Renew your subscription promptly. You will not then forget it and miss a number or two.

A HAND MILLING MACHINE.

ALBERT GRAHAM.

Many, many times have models of inventions and machinery fallen woefully short of the acme of perfection indicated by the general finish of every other part, in those insignificant little keyways and splines which are so deficient when put in with a cold chisel or file.

It is not often possible, from a monetary standpoint, for an amateur to possess a milling machine, and even those that are fitted to be attached to a small lathe often cost from \$60 to \$75, which is nearly as much as that of the lathe.

best be but slow, but it will do the work intended far more rapidly than can be done by hand methods.

The base *a*, Figs. 1 and 2, is made of well seasoned maple glued together on edge. While the glue is setting, be sure that the strips are tightly clamped together. Several pins should be driven through from side to side to prevent the pieces slipping past each other when the pressure of the clamp is applied. This can be readily accomplished by boring $\frac{1}{4}$ in. holes through

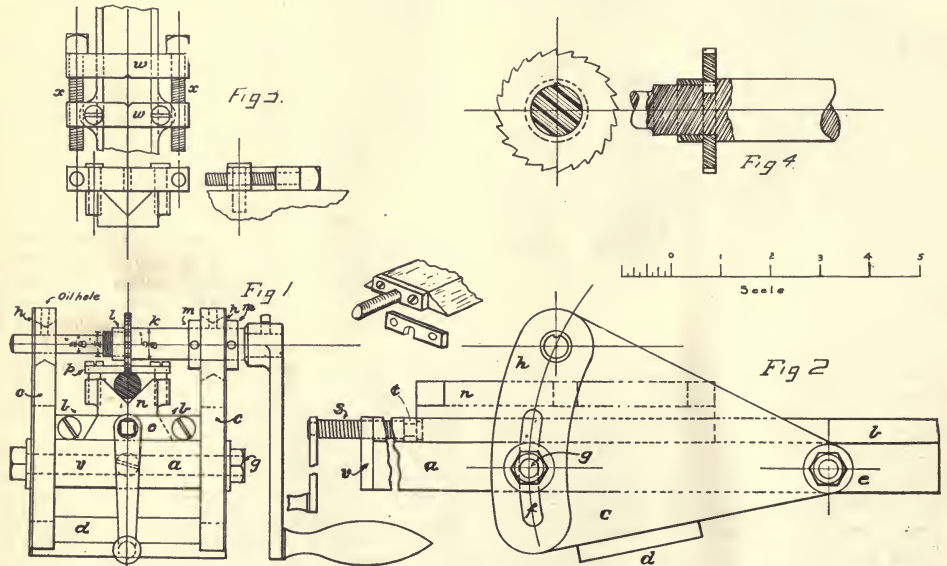

But it is possible for the amateur to construct a small machine out of ordinary materials that will do the work very well indeed. Of course gears cannot be cut on it, but small keyways, grooves in flat pieces and heads of screws, and squares on the end of circular rods or screws may be readily cut. It is to be understood that this is not intended to do the heavy work that a regular milling machine will do, for the power which can be applied is small and the feed can at

each piece, using the first one as a guide, and threading the strips on $\frac{1}{4}$ in. dowels. When thoroughly dry remove the clamps and plane the pieces to a true surface on each side, and making the whole at least 1 in. thick by three wide. This method of construction has the advantage of preventing warping.

The guides *b* are made of the same material, planed perfectly straight and secured to the base, *a*, by several screws placed about two inches

apart. If preferred, one strip may be glued fast and the other left free for adjustment in case of under wear. The angle between the base and the inside of the guide strip is 60°. If this work has been well done, a firm, solid base will be the result, which will last a long time, as maple is a very hard wood of close grain, and after being well seasoned does not warp out of shape. It also has great strength.

The housings *c* are made of two $\frac{1}{4}$ in. pieces of maple glued together by the strip *d* and pivoted to the base by the through bolt, *e*. The circular slot *f* permits the cutter to be raised or lowered at will, while another through bolt *g* serves to clamp it fast. The cutter arbor runs in bearings at the upper end, as shown. Each housing is armored with a brass plate *h* which is secured thereto by small screws. The plate takes the crushing force of the through bolt *g* and prevents the washer under the nut from marring the wood. It also adds greater strength and stiffness to the housings, and the arbor passing through the holes in the brass plates that just fit, enables the strain to be transmitted in a direct line to the clamping bolt *g*.

The arbor *k* is turned from a piece of $\frac{3}{4}$ in. machine steel. An enlarged section in Fig. 4 shows the bearings afforded for the cutter. The cutter is clamped against the shoulder by means of a nut *l*, which is provided with a fine thread, say about 30 to the inch. The cutter being driven by a small key, this nut has merely to hold it against a shoulder and can, therefore, be made very light. By this construction the arbor is kept very stiff, upon which fact depends the smoothness of the cut. Two collars, *m m*, are fitted to the arbor and are adjustable, being fixed in position by the set screws shown. This provides adjustment in the direction of the arbor axis. The crank should be at least six inches long, and if the amateur so desires a fly-wheel may be added to insure steady motion.

The bearings for this arbor are made of Babbitt metal, which is very hard, and can be melted and run around the arbor when the latter is set in place, exactly parallel with the base. The bearings will then be in line and need no further work excepting the drilling of an oil hole from the top. The hole for the Babbitt metal should be countersunk from either side, and if the brass

plate is tinned on the inside the bearing will be soldered to it and make a very stiff construction. When it is necessary to remove the cutter, either to sharpen it or replace it with another, the collar *m* is loosened and the arbor drawn through the bearings sufficiently to allow space between the smaller and adjoining housing, through which the cutter is removed.

The V block *n* should be made of some metal on account of the strain put upon it by the clamps in holding a piece. It may be made of either cast iron or brass, the latter being better on account of its greater toughness and ductility. The piece is small and does not permit large bosses for the clamping screws. The V may be finished with a file to a very true surface, which can be determined by laying a small mandrel in it after the surface of the mandrel has been covered with a thin layer of red lead. The high spots will be covered with the red lead, while the lower portions will not touch it at all. By repeated dressings and trials a very fair V may be made. The bottom of the V block should be filed perfectly true with the upper surface of the mandrel when it is lying in the groove. This will insure the cut being of uniform depth. Fasten this V to the wooden slide *o* by several screws passing through from the under side. A few small clamps should be made of steel to hold the pieces which are being cut, as shown at *p*.

This V, which is really the table of the machine, is fed along the guides by means of the screw *s*, which bears against a collar secured to the end of the block *o*. This screw has a groove cut in its end, as shown at *t*, which allows a horse-shoe shaped slot to pass over it and thus permits the table to be fed in either direction. This arrangement is more fully shown in the small sketch directly above. This feed screw works through a threaded hole in the iron or brass plate V fastened to the end of the base *a*. A three or four inch handle should be fitted over a square on the end to provide sufficient leverage for feeding, as when the cutter is taking even a rather small chip the pressure against this screw is very great. The threads should be very much finer in pitch than ordinarily used on a $\frac{3}{8}$ in. screw. About thirty to the inch will give a fairly fine feed and will not require too long a time to return the table after the cut is made. The handle is made a free fit on

a squared end to enable its removal in case a very long rod is being splined, in which event, the overhanging end would prevent the handle making an entire revolution. This screw may be operated by the left hand, while the right turns the cutter.

To extend the value of this machine a small vise is provided, as shown at Fig. 3, which fastens to the V by the screws similar to the one used for the clamps. The pieces *ww* are made of $\frac{1}{2}$ in. square steel, either machinery or tool, the latter being preferable on account of its ability to be hardened, and these jaws should be hardened if possible. The screws *xx* are simply $\frac{1}{8}$ in. square-headed cap screws. A small V is filed in the centre of each jaw to enable it to hold small screws and cylindrical pieces while the cutter is working on their heads or ends. By providing another boss on the side of the table V, the vise may be swung around until the jaws are parallel with the direction of feed, which is often of great advantage.

The making of cutters is not a very difficult operation. The blanks are turned to size in the lathe, the teeth filed in the periphery by hand and then hardened and tempered. Do not let the fact that the spacing may not be regular worry you in the least, for it is better that they should have irregular teeth; a cutter with regular teeth

will chatter if it is given the slightest excuse, whereas an irregular spacing will tend to obviate this tendency, owing to the inability of the succeeding teeth to drop into the furrow made by the advancing or cutting tooth. This action is exactly similar to that which always occurs in a file of regular cut. Files are now generally made with an irregular spacing which, although not readily determined by the eye, prevents that annoying chatter with its consequent rippled surface.

These drawings have not been dimensioned, but a scale has been laid down from which the measurements may be taken off. This allows the amateur to alter the machine to suit his particular needs if it should not serve as designed. The cutter and section of the arbor is just double the scale to which the machine is drawn.

Do not attempt to use cutters of much larger diameter than $1\frac{1}{2}$ in., as you will not have power to drive them with your arm. Neither will the machine stand up under a cutter much over $\frac{1}{4}$ in. in width, but it has been designed to do the ordinary run of work generally pursued by the amateur, the object in view being to give him something that will do the work and that can be built at a very low cost without the use of more than one casting, which is extremely simple to make and requires no core work.

TELEPHONE CIRCUITS AND WIRING.

ARTHUR H. BELL.

V. Telephone Troubles.

Assuming that several readers have constructed private lines, as described in the September number, a few points of instruction are here given in the clearing of trouble, which is bound to come sooner or later unless the greatest care is taken in periodic inspections of line and instruments. The handling of telephone troubles is facilitated by a thorough understanding of the equipment in use. In a general way, however, it is likely that certain defects and faults will predominate, and herewith is given a few of the most common of these difficulties, with suggestions as to their origin and quickest methods of locating.

Cannot ring or receive a ring. Line or generator circuits open.

Can hear but cannot be heard. In such cases the trouble is usually with the battery or transmitter circuit. A careful examination of all connections therewith should be made.

Weak ringing of bells. Loose connections, bad joints in line or imperfect connections at terminals of line. Bell armature adjustment may be defective.

Hearing bad. Weak battery at the receiving end or imperfect connections. Transmitter at sending end may be defective. Faulty receiver

Noises. Loose connections in line or battery circuit. Too much battery. Bent diaphragm on receiver or particles of foreign substance on the magnets.

Rings O K but cannot hear at either station. Imperfect receiver cord or broken wire in the instrument circuit.

Bell rings without cause. Swinging cross with foreign wires or jarring of instrument.

In the early days of telephony it was considered that any kind of construction was good enough for telephone work, and as a consequence telephone installations were constantly out of order. Today the reverse is the case, the very best construction is none too good, and every possible requirement in construction and equipment is carried out to the smallest details. A very little consideration of the case is required to see how necessary this is. The telephone is one of the most sensitive electrical instruments known, and as it is so sensitive, the introduction of all foreign currents on the line, either by induction or leakage must be guarded against. The telephone current as transmitted is a feeble current, and therefore leakage or undue resistance must be avoided.

Great care should be taken to see that all contacts are bright, firm and clean. The automatic hook connections should make perfect contact and the hook spring should be powerful enough to bring the hook up to the proper position each time.

It is always safe to examine all connections when looking for trouble, especially those where wires are likely to become bent or twisted. The use of dry batteries is warranted by their cheapness, ease of handling and the general satisfaction they are giving in this branch of electrical work. There are a number of good makes which will give good satisfaction for six months to a year, according to use, and at the end of that time should be replaced with a new cell. Wet batteries of the salammoniac type are as efficient as dry cells, but should be kept where breakage or freezing can do no harm, and the cells should be frequently inspected to avoid drying up and crystallizations of zinc.

It will be found by experience that the best types of commercial receivers and transmitters seldom get out of order when carefully handled. The most prolific trouble is loose connections.

PATTERN MAKING FOR AMATEURS.

F. W. PUTNAM.

VIII. Base Piece of Small Jack Screw. — Handy Appliances.

The next pattern to be described is for the base piece of a small jack screw, the design of which was made by J. M. Tate of the University of Minnesota.

Fig. 47 shows a sectional view of the casting, and Fig. 48 the required pattern. It will be noticed that the top core print, *B*, is tapered, indicating that the pattern is solid and not a split pattern. Fig. 48 indicates this, the centre line being added simply to show the parting line if a split pattern is used.

If a solid pattern is made, only the core print, *B*, will be molded in the cope, all the rest of the pattern being in the nowel, the core setting vertically in the mold. A piece of stock $5\frac{1}{2}$ in. square and $5\frac{1}{2}$ in. long is necessary for constructing this pattern if the grain of the wood is to run parallel

to the long axis. As a piece of stock of this size will be hard to obtain, the pattern may be made in the following manner. Prepare two pieces $5\frac{1}{4}$ in. square and $2\frac{1}{8}$ in. thick, planed on both sides until true parallel surfaces are obtained. Glue these two pieces together and clamp carefully in a vise until the glue has become thoroughly hard. Mark a circle $5\frac{1}{4}$ in. diameter on one of the faces of this block and cut to as near this circle as possible with saw and chisel.

Place the block on the screw centre and turn to the required shape and size, using templets to aid in obtaining the desired curves. The core prints are shown in Fig. 49 and are to be turned and fastened to the pattern as in previous exercises.

The core box for the pattern is shown in Fig.

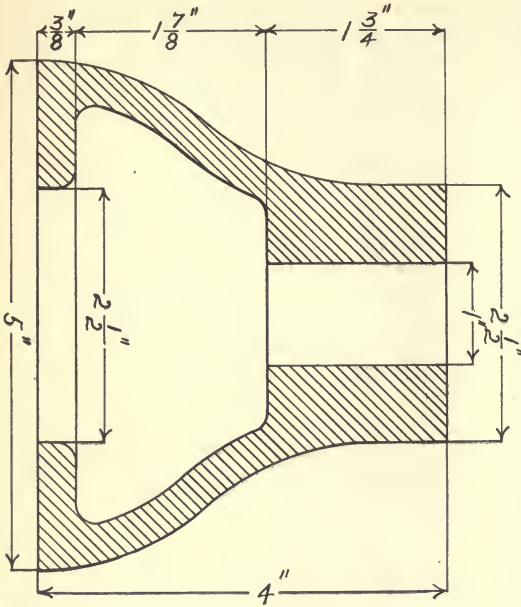

FIG. 47. CASTING FOR BASE OF SMALL JACK.

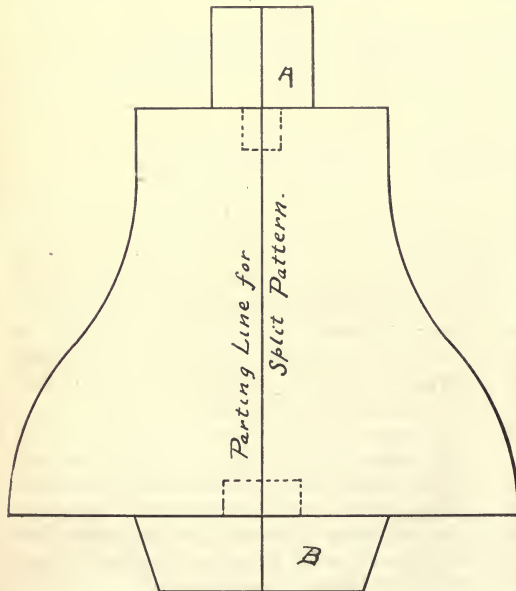

FIG. 48. PATTERN FOR BASE OF SMALL JACK.

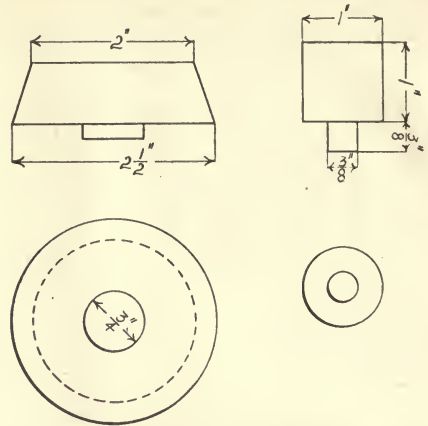

FIG. 49. CORE PRINTS FOR SMALL JACK.

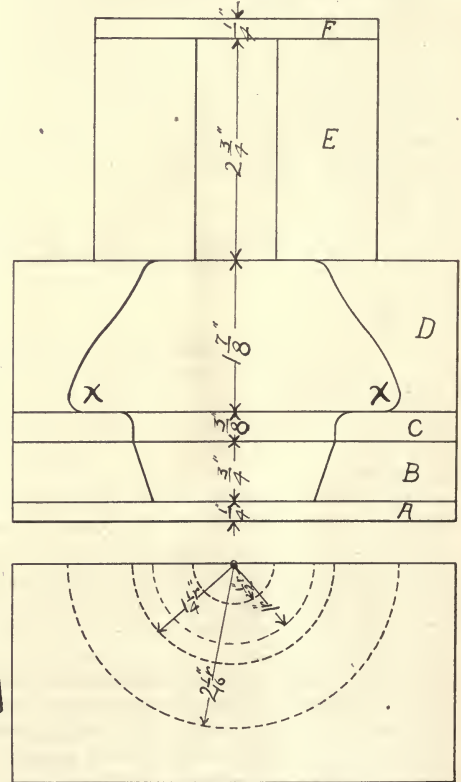

FIG. 50. CORE BOX FOR SMALL JACK.

50, a half core being used. It will be advisable to make this core box of six-pieces of stock, as indicated in the figure. *A* and *F* are simply end pieces of stock. *E* is to be laid out with compasses, square and gauge and pared out with the gouge. *D* should be attached to the face plate and turned out with a round-nose chisel, using a templet to test the curves. Use a block 5½ in. square and 2 in. thick for this work, and make sure that the screws which fasten it to the face plate do not interfere with the turning.



FIG. 52. PATTERN MAKER'S CAN.

bottom of the mold. If it is found on trial that this does happen, a split pattern should be made, in which case the core print, *B*, Fig. 48 will be straight instead of tapering.

In this and in many of the following articles on pattern making will be shown cuts of various tools, appliances, etc., used by pattern makers and in the foundry. These cuts have been very kindly loaned me by the S. Obermayer Company of Cincinnati, Ohio.

Fig. 51 shows a Pinch Dog, referred to in my September article as being used for fastening two pieces of wood together for turning in a lathe.

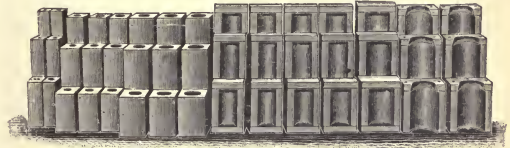

FIG. 54. SET OF CORE BOXES.

Fig. 52 shows the Economic Seamless Steel Can for shellac, paint, varnish, etc. The hermetical seal preserves brushes and contents. This can is made from smooth surface, cold rolled "Swedish" steel, drawn seamless, in two parts. It commends itself at once to pattern and cabinet makers and all who use fine paints, varnish and shellac.

Fig. 53 shows labor saving leather pattern fillets. This style of fillet is a great time and labor

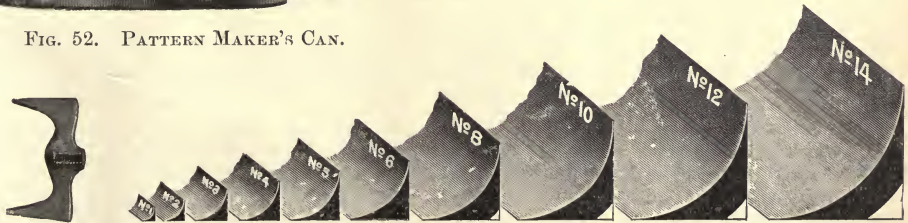

FIG. 51. PINCH DOG.

FIG. 53. LEATHER PATTERN FILLETS.

When the block is finished, remove it from the face plate and cut it in halves, with the grain, using the smoother half for the core box.

There is one objection to the making of this pattern solid and using a vertical core, and that is the danger of the core breaking or crumbling away at *X*, Fig. 50 and dropping down into the

saver as the applying of it is accomplished with a single operation. It is not affected by heat, cold or moisture, any more than is the pattern.

Fig. 54 shows a set of standard core boxes consisting of fourteen sizes and three lengths to each size. They are made of hard poplar and are in very common use.

HANDY HINTS FOR AMATEURS.

Contributions are solicited for this department, and for each accepted article the sender will be given the choice of any one-subscription premium from our premium offers.

BICYCLE FOOT POWER.

W. C. HOUGHTON.

Most boys have, or can obtain at a very small expense, a bicycle that has passed its usefulness as such. If the frame, crank shaft, chain and rear wheel are in fair condition, it can be converted into a first-class foot-power for an emery wheel, a dynamo or any high speed machinery.

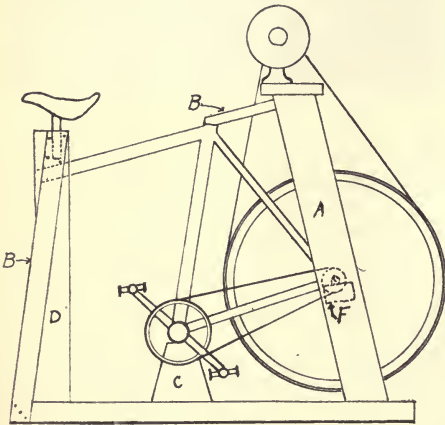

First remove the front fork, wheel, etc., and cut off the top bar of the diamond close to the steering head. Cut away the lower bar close to the crank-hanger. Remove the rear tire and fasten some strips of lead all around the groove in the wood rim. These can be cut from old lead pipe. Take care to distribute the weight evenly all around. Next plane out a long, thin strip of wood as wide as the rim and a little thicker in the middle than at the edges. Bend this around the rim and secure with small nails or screws. This is for the belt, which does not run properly in the groove.

Next build a frame, as per the drawing. No dimensions are given, as the size and proportion of the parts will vary according to the dimensions of the bicycle used. The drawing is, how-

ever, made to a scale of 1 in. = 1 ft. The base board should be about 4 ft. long and 2 in. thick and about 15 or 16 in. wide. The supports, *A*, should be 2 in. x 4 in and put far enough apart to let the rear axle between them. The axle is to be fastened to blocks *F*. The supporting block, *C*, and saddle post, *D*, are sufficiently explained by the drawing. The saddle post should be rigidly braced from the base by braces, *B*. Braces should also be put at *G*, between the top of the diamond and the main supports, *A*. The saddle should be rigidly fastened in the post. This may be done by drilling a hole through the wood and the steel tube and driving in a large wire nail. The crank hanger may be fastened to the block, *C*, with thin steel straps put over it and screwed to the wood.

Such a foot power as this will easily drive an emery wheel 2000 or 2500 r. p. m. with moderate pedaling.

NAIL AND SCREW CABINET.

F. E. LINDSAY.

The cabinet herein illustrated is designed to do away with the needless boxes of nails and screws which too often litter up the shelves and work-bench of a small shop. Room is valuable, and it also requires time to hunt through such a mass.

This cabinet has three drawers, the upper one for brads and nails, the middle one for wood screws. It is designed to go either above or below the work bench in such a convenient position that it may be readily opened with one hand. If above the bench the case should be placed at such a height that the lower drawer can pass over tools lying on the bench without striking them.

The drawers are made rather shallow, so that the smaller divisions may be readily reached. The boxes in the front row are each capable of holding a full pound of wire brads, while the middle row is provided with smaller boxes for odd sizes and tacks. The back row holds large nails, which are less used than the smaller sizes.

The middle drawer has much smaller divisions on account of the smaller number of screws generally in stock. The front row may be used for flat head iron and brass; the two adjoining boxes holding the same size screws and the middle row containing the same sizes in round head screws. The back row may be used for very large screws.

The under or bottom drawer is to contain machine screws of various sizes disposed to best advantage. The front row may contain iron screws in flat and round heads, and the middle row the corresponding size in brass. The boxes in the rear can hold the large sizes, nuts and washers.

In fitting the divisions glue them as well as nail, and see that they fit close to the bottom so that the smaller pieces cannot slip underneath. Give the drawers two or three coats of shellac. The sides should be provided with $\frac{1}{2}$ in. grooves $\frac{1}{4}$ in. deep, which slide on a rail of corresponding size fastened to the side of the case. This form of slide is easily made and works very smoothly.

Anyone who has not possessed such a cabinet can hardly realize its great advantage. It is well worth the time spent on it, as will be granted by anyone making one.

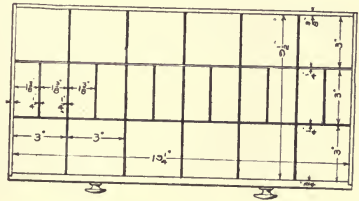
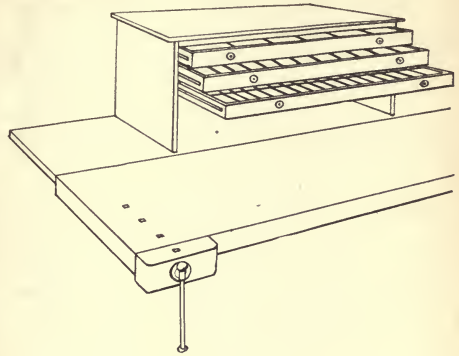

NAIL AND SCREW CABINET.

NOTES ON WIRELESS TELEGRAPHY.

L. T. KNIGHT.

I. Nature of Wireless Telegraphy.

Wireless telegraphy is the name given to the transmission of dots and dashes by means of waves set in the ether by powerful oscillating discharges.

Ethral waves conveying perceptible light and heat have long been recognized, and these waves are known to have a velocity of propagation of about 180,000 miles per second, differing from one another only in their wave length and frequency. Violet light waves have a frequency of 750 trillions, and the lowest perceptible heat wave is estimated at 160 trillions per second.

With the discovery that an electric spark or discharge could produce disturbances at a distance without a conducting medium, came the general acceptance of what has been styled the Hertzian wave, a new and distinctive wave, pos-

sessing practically the same velocity as other ethral waves and likewise capable of reflection, deflection and refraction.

Early experiments consisted merely of devising apparatus for sending Hertzian waves into space and receiving the same at a distance. More recent experiments have been devoted to the adjustment of wave lengths, with the intention of perfecting methods whereby messages can be sent to predetermined points speedily and without fear of interference.

Since the velocity of all ethral waves is about the same it will be found that the length varies inversely with the frequency. In a recently published article on ethral waves, by a foreign scientist, was given such an admirable description of the relation of the aerial wire and the

wave length, that the writer prefers to quote a paragraph or two, instead of setting forth the same matter in a less masterly way.

"If a rod of steel be held firmly by one end and struck a sharp blow, it will vibrate at a *frequency* depending entirely on the *length* and other *physical* properties of the rod. The *period* of this vibration will be the same in all parts of the rod:—the *amplitude* will vary from nothing at the held end to a maximum at the free end. Similarly, if a wire or other conductor having one end insulated and thus free to vibrate electrically, while the other end is held at a constant potential by earthing or other means, be struck an *electric* blow, electric oscillations will be set up in the wire, the *frequency* of which will depend entirely on the length and other properties of the wire, and the *amplitude* of this vibration (alternating potential) will vary from nothing at the earth end to a maximum at the free end.

If the steel rod had been struck a number of light blows properly timed, the same *amplitude* of vibration could have been obtained as by the

single heavy blow, but these light blows must be properly timed. From the oscillatory nature of the electric spark it is not practicable to strike one heavy blow and so get the vibratory or radiating effect. The frequency of the blows delivered by it must be suited to the natural frequency of the wire. This accord of spark frequency with aerial wire is known as *resonance*. When perfect resonance is obtained the aerial wire vibrates freely and sets up an electrical wave in the ether which can be shown to be proportional to the length of the wire."

But in a simple installation, where one terminal of the spark gap is connected to one end of the aerial wire and the other terminal of the spark gap connected with the earth, the capacity of the aerial wire being small and likewise the quantity of oscillating electricity small, the oscillations are short lived and not likely to be effective at any distance.

The value, therefore, of a closed circuit installation presents itself, and this subject will be fully treated, together with diagrams, in future articles.

CHEMICAL FIRE EXTINGUISHER.

WILLIAM K. SLYKE.

If there is any place where fire is likely to occur it is in the amateur's workshop, especially when he is experimenting with combustible chemicals, and if it should start from oil, naphtha, benzine, tar, varnish and similar inflammables, water has little or no effect. The Chemical Fire Extinguisher, however, makes short work of such fires. The stream from it is mainly water impregnated with a chemical gas. This gas is carried with the stream and has an effect on the fire independent of the actual stream itself. To make such an extinguisher is not a hard task, the hardest part being the tank, which should have a capacity of about three gallons, although smaller ones can be made. The one here described is of this size, made from about No. 10 gauge copper plate and must stand at least 150 pounds pressure to the square inch, the stronger the better. The seam of the tank should be riveted and soldered, as should also the top and bottom. Tanks of the

required size can be made up at any plumber's supply shop.

In addition there is also needed a 2½ in. brass coupling and a brass plug to fit the coupling. The coupling should be cut in half with a back saw, as it is too long; the other half can be used for another extinguisher. In the centre of the top of the tank cut a hole large enough to admit the coupling snugly; have about ½ in. of the coupling on the outside so as to solder it in the tank which will make a good strong job.

Next, get a bottle capable of holding four fluid ounces of sulphuric acid. This bottle should be narrow enough so that after it is in the holder it will slip easily into the tank through the opening in the coupling.

From the brass plug a holder must be suspended to hold the bottle. Cut a circle in brass ⅞ in. thick, a trifle larger than the bottom of the bottle. No dimensions can be given, as the bottles will

no doubt differ somewhat in size and shape. Then cut two strips of brass $\frac{1}{2}$ in. wide and $\frac{1}{2}$ in. longer than the length of the bottle. This extra $\frac{1}{2}$ in should be turned at right angles to allow the strips to be soldered to the round piece of brass. At the long end of these strips and about $\frac{1}{4}$ in. from the end, drill a $\frac{1}{8}$ in. hole. Solder these strips to the round piece of brass. Half way from the top of these strips solder another strip of brass $\frac{1}{2}$ in. wide, forming a circle of the same diameter as the bottom circle; this will keep the bottle from falling out. See Fig. 1. Make two more strips of brass $\frac{1}{2}$ in. wide and about $2\frac{1}{2}$ in. long, turn in $\frac{1}{2}$ in. to allow a good soldering surface, as these ends are soldered to the under side of the plug. In the long ends of these two strips bore $\frac{1}{8}$ in. holes. A copper rivet is now passed through the hole in each of these strips, as shown in Fig. These should not be riveted too hard, as they are to act as a hinge, allowing the plug to be turned back so that the bottle can be inserted easily. Next, make a lead stopper for the bottle; this should fit very loosely, so that if the bottle were tipped neck down the stopper would easily fall out.

On the side of the tank 1 in. from the top, drill a hole and insert a short piece of $\frac{1}{4}$ in. brass tubing bent to form an elbow and soldered in place as in Fig. 1. Slip on a piece of 1 in. rubber hose about the length of the tank. This hose should be of good quality and strong enough to withstand the required pressure of about 80 or 90 pounds. An excellent way is to wind electric tape around the outside. To the free end of the hose attach a small nozzle with an $\frac{1}{8}$ in. outlet. This hose should be fastened very securely to the tank and nozzle with several turns of copper or brass wire. The extinguisher is charged as follows: Fill the tank with water within four inches of the top, into the water dissolve $1\frac{1}{2}$ lbs. of bi-carbonate of soda, which can be procured at at any drug store. Fill the bottle with 4 fluid ounces of sulphuric acid, leave the neck of the bottle empty, insert the lead stopper and place the bottle in the holder; then insert the bottle and holder in the coupling in the top of tank and screw down tight. A leather washer should be placed on the plug. The plugs should be of the shape shown in the drawing. To the sides of the tank should be soldered a handle for carrying and hanging up. There

should also be a handle on the bottom of the tank

To operate the extinguisher it is only necessary to carry to the fire and turn it upside down, using the bottom handle to hold it and direct the stream, which will be very powerful. It will be seen that when the tank is turned upside down the plug will fall out of the bottle, thereby allowing the

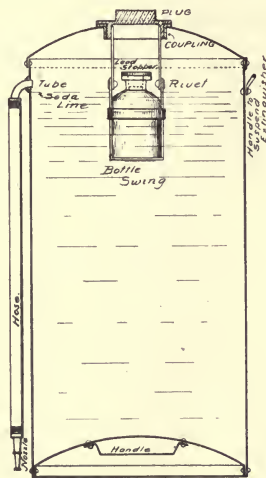

acid to flow into the soda solution. As soon as the two liquids meet carbonic acid gas is generated in quantity, forcing the water out of the nozzle with great force; the water is also impregnated with this gas, which acts as a blanket to the flame. When inserting the bottle in the tank see that the neck of the bottle will be above the soda line. The bottle holder should, if convenient, be tin plated on the inside. The extinguisher should be charged and discharged at least once a year cleaning all the parts before recharging. The extinguisher should hang in a central location easy of access at all times.

The London Daily Mail has the following. Medical men and nurses abounded at the recent opening of the Medical Exhibition. One stall contained nothing but samples of a new anæsthetic which bears the restful name of "somnoform", a liquid the boiling point of which is 23° below zero. The moment it comes in contact with air it becomes a gas. Its great virtue, from a medical point of view, is that breathing stops before the heart when it is administered.

AMATEUR WORK.

DRAPER PUBLISHING CO., Publishers,

88 Broad St., Room 522, Boston, Mass.

A Monthly Magazine of the Useful Arts and Sciences. Published on the first of each month for the benefit and instruction of the amateur worker.

Subscription rates for the United States, Canada, Mexico, Cuba, Porto Rico, \$1.00 per year.

Single copies of back numbers, 10 cents each.

TO ADVERTISERS.

New advertisements, or changes, intended for a particular issue, must be received at this office on or before the 10th of the previous month.

Entered at the Post Office, Boston, as second class mail matter, Jan. 14, 1902.

OCTOBER, 1904.

Note the new address, 88 Broad St., Room 522.

With this issue we close the third year of publication of this magazine. During this time many incidents have occurred to encourage us and which show that our work is meeting with full appreciation from our readers. The value of the magazine in both a practical and educational way is amply evidenced by the many letters we are constantly receiving, and which serve as a stimulus to further and better efforts in this direction. Our staff of contributors is being constantly enlarged, so that we can in the future present subjects of continued interest and value to the amateur worker.

During the coming year we shall continue to present many topics relating to mechanics, electricity, wood working, boat building, photography, as well as articles having special bearing on these subjects. The making of machines and instruments likely to be of service to the amateur will receive a prominent place. Constructive work for the junior department will also be given due prominence. Altogether we feel that our readers will find much which will be directly helpful and of value. Suggestions are desired and welcomed

and will be utilized so far as it is possible to do so.

One of the latest of our readers to receive the "Amateur Lathe" writes: "It is a very fine machine. I expected a great deal of the lathe, but it far exceeded my expectations." Another one writes: "I don't see how you can offer such a fine lathe at the liberal terms upon which I received mine."

A turning lathe is such a necessary tool to amateur mechanics that those without them should consider the purchase of one at the earliest which their means will permit. For small work the "Amateur Lathe" is just what is wanted.

Volume III., bound in cloth, uniform with the two previous volumes, will be ready about Oct. 20. Price \$1.50, postpaid. The three volumes, bound in cloth, and a subscription for the fourth year, will be given for \$4.50.

Consul Jackson, La Rochelle, France, reports: A part of this consular district, principally in the southern section, has been invaded by immense numbers of "campagnols" or field mice (*Arvicola agrestis*). The presence of this diminutive pest has caused serious concern in the agricultural districts, for the powers of destruction possessed by one of the creatures are tremendous. It not only destroys large quantities of living vegetation in seeking its food, but lays away an ample stock for winter consumption. There is scarcely a living plant within its reach that is not eaten or destroyed by it.

It has been calculated from experiments that each adult field mouse eats from two-thirds of an ounce to 1 ounce of living plants a day, which means a consumption of from 16 to 24 pounds a year. It is estimated that the average number of field mice to be found upon a hectare (2.47 acres) was 1,350. They consumed annually at least 13½ tons. It will be seen, then, that the anxiety among farmers is justified. The method used to destroy these pests which is considered most efficacious is by a microbe which is deadly to rats and mice only, domesticated animals being immune to its influence. This method of destruction has been recently commenced and carried out on a surface of 2,800 acres, and has proved to be able to accomplish the destruction of the mice, while the game, fowl and other animals of the farm were in no instance affected.

DESIGN FOR A LIGHT GASOLENE CAR.

J. C. BROCKSMITH. M. E.

Reprinted by Special Arrangement with the American Electrician.

The crank shaft is shown in Fig. 9. This is preferably made from a solid open-hearth steel forging, the cranks being cut from the solid metal. Figs. 10 and 11 show respectively the top and bottom halves of the crank case. These are intended to be cast in aluminum alloy containing about 25 per cent zinc. The halves should be planed and carefully surfaced where they bolt together; this joint should be perfectly gas tight, and it is preferable not to use packing but to rely on the surfacing and the bolts for drawing the parts in close contact.

Fig. 12 is a detail of the contact maker for use with jump spark ignition. A spark is required in each cylinder once in each revolution, and since the cranks are at 180° the contacts are also arranged 180° apart. The plate upon which the contacts are mounted is bored for and centered upon the main bearing boss. The plate may be made of aluminum or brass and only the stationary contact need be insulated from it. That is to say, the spring blades are grounded on the engine frame, which is a necessary part of the scheme of connections.

Fig. 13 is a diagram of connections of the sparking apparatus. A separate coil is required for each cylinder. For spark coils and plugs the builder will do well to purchase standard articles. Also in regard to the carburettor, it is probable that more satisfactory results will be obtained from a ready-made article than from one of the home-made variety.

Fig. 14 shows the details of the motor fly-wheel and clutch. The wheel is of cast iron and is to be turned all over, the inner surface of the rim to be finished to a 15° taper and forms the female portion of the cone clutch. The male portion of the clutch is a disc of aluminum alloy faced with leather and riveted to a steel centre which is bored to fit the reduced end of the crank shaft. A spiral spring forces this disc into contact with the fly-wheel surface, so that the cones are always in engagement except when the clutch pedal is depressed while changing from one gear combination to another. The spring pressure thus applied is entirely self contained and does not produce any end thrust upon the motor or change gear bearings, due to the fact that the fly-wheel is covered by a cap which takes care of this thrust and at the same time forms a dust proof cover for the parts. In order to disengage the clutch the shaft carrying the male cone must have an endwise motion of about $\frac{1}{4}$ in., which is allowed for in the jaw clutch that connects the motor shaft to the speed change gear.

Fig. 15 shows the speed change gear, with the top half of the case removed to make clear the arrangement of the gears and their operation. The driving shaft is round and has secured to it by means of pins four gears of different diameters. The driven shaft is square and has mounted upon it a spider carrying three gears of suitable diameters to mesh with the gears on the driving shaft. The spider may be slid endwise along its shaft so that any desired pairs of gears may be engaged. The drawing shows the gears engaged for the first forward speed, which gives the highest ratio of engine turns to rear wheel revolutions. The reverse speed gives the same ratio as the first forward speed except that an idler gear is interposed between the driving and driven shaft, thus changing the direction of rotation. The reverse gear is obtained by moving the gears to the left of their position in the drawing, and the two other forward speeds are obtained by moving the spider to the right of its present position. The centre lines at the extreme right of the figure indicate the exact distances through which the shifter rod must be moved to get the various combinations. The universal joint which transmits the motion to the rear axle gear and also in the brake drum are shown in this view. The accompanying table gives the data for gear ratios and sizes of gears for various combinations:

Fig. 16 is a top view of the complete gear and case, showing the length of arms for bolting to the frame work of the car, the shifter rod, brake drum, removable cover and universal joint. Fig. 17 is an end view of the gear case, which helps to make clear the position of the idler gear by means of which the reverse speed is obtained. It also shows the screw plug at the bottom of the case, through which the old oil may be drained off. The case should always be partly filled with a heavy oil and the gears and bearings are then lubricated automatically. The best practice indicates that all gears should be cut from machine steel, have the teeth rounded or beveled on the edges, and then case hardened. If for any reason this is impracticable, phosphor-bronze might be used, though it will not, of course, wear as well. Cast iron is, of course, out of the question, as it is so brittle that the teeth would be likely to strip in changing speeds.

Fig. 18 shows the construction of the rear axle and the bevel gear drive. The revolving portions of the axle are of $\frac{1\frac{1}{2}}$ in. solid steel turned down to 1 inch at the hubs and keyed in. The differential gear is of

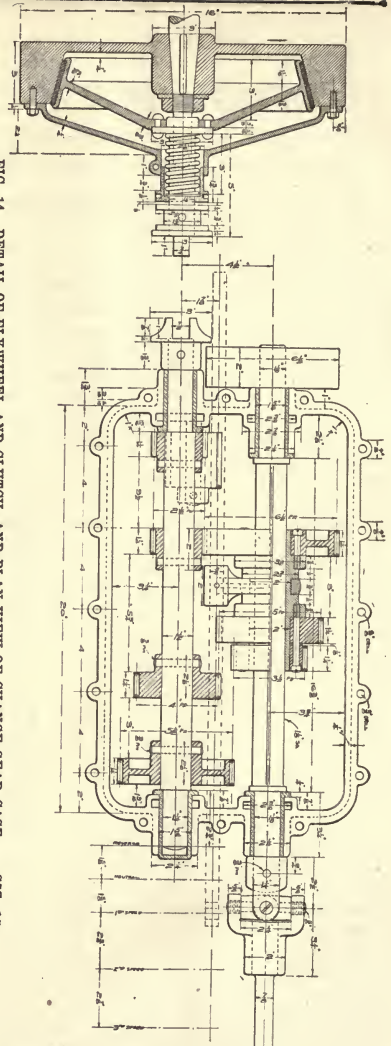

FIG. 14. DETAIL OF FLYWHEEL AND CLUTCH, AND PLAN VIEW OF CHANGE GEAR CASE..

FIG. 15.

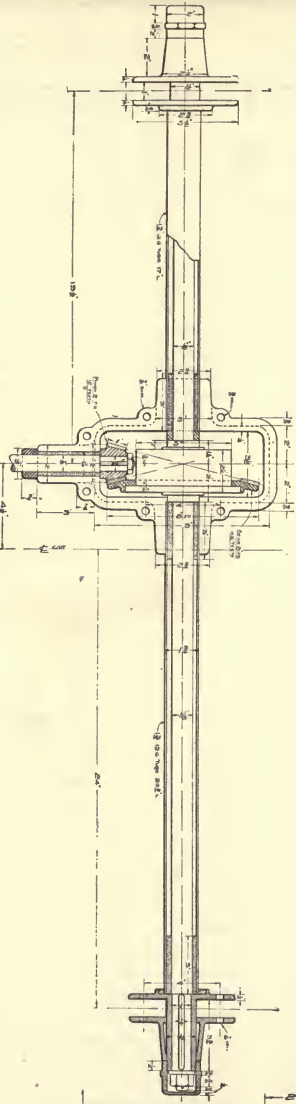

FIG. 18. DETAILS OF REAR AXLE AND BEVEL GEAR.

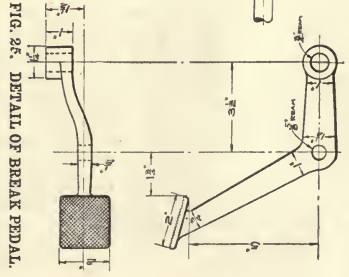

FIG. 25. DETAIL OF BREAK PEDAL.

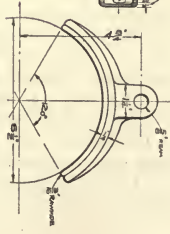

FIG. 26. DETAIL OF BREAK SHOE.



FIG. 20. DETAIL OF FRONT AXLE.

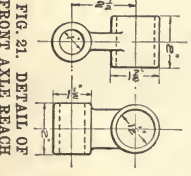

FIG. 21. DETAIL OF FRONT AXLE REACH FITTING.

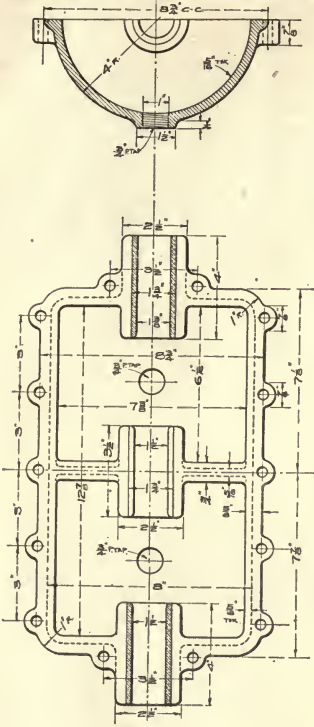

FIG. 11. DETAIL OF LOWER HALF OF CRANK CASE.

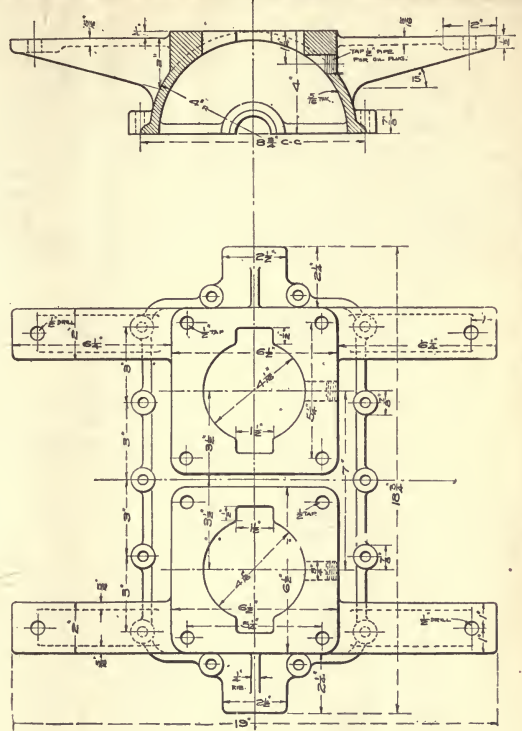

FIG. 10. DETAIL OF UPPER HALF OF CRANK CASE.

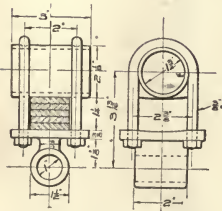

FIG. 19. DETAIL OF REAR AXLE SPRING CLIP AND REACH FITTING.

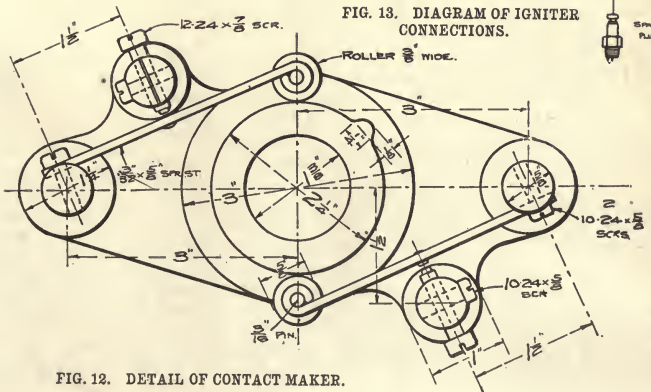

FIG. 12. DETAIL OF CONTACT MAKER.

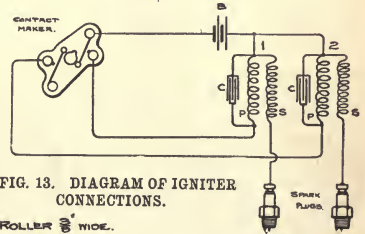

FIG. 13. DIAGRAM OF IGNITER CONNECTIONS.

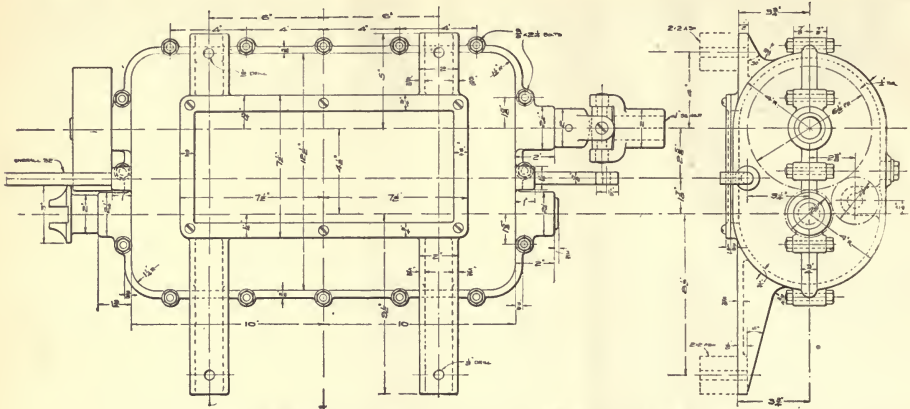
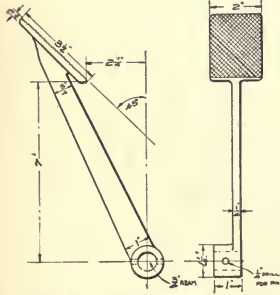

FIG. 16. PLAN AND END VIEWS OF COMPLETE CHANGE GEAR CASE.

FIG. 17.

FIG. 23. DETAIL OF CLUTCH
RELEASE PEDAL.FIG. 24. DETAIL OF CLUTCH
FORKED LEVER.

standard construction and is, therefore, not detailed. The hubs may conveniently be of phosphor-bronze or steel. The gear case is intended to be cast of aluminum alloy containing 25 per cent zinc. The same is used for the engine crank case and the change gear case. The revolving portions of the axle are enclosed in a $1\frac{1}{2}$ in. steel tube which is fitted with phosphor bronze bushings at its extremities. It will be noted in this connection that only plain bearings are used all through the construction of the car. Fig. 19 is a detail of the spring clip fitting for the rear axle. This consists of a steel casting which is bored to fit the axle tube and is clamped thereto and to the spring by means of a pair of $\frac{3}{8}$ in. "U" bolts.

Fig. 20 shows the construction of the front axle and hubs. The axle consists of a length of $1\frac{1}{2}$ in. tube brazed into the forked steering ends. The front hubs are the same as the rear ones with the exception, of course, that they are bored a running fit for the axle instead of being keyed on. Further details of the axle ends can be obtained from Fig. 2. Fig. 21 shows the reach fitting for the front axle. This is bored to fit the front axle tube and the reach is intended to be a turning fit for the lower portion so that the running gear may adjust itself to any unevenness of the road. The reaches consist of a pair of steel tubes, the location and length of which may be seen in Fig. 1. They have solid ends brazed in and a nut placed on the outside.

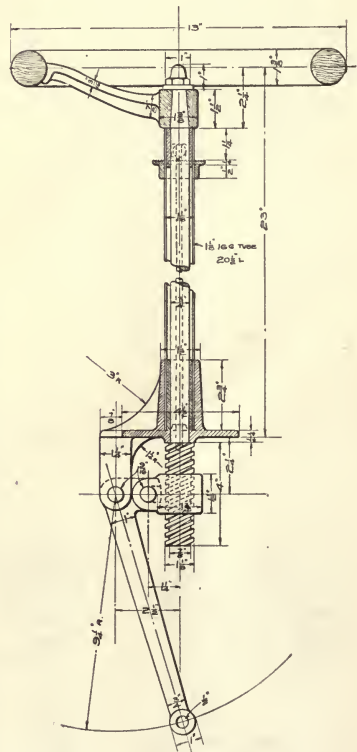

FIG. 22. DETAIL OF STEERING COLUMN.

Fig. 22 shows the construction of the steering column. The tubular portion is stationary and has attached to it near the top the spark and throttle levers; the centre rod turns with the hand wheel and operates the screw at the bottom. The screw is $1\frac{1}{2}$ in. outside diameter and has three threads with a pitch of one thread per inch. The proportions of the linkage are such that about one and one-half revolutions of the hand wheel are required to turn the front wheels from one extreme to the other.

Figs 22 and 24 show respectively clutch, release pedal and the forked lever for disengaging the clutch. The

latter has a pair of small rollers on the forked ends, which engage the grooved collar on the clutch shaft for drawing the cones apart. Fig. 28 shows the brake pedal. This, as well as the clutch pedal, should preferably be a steel forging. Fig. 20 shows the brake shoe, which may be a casting of alzinc and is faced with leather for friction surface. This may be secured to the metal surface of the shoe by means of shellac and a considerable number of wooden shoe pegs. The wear on this facing will probably be rapid but it can be easily and cheaply renewed.

TOOL MAKING FOR AMATEURS.

ROBERT GIBSON GRISWOLD.

III. Special Tool Steels.

In this chapter we touch for the first time the domain of special tool steels. The small hand tools treated in the first two chapters were all made of what is commonly known as ordinary tool steel, which is technically termed a "high carbon steel" and can be hardened in water or oil.

Lathe tools, however, are usually made of a special self-hardening steel that will not bear water, but must be hardened in a current of air. The reason for this is that they are in general harder than a carbon steel and hold their edges better; in fact, some of them will hold their edge while red hot under the chip. It is this quality which makes the new high-speed steels so valuable. With them the cutting speeds are materially increased, which lessens the cost of production.

These steels are made by what is known as the *Crucible* method. For those unfamiliar with the process a short description will be given. It may be well to add that the structural steels are made by what is known as either the *Open Hearth* or the *Bessemer* process. In the former the steel is melted in a large furnace and poured from there into large ingot moulds. In the Bessemer method the steel, after melting in a furnace, is poured into a huge barrel-shaped receptacle through which a current of air is forced. In this receptacle, called the converter, the chemical changes take place, after which the molten metal is poured into molds as above. These are the two methods mostly in use today for producing steel in large quantities. The product might generally be termed a mild steel.

But the crucible steels are much more costly, owing to the greater cost of production. In the crucible process the materials used to make the steel are either bar iron, puddled iron or blister steel. The crucibles in which the steel is melted are made of clay or graphite, holding anywhere from 50 to 100 lbs. These crucibles are charged cold. The pieces of iron are placed in the crucible and thoroughly packed with

charcoal, mixed with a little manganese, and occasionally a little ferricyanide of potassium or common salt is mixed with it. The crucible is then covered and placed on the coals in a hot furnace.

After a period of three hours the cover is lifted, the charge having melted by that time and the melter determines upon examining the condition of the charge, the duration of the "killing" period, generally about 45 minutes. During this period the metal is becoming tranquil and is absorbing silicon from the walls of the crucible, the latter element preventing blow holes. At the proper time, determined by the experience of the melter, the crucible is removed from the furnace and the molten charge skimmed of its slag, after which the metal is cast or "teemed" by pouring into split ingot molds.

These ingots are graded and converted into bars of various sizes. Owing to the fact that pure materials are used in making up the charge, and that it is protected from the sulphurous gases from the fuel, this crucible steel furnishes the finest grades for cutlery and machine tools. The Bessemer and open hearth steels are very much inferior to crucible steel, the latter having a low percentage of phosphorous, low sulphur, no iron oxide, less gases, high silicon and high carbon.

The crucible steels are graded about as follows, the grades becoming better towards the bottom of the list:

Die. Contains about .75 percent carbon, has little temper, is difficult to burn and welds easily.

Set. Contains about .875 per cent carbon, has little temper, easily welded and burns with difficulty.

Chisel. Contains about 1.00 percent carbon, has a fair temper and is not readily burned.

Spindle. Contains about 1.125 per cent. carbon, welds with difficulty, has hard temper and not very readily burned.

Saw-file. Contains about 1.375 per cent carbon, hard

temper and welds with some difficulty.

Razor. Contains about 1.5 per cent carbon, is very easily burned, has very hard temper and welds with extreme difficulty.

The effect of different elements on steel will be of interest at this place:

Carbon. Up to 1.5 per cent increases tensile strength and raises the elastic limit; the welding power and malleability are decreased.

Silicon. Increased hardness, tensile strength and compression strength, homogeneity and prevents blow-holes, but too much makes steel brittle. From 3 to 5 per cent should be about the range.

Sulphur causes hot shortness, that is, the metal is brittle when hot, both under the hammer and rolls.

Arsenic. Same effect as sulphur.

Phosphorous. Causes cold shortness. It makes steel hard and liable to break, but increases the elastic limit and reduces elongation.

Manganese. Prevents hot shortness and blow holes, removes or offsets the effect of sulphur; elongation, toughness and tensile strength are increased by its presence, but too much renders the steel brittle when cold, especially after quenching.

Copper. Causes red shortness.

Tin. Renders steel not forgable or ductile either while hot or cold.

Tungsten. Renders steel very hard.

While tempering was spoken of in the first article, it will be well to speak of the process of hardening and tempering more fully at this place. The combined processes of hardening and tempering steel give to it the necessary hardness combined with the requisite toughness. It takes more than mere hardness of cutting edge to make a good tool. A tool may be so hard that it will readily scratch glass and yet be totally unfit for turning even soft metals like lead and copper. This is due to the fact that the process of hardening renders the steel very brittle, while the subsequent process of tempering reduces, or grades, the degree of hardness and at the same time imparts to the steel a certain degree of toughness, which property enables the tool to hold the hardened edge without cracking off readily.

The tool, after forging to shape, is hardened by heating to a cherry red and plunging it into a bath of water, brine or oil, for a short distance above the cutting edge. The tool should be moved about in the cooling medium to prevent the clinging of steam or vapor bubbles, which would cause soft spots. The portion of the tool above the surface of the bath will remain at a dull red heat for some little time.

The hardened end is now quickly polished on a smooth surface by rubbing it with a strip of emery cloth glued to a flat stick. The heat in the stock of the tool will now begin to creep into the quenched hardened portion by conduction and increase its temperature. As this temperature increases, the oxides will begin to cover the polished surface in distinct bands or waves, advancing in a regular procession as given in the table of tempering colors in first chapter,

pale yellow, straw yellow, brown yellow, light purple to a dark purple, and finally a blue. As the desired color reaches the cutting edge, the tool is suddenly plunged beneath the water or oil and constantly kept in motion. This fixes in the steel the definite degree of hardness determined by the color, and the process has rendered the steel tough enough to stand up to its work. The entire process requires practice and thoughtfulness more than anything else to render one proficient. There are many tools that will not stand such treatment. The above, of course, applies only to carbon steels. The self-hardening steels should never touch water while hot. They are peculiarly air-hardening steels.

One of the oldest and best carbon steels is the Jessop's steel. It hardens at a low red heat. In forging do so at a full red heat, but be very careful not to over-heat, and avoid a strong blast. Heat uniformly, allowing time for the heat to reach the centre, and turn the tool in the fire so that one side will not be heated more than another. The fire should be of good size and free from sulphur. Do not try to forge steel at a dull heat. This should be used only at the finish. Stubb's steel is probably well known in the form of drill rods. Its treatment is the same as that for carbon steels.

Under the head of self-hardening steels come the Musher, Jessop's Self-Hardening, Novo, Sanderson's, H. S. H. and C. L. makes. The Taylor-White process and Special steels require special treatment, the method being secret and sold only on shop rights.

In the case of the self-hardening steels, they are forged at a full red heat. To harden they are generally heated to a bright heat and set in a cool, dry place. They are never subjected to the action of water. The Jessop's self-hardening steel is heated to a white heat for hardening, as it cannot be burned. As a matter of fact, each special steel is generally accompanied by a label or card, giving directions for working and treating.

In the case of special formed cutter, large dies and taps and large hollow mills, the heating for tempering is generally done in hollow rings or between hot plates or some such method, to insure even, regular heat.

Large tools should be ground on a wet wheel to prevent the heat drawing the temper. Especially is this true with lathe tools. Use as fine a wheel as possible for finishing the edge, which should be smooth and keen.

In the newly invented apparatus for milking cows by electricity rubber hoods are attached to the udder of the cow. These hoods are connected with a vessel for receiving the milk by means of a rubber tube from which the air is exhausted by means of the electrical device. It is claimed that the cow "lets down" her milk more freely than when milked by hand. It is also claimed that absolute cleanliness of the milk may be secured when this method of milking is employed.

TWIST DRILLS; THEIR USES AND ABUSES.

By Courtesy of the Cleveland Twist Drill Company.

The advent of the now common twist drill marked a very important period in mechanical industry. It is, all things considered, the most efficient tool used by mechanics, as in no other tool is the cutting surface so large in proportion to the cross sectional area of the body or part which is its real support.

By actual measurement of the cross section of the fluted part only 50 per cent is left for effective work, yet it will bear more stress in proportion to its own strength than any tool, for the reason that it is supported by the metal upon which it is operating, and is thus prevented from springing away from its duty. This support may be of two kinds; first that due to the wedge-like action of the point, and the second that derived from the small amount of concentricity which the drill has just behind the cutting edges, see Fig. 1.

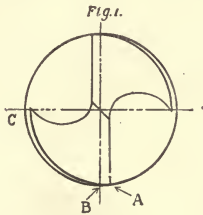

The latter, however, is of little importance, as in a large number of cases only one side of the drill gives any support to the cutting edges, as will be seen in paragraph under grinding of points.

The support given the drill in the instance first cited is of more importance and arises from the tendency of either cutting edge to spring away from the cut, which in a correctly ground drill is, of course, counterbalanced by the opposite cutting edge having the same tendency, only in an opposite direction, so that with the feed pressure on the drill tending to force the cone shaped point into a cone shaped hole, the drill is held rigidly in a central position.

A twist drill is a tool generally formed by milling or forging two equal and opposite spiral grooves upon a cylindrical piece of tool steel of such shape as to make a suitable cutting edge on its cone shaped end.

Drills are not of the same diameter from end to end of the twist, but decrease in diameter from the point towards the shank by an amount varying from .00025 to .0015 per inch in length, according to the size or particular use for which they are intended. This gives a longitudinal relief to the drill which is very essential in accurate drilling.

Neither are they exactly round, as their diameter is eased away from a short distance behind the cutting

edge back to the flute, as in Fig. 1. The distance between A and B is of full diameter and round, while from B to C it is eccentric or, more strictly, is a surface whose cross section is a spiral with its centre in the centre of the drill. This is called *body clearance*. The object of this is to give radial clearance to the drill and thereby reduce the friction between the drill and the walls of the hole. Without this body clearance more power would be required to turn it and in some cases enough heat would be generated to draw the temper in the drill to a degree which would unfit it for further use.

To give the drills as much strength as possible the flutes decrease in depth toward the shank, that is the "web" between them gradually increases in thickness toward the shank; this is accomplished by gradually withdrawing the milling cutters as they approach the shank, and is called web increase.

This operation alone would seriously impair the

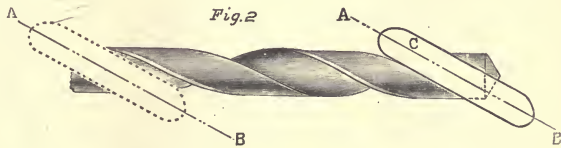

chip room in the tool, and to avoid this defect the spiral is increased in pitch by an amount that, combined with the web increase, will preserve the correct and equal cross sectional area of the flute from point to shank.

This is made plain by reference to Fig. 2 in which the cutter C is in position at the point of the drill with its path on line AB. As the blank is fed uniformly forward it revolves at a rate which is constantly diminishing, and as the axis of the cutter remains in a fixed angular relation to the axis of the drill, it is obvious that the flute will be wider at the shank end than at the point, and at the completion of the groove the cutter will be in position shown by dotted lines; but as the cutter is gradually withdrawn in depth the combination of these two movements retains the proper volume of the flute for free egress of chips.

With a special apparatus for making an autographic record or diagram of both the feed pressure and the torsional stress when forcing a drill through a piece of metal, we performed experiments which showed the most efficient form of point, manner of grinding, etc.

We replaced the usual swing table of a drill press by a special hydraulic one arranged so that the exact feed pressure and torsional stress was measured and recorded by two Bristol Pressure Gages, the clock

mechanisms of which were removed and a spring drum substituted by which the vertical movements of the drill spindle revolved the charts.

The charts shown are from a $1\frac{1}{2}$ in. drill, running 66 revolutions a minute with a feed of .0075 in cast iron, machinery steel and annealed tool steel. The concentric circle on feed pressure chart between lines reading 10 and 20 represents the weight of table and "billet" drilled into. The lines marked 1 are cast iron and show quite a uniform curve, while the lines marked 2 and 3 are respectively machinery steel and tool steel, and show more irregularity in the curves.

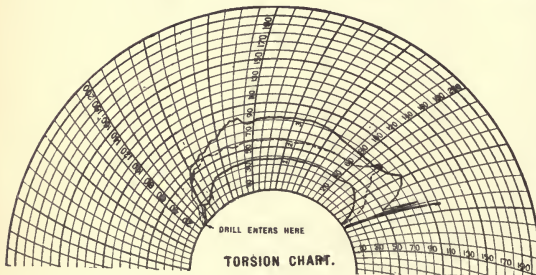
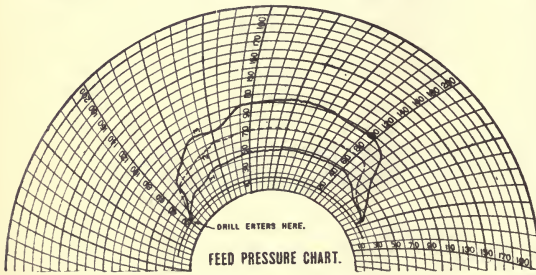
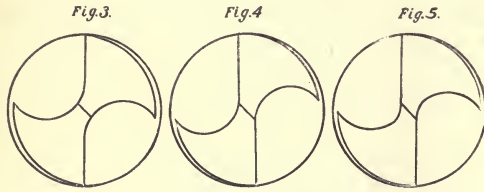

The general contours of the feed pressure curves for tool steel are very much alike, showing a steady rise until the lips are cutting nearly full size, then dropping slightly, due to the spiral helping to pull the drill in, then rising again steadily to a point about a third through the billet, due no doubt to the billet not being annealed uniformly clear through.

The feed pressure diagrams fall off very rapidly as the point begins to come through, while the tension diagrams for steel rise very abruptly; and the tool steel one (the piece not being clamped down) shows

plainly where the lips caught and raised the piece, giving several very quick jerks, a result which is experienced very often when holding a piece by hand to drill it.

These points indicate where the outer parts of the lips are generally broken, especially where lever feeds are used, or the spring between the parts taking thrust is considerable. This feature is very common in the drilling of the rivet holes in cylindrical shells where the inside curvature greatly augments the tendency of the drill to "hog in."

The feed in this test was purposely kept down to



FIG. 6.



FIG. 7.

what may be termed fair practice in order to have the same grinding answer for all three holes. The difference between the curved lines pointing toward the centre represents a distance of .05 inch in depth drilled on both charts. To find the actual feed pressure in pounds multiply the indicated pressure on chart by 20. To find the torsional stress in pounds at the periphery of the drill, multiply the indicated pressure on the chart by 20 and divide by the diameter of the drill.

We found the shape of groove, the angle of point, the angle of spiral and the manner of grinding all affected the power needed to drill a given hole. The thickness of web also affected the result, but this is probably the most uniform feature on the different makes of drills, and varies but slightly.

A groove formed like Fig. 2 required the most power, while those like Figs. 4 and 5 gave the best results. A little study of Fig. 3 will show that the cutting edges are very poorly formed, especially toward the cutter where there is very little of the shape which will allow free curl to the chips. Fig. 4 represents a very free cutting drill; the shape of the groove is such that the chip curls up to the full size of the groove and very little power is consumed in feeding it. The form of the chip is very similar to an open string wound with ribbon steel, and somewhat resembles a cylinder in appearance, see Fig. 6. Fig 5 represents a form of point very desirable for several reasons and is the shape which we have adopted. It does not require any morepower (in fact slightly less) than the point like Fig 4, and rolls a beautiful chip (see Fig. 7) of which each turn is slightly conical in shape, slightly less in diameter than that of Fig. 6, but they lie one within another so that the length of clip in drilling a

hole one inch deep is not a quarter as long as that made by a point like Fig. 4 drilling the same depth. Our tests with different angles of points showed that the feed pressure varied almost directly with the num-

ber of degrees in the included angle of the point between 110° and 136°. Different materials gave somewhat different results, the variation being not so great in the harder materials.

JUNIOR DEPARTMENT

For the Instruction and Information of Younger Readers.

ELEMENTARY MECHANICS.

J. A. COOLIDGE.

IX. Specific Gravity.

We saw in our last chapter that every solid substance, when floating or immersed in a liquid, lost part or all of its weight, and that in bodies capable of floating, the shapes could be made such that additional weights could be carried. In this paper it is our purpose to study the buoyant effect of liquids on bodies that will sink, and to see whether this knowledge will

whole cylinder in melted paraffine so that it shall not absorb water. Weigh it carefully, and with a pair of calipers get its diameter as accurately as possible. The volume of the cylinder, radius x radius x 3 1-7 x length we must next find. It should be needless to say that the radius is one-half of the diameter and that the volume is equal to the base, radius x radius x 3 1-7, multiplied by the length. Next hang the cylinder by a thread and weigh it immersed in a jar of water. See Fig. 27. The buoyancy of the water is found by subtracting the weight in water from the weight in air. The weight of an equal volume of water is found by multiplying the volume expressed in cubic inches by .58. This will give the number of ounces of water displaced by the cylinder. When we compare this with the loss of weight just found we see that they are the same, and if the experiment should be performed with some other liquid than water, the same principle will be found true; that is, that the amount of loss of a body in any liquid is equal to the weight of the displaced liquid. The discovery of this made Archimedes famous in history and the word, eureka, well known to all. The story of King Hiero and the crown that he feared was not true gold, and how Archimedes proved that the king had been deceived, is a tale of interest to old and young.

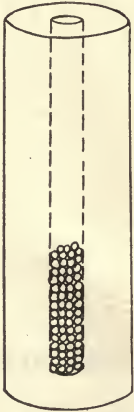

FIG. 26.

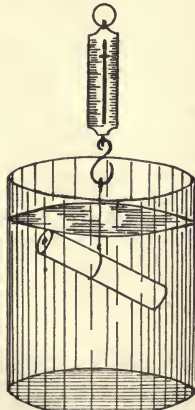

FIG. 27.

EXPERIMENT XXIV.

Having studied this principle we are now prepared to examine a number of different substances and to compare them. Get a piece of coal, of glass, marble, lead, iron, zinc and, if possible, aluminum; weigh these in air and then in water, hanging them by a thread, as you did the cylinder in Fig. 27. The loss of each in water is equal to the weight of the displaced water. Is it not a simple matter to compare each with the weight of the same volume of water and then with another substance? For instance, our marble weighs 8.1 ounces in air and 5.1 ounces in water. The loss is 3 ounces, therefore three ounces is the weight of a body of water equal in volume to the marble. The ratio of the marble, 8.1, to the water, 3, gives us 2.7. We know that marble is 2.7 times as heavy as water. This ratio of a substance to the equal volume of water is called the specific gravity of that substance. Let us find the specific gravity of coal, glass, lead, iron, zinc, aluminum and others, and arrange as in the table below:

be of any practical value. In beginning we wish to find the exact relation between the buoyancy of the liquid and the substance immersed in it.

EXPERIMENT XXIII.

A cylindrical piece of curtain pole, 4 in. long and 2 in. in diameter, with a hole 1/4 in. diameter bored in the centre of one end to within 1/4 inch of the other, will serve our purpose. Put enough lead shot or scraps of lead in this hole to make the cylinder sink in water, fit a wooden plug in the open end and soak the

Substance	Wt. in air.	Wt. in water.	Loss.	Sp. Gr.
Marble	8.1	5.1	3	2.7
Coal				
Lead				

Of all the substances we have seen, gold is the heaviest, having a specific gravity of over 19. Lead is heavier than iron, and aluminum is the lightest of all the metals. Many metals are seldom used in a pure state but are mixed with some other metal (or alloy) to make them harder, stronger, more brittle or more elastic. Gold coins are not of pure gold but are mixed with copper to make them harder. The statement that gold is 18 k, means that 18 parts are gold and 6 parts copper. It can be seen that one might tell the purity of a metal if one knew its specific gravity.

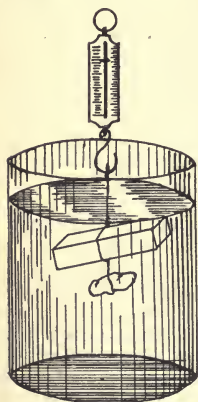

FIG. 28.

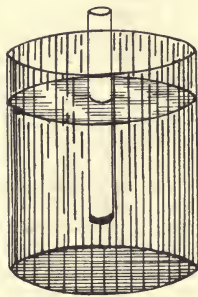

FIG. 29.

The finding of the specific gravity of woods and other bodies that float gives a little more trouble, as the shapes are often irregular, and as the body floats we must adopt some other means of finding the weight of the displaced liquid.

EXPERIMENT XXV.

Given an irregular piece of wood; find the specific gravity. Weigh it first and call its weight W . Take a piece of stone and weigh that in air, calling the result S , and in water, calling the result S' . Find the loss of the sinker. $S-S'$. Tie the stone to the piece of wood and weigh both in water, as seen in Fig. 28. From the sum of their weights in air take the weight of both tied together in water, and we have the loss of both. From this subtract the loss of the sinker, $S-S'$, and we have the loss of the wood. The weight of the wood divided by this loss will be the specific gravity of wood. This varies much for different woods, being as low as .11 for porous cork, up to .8 and .9 for heavy oak woods and others.

We must now find the specific gravity of liquids. Of the tests made for milk, vinegar, etc., the specific gravity forms a part. There are several ways of finding

this, but we shall speak of two only. A small bottle with a tightly fitting glass stopple with the exact amount of water it contains marked upon it, and with a brass weight that just balances the empty bottle can be bought. This is filled with a liquid and the weight of the liquid alone obtained at once. This weight divided by the figure on the bottle will give the specific gravity of the liquid.

EXPERIMENT XXVI.

Take a small bottle with a tightly fitting glass stopple and find its weight, B . Fill with water and weigh again, calling this T . $T-B$ gives the weight of the water. Fill the bottle with another liquid and call this L . $L-B$ is the weight of the liquid in the bottle. Divide L by $T-B$ and the quotient will be the specific gravity of that liquid.

EXPERIMENT XXVII.

Take a cylindrical wooden rod $\frac{1}{4}$ in. in diameter, flatten a lead bullet, or make a thick washer of lead and fasten to one end so that when placed in water it will float erect, as in Fig. 29. A very small elastic band, or thread, around it may be made to serve as a marker. It should be covered with wax to prevent soaking in water. Place it in water, mark the depth it sinks, and call this Dw . Do the same in some other liquid, such as vinegar, oil, or a solution of blue vitriol. Call this depth Dl . As a floating body displaces its own weight, the depths Dw and Dl give amounts of water and the liquid that have the same weight. Suppose those figures were 7.2 in. in water, and 5.4 in. in the liquid; then 5.4 in. of this liquid equals 7.2 in. in water, and this liquid is as many times as heavy as water as 5.4 is contained in 7.2, or 1.33. We see that this liquid is 1.33 times as heavy as water. This wooden cylinder might be called a hydrometer, but those in actual use are made of a glass tube with a bulb at the bottom and a scale on the tube. The distance it sinks in water is usually marked 100 on the scale and this is divided by the distance it sinks in other liquids. Many hydrometers are made to suit the needs of special operators and their uses are very simple.

A LETTER TO YOUNG MEN.

MICHAEL DAWES.

"Wanted. Good, bright, intelligent American boys between sixteen and eighteen years old to learn the machinists trade; must have had a grammar school education or its equivalent. Apply to, etc."

MR. EDITOR:—This is the way I would advertise were I in need of boys to learn the machinist's trade. Perhaps I can give you a better idea of what I wish to say by stating some of the difficulties frequently experienced by manufacturing establishments in their efforts to obtain the right kind of boys, and if these few cold facts are brought to the attention of the fath-

ers through such a medium as I find AMATEUR WORK to be, it may be of advantage to some boy who hopes to better his condition. In parenthesis let me say that if the fathers only knew what wholesome, fascinating and interesting subjects, for both boys and men of a mechanical turn of mind, could be found within its covers, they would invest a dollar with you for a year's subscription. The result would be to encourage them to do something for themselves. I could continue writing commendatory things about your magazine, but the more I might write the further away I would be from what I started out to do, and that is to state how hard it is to get the right kinds of boys for trades; boys that will eventually develop into good men, masters of their chosen trade and capable of taking the positions of foremen, etc.

The man in charge of the apprentices is notified that an applicant is waiting. He finds a mother or a father with the son, and soon getting right down to business the questioning begins. The terms and conditions under which boys are taken having first been stated, "Why do you want to become a machinist?" "Have you ever worked anywhere?" "At what?" A glance at the boy's hands discloses that the fingers and thumbs are brown or yellow on the tips. "Do you smoke cigarettes?" An affirmative reply is given, the only answer that could honestly be made. This applicant is then told that, no matter how well qualified he was educationally, or how excellent his references might be, he would *not* be accepted, the interview ends, the disappointed parents leave, casting reproaches on the boy. "There, Johnnie! I wanted you to stop cigarette smoking, and that was the first thing the man inquired about." Too often the case.

Perhaps the next boy who applies does not use tobacco or liquors. He, also, is accompanied by a hopeful parent and has a school pin conspicuously displayed on his coat or vest. Yes, he graduated from the grammar school or went to the eighth grade. "Do you understand fractions, decimals and proportion?" "Yes, sir." And yet the boy is rejected. Why? Simply because, on examination, it is found that he cannot find the sum of a fraction and a decimal, nor can he convert a fraction into a decimal or *vice versa*.

Note that nothing is asked is as to his knowledge of grammar, geography or history; just a few simple questions in arithmetic. If the boy appears to be embarrassed he is given questions leading up to what is required, or he is left entirely by himself with paper, pencil and questions, and when he has had ample time in which to answer the questions he is again interrogated. Yet he fails, and what is his excuse? "I knew it at school." I say, "No, he did not." To illustrate: Ask that boy what is the sum of two and two; with hesitation he gives the correct answer. "Then you learned that at school?" "Yes, sir." Showing conclusively that what was learned was remembered. And this condition is found too frequently. Good, bright appearing boys apply and are rejected because they do not possess a thorough knowl-

edge of common school arithmetic.

If the parents and the boy could only be impressed with the importance of this matter, the boy would not seek an opportunity to learn a trade without preparation, and I use the term generally now, as such knowledge is as necessary and applies as forcibly to the pattern maker's or the moulder's trade as it does to the machinists. Boys of sixteen, seventeen and eighteen years of age, and yet unable to solve simple problems from a common school arithmetic! Do they think a manufacturer has time to teach them arithmetic? If so they are greatly mistaken. If we are going to turn out young men who, after completing their apprenticeship are able to do the better grades of work as well as being capable of directing the work of others, we must insist upon their having a reasonable amount of education to begin with. The manufacturer of today has but little use for a boy of easy morals; it is the upright, manly, clean boy he is looking for. The positions now filled by the heads of different departments will eventually be filled by the capable and intelligent boys of today. The boy who frequents dance halls, billiard saloons, low theatres, or is addicted to the cigarette habit, need never expect to be chosen for any position of trust. We do not care to have him around.

He is not the boy wanted.

JOINTS IN WOODWORKING.

FRANCIS L. BAIN.

III. Mortise and Tenon and Dowelled Joints.

The style of joint to be used in door, sash and blind work and other work of a similar nature depends largely upon two factors, namely: thickness of material to be used, and purpose for which the completed work is to be used. For instance, if the stiles and rails of a heavy door were $1\frac{1}{2}$ in. thick the use of dowels as the only means of joining would not be practical, as the unusually heavy strain and the constant moving of the door would eventually dislodge or weaken the dowels. On the other hand, if the frame for the door of a bookcase or wardrobe is being made, maple dowels are usually amply sufficient if properly glued in place, as the stock is so much thinner and lighter, thus relieving a great deal of the strain previously referred to.

In connection with the purposes for which the completed work is to be used, a good argument in favor of mortise and tenon joints can be derived from the consideration of a window frame with the constant jars and moving which many of them have. In this case the dowels would almost certainly become dislodged by the vibration, while the mortise and tenons would weaken very little, if at all. Dowels are, however, very commonly used in connection with this joint, being driven right through it from one side of the stock

From many true and tried suggestions concerning the two varieties of joints above referred to the following have been chosen as the most practicable and valuable:

Referring to Fig. 1. The distance *a* should never be less than the thickness of the stock *b*, as a lesser distance would weaken the stock at that point and perhaps cause a breaking out of the dowel later, or at least a fraction of the stock near the dowel.

A dowel should be inserted into each of the pieces it joins at a distance equal to at least twice its diameter, whenever possible.

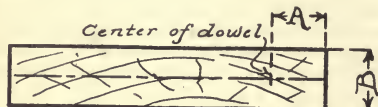

Fig. 1

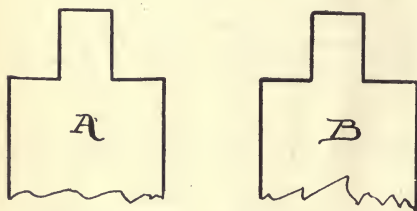

Fig. 2

The thickness of the tenon in a mortise and tenon joint should usually be one-third that of the stock from which it is formed, as the mortise should, of course, be a corresponding width. The shoulders of the tenon, properly made, should be exactly square across as shown at B, Fig. 2, but many amateurs find "chiselling to a line" rather irksome, and for the benefit of such a very slight concave is allowable, as shown at A, Fig. 2.

Unless joints are intentionally made to be taken apart, as in the case of halves of patterns, they should be thoroughly glued, as this adds 60 per cent. to the strength of the joint. Mortises and tenons should also be carefully glued, unless there is some reason for putting together without the gluing.

The next chapter will deal with the halved and dovetail halved joints.

It has been demonstrated that ground ivy and mustard can be destroyed through sprinkling with a solution of copperas (sulphate of iron), and that cereals are not injured by it.

ELECTRIC ALARM FOR CLOCK.

E. A. WHITE.

It will undoubtedly interest some of the readers of this magazine to know how to arrange an alarm clock so that it will close an electric circuit at the time at which the alarm is set to ring, and by this means sounding an electric bell in place of the alarm on the clock. A piece of pure copper wire of No. 14 or 16 gauge, about 4 in. long, and a piece of adhesive tape about 2 in. long are required, as well as a dry battery and common electric bell. Unscrew the ring *i* from the top of the clock and remove the gong, then replace the ring. Wind the piece of copper wire *g* two or three turns around the post, after covering the latter with adhesive tape, and twist the ends together so as to hold the wire and tape securely. Bend one or the free ends into a hook, to which attach a wire from the battery, and bend the other free end in the opposite direction so that it will engage the hammer that strikes the gong when the hammer moves.

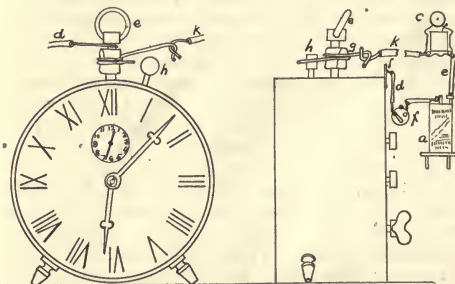

If the clock is to stand on a shelf, connection is made from the switch *f* to the clock itself by placing the clock on a piece of sheet tin or brass to which the wire *d* is fastened, or by fastening this wire to the ring *i* at the top of the clock.

Put the battery and bell in a convenient place, and if the arrangement is to wake one up in the morning the switch *f* should be placed on the wall within reach of the bed. The writer has a nail driven in the wall near the bed on which the clock is hung by the small ring on the upper part of the back *b* and around which the wire *d* is wound. This makes contact with the clock itself, and when the clock is to be wound up it is only necessary to unhook the wire *e* and take the clock off the nail *j*. The switch *f* is placed beside the clock. The writer also has a switch placed on the wall beside to the other, a process which practically insures a double amount of strength at the joint.

the switch *f* so that by reaching out of bed and turning the switch the electric light in the room is turned on. The face of the clock can then be seen, being so near the bed.

The connections are as follows: One pole of the battery *a* is connected by the wire *b* with the bell *c* and another wire *k* connects the bell with the switch *f*; the end of the wire *d* from this switch is then made in the shape of a hook and can be easily hooked and unhooked to the wire *g* on the clock. The other pole of the battery *a* is connected to the ring *i* on the top of the clock, to the nail *f* on the wall or to the piece of tin on the shelf, according to the method followed in making connection with the metal part of the clock.

We will now suppose that it is desired to ring the bell at six o'clock. The alarm and time springs of the clock are wound up, the alarm hand set at the figure 6 and the switch *f* closed. When it is six o'clock the trigger, or hammer *h*, on the clock will spring forward and stay against the wire *g*, held by the alarm spring of the clock. This makes contact from the metal part of the clock to the wire *g* through the hammer *h*.

The circuit is thus completed and the bell will ring until the switch *f* is opened. To set the clock to ring again the hammer *h* is pulled back (it will not stay until about half an hour after the alarm has gone off) out of contact with the wire *g* and the switch *f* closed. Other apparatus instead of the bell may be operated at a certain time by means of the clock, by substituting that apparatus in place of the bell. The writer has used this arrangement for a long time to ring a bell and awaken him in the morning.

CORRESPONDENCE.

No. 84.

CHICAGO, ILL., Sept., 1904.

In several published description of receiving instruments for wireless outfits, one side of the coherer goes to the aerial wire and the other side to the earth. One side of the sensitive relay goes to the hammer of the decoherer, which also connects by contact point to the ground side of the coherer. When the relay operates, the heavy battery works the sounder and at the same time the same battery shunts through the windings of the decoherer and operates that simultaneously. Now, in view of these conditions, I do not see how one can get anything else than "dots", for just as soon as the decoherer operates the relay opens and the sounder stops, and just as soon as the relay operates the decoherer works simultaneously with the sounder. Please tell me how such a system gives dots and dashes. I enclose sketch.

J. R. B.

The circuit described is similar to several systems, among which is the Slaby-Aroo, which is quite popular on both continents. The decoherer is a high-frequency hammer, as speedy as the quickest small vibrating bell mechanism. The stroke is adjustable.

The magnets of the Morse sounder and the decoherer are connected in parallel and are wound to the same resistance.

The decoherer gives a sharp blow against the coherer, and the weak relay-coherer battery circuit is broken just before the blow is made upon the coherer.

When the resistance of the coherer filings is broken down the weak battery is permitted to operate the relay, which in turn closes a local and stronger battery through the sounder and decoherer at the same time. When this is done the decoherer armature is drawn down, but in so doing the weak relay battery is opened off of the decoherer hammer, the relay flies back, and the decoherer and sounder, because of the break in circuit at the relay contact, return to their normal position, and it is this upward stroke of the decoherer which restores the coherer to its high resistance. The electrical energy radiating from the sending aerial in the form of etheral waves is collected on the receiving wire in the form of an alternating potential and conveyed to the coherer. When this tension affects the coherer, the relay operates as described. The sounder and decoherer armatures start at the same time, and if the wave represents only a dot the sounder armature returns shortly after the decoherer acts. But while the decoherer is quick, the armature of the sounder is rendered sluggish by mechanical adjustments, which can be readily varied to suit, and when the series or train of interruptions representing a dash is being received the decoherer performs its function and springs back and forth many times before the sluggish armature of the sounder can rise. This feature presents itself most clearly in the operation of any inking device used in connection with the recording instruments."

TRADE NOTES.

DRILL WITH ADJUSTABLE TENSION.

Of all the automatic hand drills in the market up to the present time there has never been one that has been entirely satisfactory for general use. The trouble has been that no one strength of spring in these tools would be satisfactory in both soft and hard woods, or for the large and small drills furnished with the tool. The best that could be done was to use a spring of average strength.



In the new drill, No. 44, manufactured by North Bros. M'fg. Co. Philadelphia, Pa., this difficulty has been overcome by a device to adjust the tension of the spring, making it weaker or stronger. The spring is

held at desired tension by a small bolt or lock which engages in the cap and is operated by a small knob on side of handle.

To adjust the spring pull down the bolt on side of handle, turn the cap on end of handle to the right for heavier tension for hard wood or larger drills, or to the left for soft woods or smaller drills. Turn cap, to hold it from turning while using the tool.

To open magazine in handle containing the drill points, hold the drill with the chuck end up, and unscrew nut above handle, and all the drill points will be in sight, thus enabling the user to quickly select and remove drill point required. To insert the drill points, hold the drill with chuck end up, turning sleeve on same to right as far as it will go. Insert drill point so that it catches at the bottom of chuck and will not turn, then turn sleeve to left until drill point is held solid.

The tool is nickel plated and finely finished, the materials and workmanship throughout being of the best.

Built to work 8, 12, 16, 24 and 30 in. wide, the adjustments, solidity and advantages of construction of this planer enable a wide range of work to be done upon it, such as squaring, smoothing, taking out of wind, glue jointing, bevelling, chamfering, rabbeting, moulding, tenoning, etc. It will also stick curved mouldings, such as casing heads, special inside finish mouldings, etc., which have heretofore been done by hand.

There are no links, wedges, pin joints or eccentrics under the table to get out of adjustment or wear slack; by putting the frame on three legs it is impossible to strain or twist it by bolting down or by the settling of the floor. By means of the large hand wheel at the right the working table can be moved instantly either way without requiring the operator to change his position in the least. The design and method of fitting up is such that the tables must be true and remain so, and they cannot twist, rock, strain or be displaced, no matter how uneven the foundations on which they are placed.

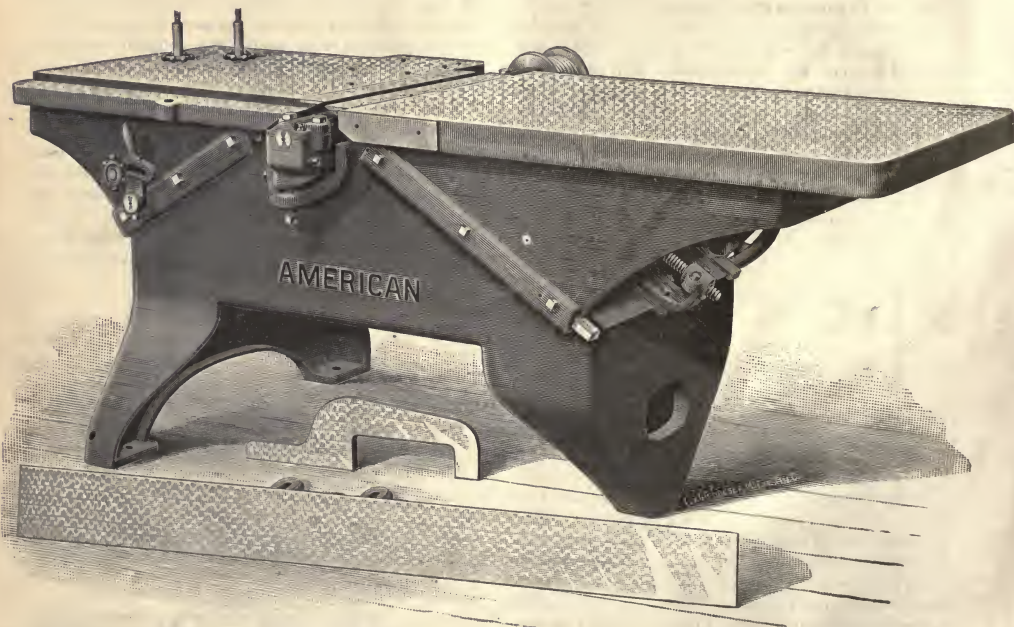

JOINTERS AND BUZZ PLANERS.

The accompanying cut illustrates the latest improved new pattern machine, manufactured by the American Woodworking Machinery Co. It has been made heavier and stronger, and with the improvements is the best machines of its class on the market.

The several salesrooms of the company are as follows: 136 Liberty Street, New York City; 43-45 So. Canal Street, Chicago, Ill.; Hennen Building, New Orleans, La., and 145 Oliver Street, Boston, Mass.

The new motors and dynamos of Kendrick & Davis, Lebanon, N. H., are fine machines.





